

Canon

Laser Beam Printer

Satera

LBP 5900SE/5600SE

User's Guide



Contents

Turning the Printer ON/OFF (For LBP5900SE)	3
Turning the Printer ON	3
Turning the Printer OFF	4
When Not Using a Hard Disk	5
When Using a Hard Disk (Only When a Hard Disk is Installed)	6
Turning the Printer ON/OFF (For LBP5600SE)	8
Turning the Printer ON	8
Turning the Printer OFF	9
Online and Offline (Only for LBP5900SE)	10
Placing the Printer Online	10
Placing the Printer Offline	11
Paper Requirements	12
Usable Paper.	12
Paper Size/Type for LBP5900SE	13
Paper Size/Type for LBP5600SE	15
Abbreviations of Paper Sizes	16
Printable Area	22
Unusable Paper.	24
Paper Capacity of Paper Source.	26
Paper Capacity of the Output Tray	26
Loading Paper in the Paper Cassette	28
When Loading Paper in Cassette 1	29
When Loading Standard Size Paper in Cassette 2, 3, or 4	39
When Loading Custom Size Paper (Non-Standard Size Paper) in Cassette 2, 3, or 4	50
Loading Paper in the Multi-purpose Tray	60
When Loading Paper (Other than Postcards and Envelopes).	60
When Loading Postcards (Only for LBP5900SE)	66
When Loading Envelopes	71
Paper Jams	77
Procedure for Clearing Paper Jams	78
Replacing the Toner Cartridges	96
When a Message Appears	96
Replacing the Toner Cartridges.	98
Resetting the Counter of Toner Cartridges	105
In Case of LBP5900SE	105
In Case of LBP5600SE	106

Replacing the Drum Cartridges	108
When a Message Appears.....	108
Replacing the Drum Cartridges	110
Replacing the Waste Toner Container	133
When a Message Appears.....	133
Replacing the Waste Toner Container	134
Canceling a Job (Only for LBP5900SE)	140
Deleting/Pausing/Resuming a Job (Only for LBP5600SE)	141
Confirming the Printer Features	143
In Case of LBP5900SE	143
In Case of LBP5600SE	145
Service Call Display	147
In Case of LBP5900SE	147
In Case of LBP5600SE	149
Message List (Only for LBP5900SE)	152

Turning the Printer ON/OFF (For LBP5900SE)

The power switch to turn the printer ON or OFF is located on the right side of the printer. Be sure to observe the following instructions in order to prevent unexpected problems.

Turning the Printer ON

In order to use this printer, you should press "I" of the power switch to turn the printer ON. After running a self-diagnostic test on the printer unit and optional accessories, the printer will be ready to print.



IMPORTANT

- Do not turn the power ON immediately after turning it OFF. If you want to turn the printer ON again after turning it OFF, wait at least 10 seconds after turning the printer OFF before turning it ON again.
- Be sure to set the paper cassette in the printer before you turn the power ON for the first time after you install the printer.



NOTE

When turning the printer ON for the first time after installing the hard disk, or when being malfunction in the hard disk, it takes approx. 60 seconds to be ready to print because of formatting after turning the printer ON.

1 Press "I" of the power switch on the printer.

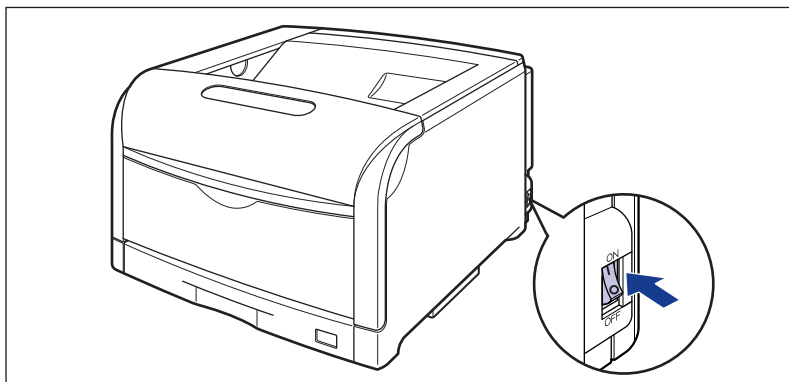

The indicators of the control panel and the display come on, and the printer initiates a self-diagnostic test on the printer unit and optional accessories.

If no abnormality is found during the self-diagnostic test, the オンライン indicator and the 印刷可 indicator, and the selected paper source display indicator comes on, <00 インサツ カノウ >, <00 LIPS>, or <00 ESC/P> comes on the display and the printer can be ready to print.

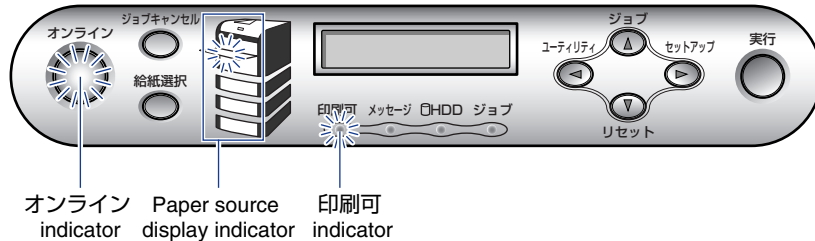

The following information is displayed on the display.

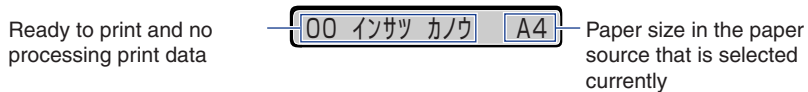

Turning the Printer OFF

Turn the printer OFF using the following procedure. The operation to turn the printer OFF is different in whether using the hard disk or not.

IMPORTANT

- When using the hard disk, be sure to turn the printer OFF as the procedure for the protection of the hard disk. (See p. 6)
- If the printer is used on a network, make sure that it is not printing data from another computer before turning the printer OFF.
- If turning the printer OFF with the ジョブ indicator being on, remaining print data will be deleted. Turn the printer OFF after necessary print data completing to be output or being output by selecting <ハイシュツ> with pressing [リセット] offline.
- Do not turn the printer OFF when the printer is in any of the following status:
 - During printing.
 - While the printer is running a self-diagnostic test immediately after turning the power ON
 - When the messages informing you that the NVRAM is being initialized or being written is displayed.
 - While <02 キドウチュウ> or <02 キャリブレーションチュウ> is displayed.
- When you are using a hard disk, make sure that HDD indicator is not on. If turn the printer OFF while the HDD indicator is on (while data is being read from the hard disk or being written to the hard disk), the hard disk may be damaged and disabled.

When Not Using a Hard Disk

When you are not using a hard disk, turn the printer OFF using the following procedure.

- 1** Make sure that ジョブ indicator is off.

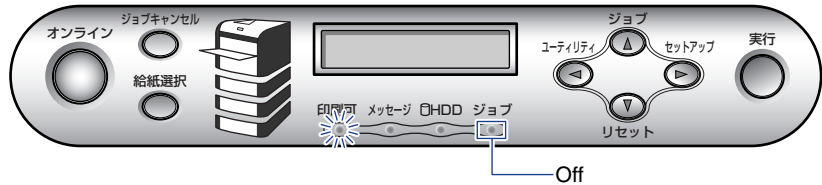

- 2** Press "○" of the power switch on the printer.

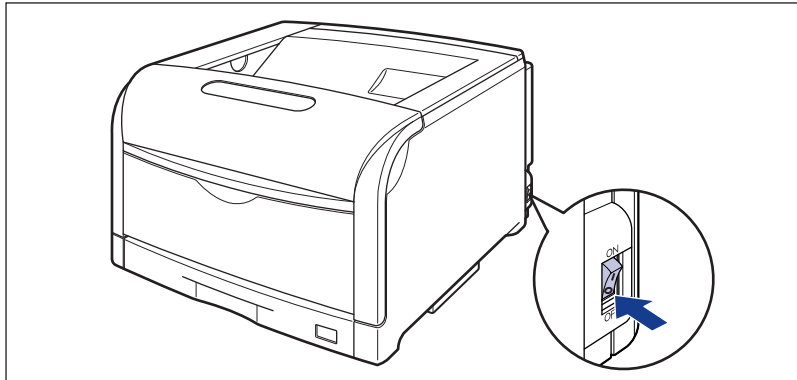

When Using a Hard Disk (Only When a Hard Disk is Installed)

When using the optional hard disk, turn the printer OFF using the following procedure.

IMPORTANT

- If you perform a shutdown when any job of which you stopped the operation or of secured print in the hard disk, the message <ジョブが ノコッテイマス> is displayed. If you perform a shutdown, all the jobs are deleted. However, the jobs saved in the boxes are saved in the hard disk as it is. When you want to continue to print, press [オンライン] to place the printer online.
- Once you perform a shutdown, you cannot cancel the operation in midstream. When you want to turn the printer ON again, turn the printer OFF once following the instruction of the message, and then turn the printer ON.

1 Make sure that the **ジョブ** indicator and HDD indicator are off.



2 Press [リセット].

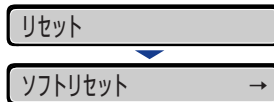

3 With [◀] and [▶], select < シャットダウン > and press [実行].





4 Confirm the message and press [実行].

シッコウ シマスカ?

シッコウ チュウ

デンゲンヲ オキリクダサイ

When the printer is ready to be turned OFF after the process for it is performed, the message <デンゲンヲ オキリクダサイ> appears.

5 When the message <デンゲンヲ オキリクダサイ> appears, press "○" of the power switch on the printer.

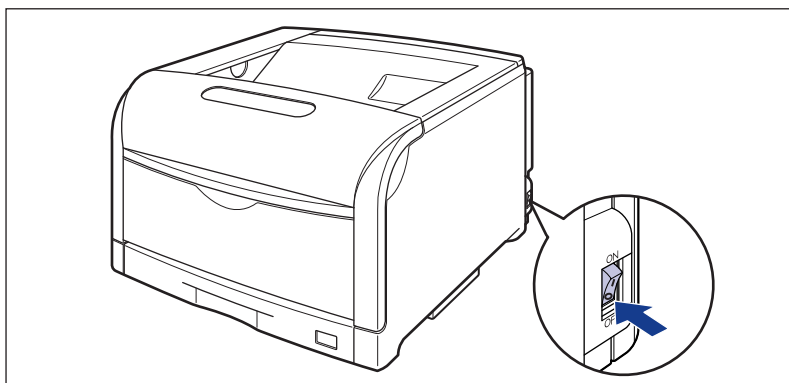

Turning the Printer ON/OFF (For LBP5600SE)

The power switch to turn the printer ON or OFF is located on the right side of the printer. Be sure to observe the following instructions in order to prevent unexpected problems.

Turning the Printer ON

In order to use this printer, you should press "I" of the power switch to turn the printer ON. After running a self-diagnostic test on the printer unit and optional accessories, the printer will be ready to print.

IMPORTANT

- Do not turn the power ON immediately after turning it OFF. If you want to turn the printer ON again after turning it OFF, wait at least 10 seconds after turning the printer OFF before turning it ON again.
- Be sure to set the paper cassette in the printer before you turn the power ON for the first time after you install the printer.

1 Press "I" of the power switch on the printer.

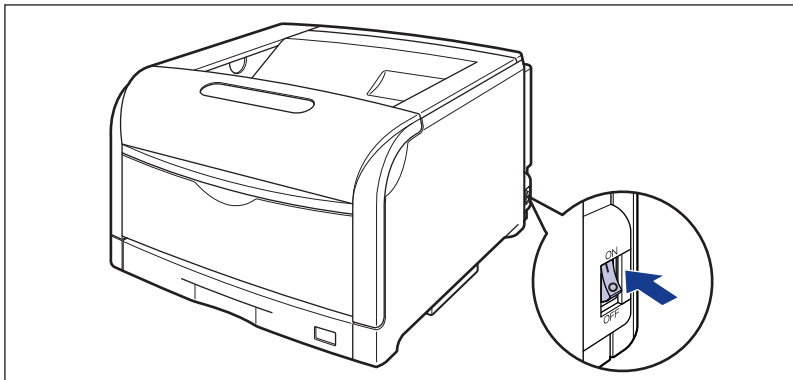

The indicators come on, and the printer initiates a self-diagnostic test on the printer unit and optional accessories.

If no abnormality is found during the self-diagnostic test, the 印刷可 indicator (blue) comes on, and the printer is ready to print.

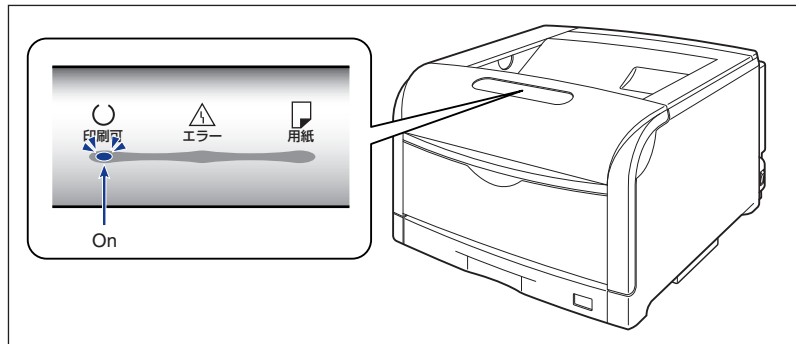

Turning the Printer OFF

Turn the printer OFF using the following procedure.

IMPORTANT

- If the printer is used on a network, make sure that it is not printing data from another computer before turning the printer OFF.
- If you turn the printer OFF, all the print data remaining in the printer memory will be deleted. So, wait for the necessary print data to be printed before turning the printer OFF.
- Do not turn the printer OFF when the printer is in any of the following status:
 - During printing
 - While the printer is running a self-diagnostic test immediately after turning the power ON

1 Press "○" of the power switch on the printer.

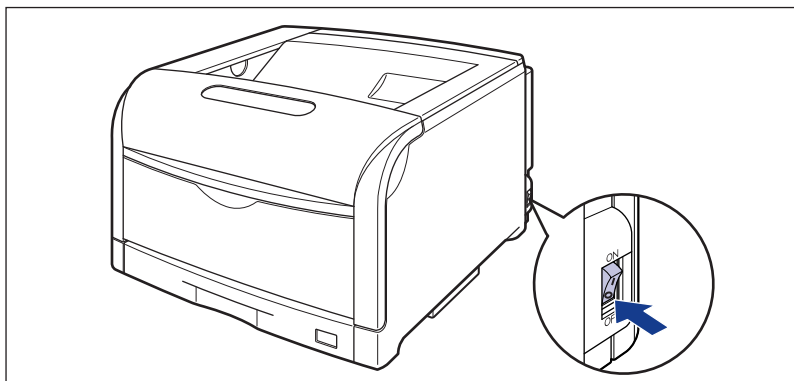

Online and Offline (Only for LBP5900SE)

"Online" is the status that the printer receives data from the computer and is possible to print, while "Offline" is the status that the connection with the computer is cut off and be impossible to receive data.

To perform the setting for each menu using the control panel, switch the printer status as follows:

- o: The status that can go into a menu.
- : The status that cannot go into a menu.

	When the printer is online	When the printer is offline
セットアップ menu	o*	O
キューシ センタク menu	O	O
リセット menu	O	O
ジョブ menu	O	-
ユーティリティ menu	O	-

* The setting ユーザメンテナンス options is not available in online status.

Placing the Printer Online

When printing from the computer, it is necessary that the printer is online. Before printing, make sure that the printer is online. If not, place the printer online using the following procedure. The printer comes online automatically after you turn it ON.

オンライン



1 Press [オンライン].

The オンライン indicator comes on, and the printer is ready to print.



IMPORTANT

- If an error is occurring in the printer (the メッセージ indicator is on, or numbers in the message is blinking), it cannot come online. Eliminate the cause of the error before you place the printer online.
- Be sure not to open the front cover and the paper cassette of the printer during printing. The printer may stop, disabling printing.

 NOTE

When the printer is switching to the sleep mode, the オンライン indicator is off and only the 印刷可 indicator comes on even if the printer is online. If the printer receives data in the sleep mode, the sleep mode is released, the オンライン indicator comes on, and the printer is ready to print.

Placing the Printer Offline

Set the printer to offline using the following procedure to prevent the printer from receiving data from the computer and to set all options of the セットアップ menu.



1 Press [オンライン].

The オンライン indicator comes off, and the printer is available to be set by the control panel.

 IMPORTANT

- If printing from the computer in offline, such as [プリンタの準備ができていません], and [プリンタが接続されていません] message are displayed, and the printer cannot print.
- The printer comes online automatically if left in the offline state for five minutes or longer. If an error is occurring in the printer (the メッセージ indicator is on, or numbers in the message is blinking), or the menu function, paper selection and setting of the paper size are being operated, the printer cannot set to online automatically.

Paper Requirements

To ensure optimum performance, use only paper that falls within the specifications in the following lists. Using inappropriate paper may result in deterioration in print quality or paper jams.

Usable Paper

The following shows the paper sizes that can be used with this printer. The "●" mark indicates that the paper is available for the 1-sided printing and automatic 2-sided printing; the "○" mark indicates that the paper is available for only 1-sided printing; and the "-" mark indicates that the printing cannot be performed.

IMPORTANT

- When continuously printing the paper of 279.4 mm wide (Letter size) or less, the safety function that prevents damages caused by heat may slow the print speed down in stages. (In case of plain paper of A5 or B5 size, the print speed may drop to approx. 8ppm, and in case of plain paper of B4 or postcard, the print speed may drop to approx. 4 ppm.)
- When printing with a resolution of 1200dpi, the print speed drops to approximately half.

Paper Size/Type for LBP5900SE

Paper Type	Paper Source				
	Multi-purpose Tray	Cassette 1	Cassette 2 (Optional)	Cassette 3 (Optional)	Cassette 4 (Optional)
Plain Paper (64-105g/m ²)					
A5	●	●	●	●	●
B5* ¹	●	●	●	●	●
A4* ¹	●	●	●	●	●
B4* ²	●	●	●	●	●
A3* ²	●	●	●	●	●
Letter* ¹	●	●	●	●	●
Executive* ¹	●	●	●	●	●
Legal* ²	●	●	●	●	●
Ledger (11 x 17)* ²	●	●	●	●	●
12 x 18* ²	○	-	-	-	-
Custom Paper Size	●* ³	-	●* ⁴	●* ⁴	●* ⁴
Long Size Paper* ²	○* ⁵	-	-	-	-
Postcard* ² 100.0mm x 148.0mm	○	-	-	-	-
Reply Postcard* ¹ 148.0mm x 200.0mm	○	-	-	-	-
4 on 1 Postcard* ¹ 200.0mm x 296.0mm	○	-	-	-	-

Paper Type	Paper Source				
	Multi-purpose Tray	Cassette 1	Cassette2 (Optional)	Cassette3 (Optional)	Cassette4 (Optional)
Heavy Paper (106-220g/m ²)					
A5-12 X 18	<input type="radio"/>	-	-	-	-
Custom Paper Size	<input type="radio"/> *3	-	-	-	-
Long Size Paper*2	<input type="radio"/> *5	-	-	-	-
Postcard*2 100.0mm x 148.0mm	<input type="radio"/>	-	-	-	-
Reply Postcard*1 148.0mm x 200.0mm	<input type="radio"/>	-	-	-	-
4 on 1 Postcard*1 200.0mm x 296.0mm	<input type="radio"/>	-	-	-	-
Coated Paper A3/A4	<input type="radio"/>	-	-	-	-
Label A4	<input type="radio"/>	<input type="radio"/>	<input type="radio"/>	<input type="radio"/>	<input type="radio"/>
Postcard*2 100.0mm x 148.0mm	<input type="radio"/>	-	-	-	-
Reply Postcard*1 148.0mm x 200.0mm	<input type="radio"/>	-	-	-	-
4 on 1 Postcard*1 200.0mm x 296.0mm	<input type="radio"/>	-	-	-	-
Envelope*2					
YOUGATA No.4 105.0mm x 235.0mm	<input type="radio"/>	-	-	-	-
YOUGATA No.2 114.0mm x 162.0mm	<input type="radio"/>	-	-	-	-
KAKUGATA No.2 240.0mm x 332.0mm	<input type="radio"/>	-	-	-	-

*1 Paper can be loaded only in landscape orientation.

*2 Paper can be loaded only in portrait orientation.

*3 The following sizes of custom paper can be loaded.

In case of portrait orientation: Width 98.0-312.0mm, Length 148.0-457.2mm

In case of landscape orientation: Width 210.0-297.0mm, Length 148.0-297.0mm

The following sizes of custom paper (plain paper) can be printed by automatic 2-sided printing.

In case of portrait orientation: Width 210.0-297.0mm, Length 210.0-431.8mm

In case of landscape orientation: Width 210.0-297.0mm, Length 148.0-297.0mm

*4 The following sizes of custom paper can be loaded.

In case of portrait orientation: Width 210.0-297.0mm, Length 210.0-431.8mm

In case of landscape orientation: Width 210.0-297.0mm, Length 148.0-297.0mm

*5 The following sizes of long size paper can be loaded in portrait orientation. This can be printed by only LIPS LX printer driver.

Width 210.0-297.0mm, Length 457.3-1,200.0mm

Paper Size/Type for LBP5600SE

Paper Type	Paper Source				
	Multi-purpose Tray	Cassette 1	Cassette 2 (Optional)	Cassette 3 (Optional)	Cassette 4 (Optional)
Plain Paper (64-105g/m ²)					
A5	●	●	●	●	●
B5* ¹	●	●	●	●	●
A4* ¹	●	●	●	●	●
B4* ²	●	●	●	●	●
A3* ²	●	●	●	●	●
Letter* ¹	●	●	●	●	●
Executive* ¹	●	●	●	●	●
Legal* ²	●	●	●	●	●
Ledger (11 x 17)* ²	●	●	●	●	●
12 x 18* ²	○	-	-	-	-
Custom Paper Size	●* ³	-	●* ⁴	●* ⁴	●* ⁴
Long Size Paper* ²	○* ⁵	-	-	-	-
Heavy Paper (106-220g/m ²)					
A5-12 X 18	○	-	-	-	-
Custom Paper Size	○* ³	-	-	-	-
Long Size Paper* ²	○* ⁵	-	-	-	-
Coated Paper A3/A4	○	-	-	-	-
Label A4	○	○	○	○	○

Paper Type	Paper Source				
	Multi-purpose Tray	Cassette 1	Cassette2 (Optional)	Cassette3 (Optional)	Cassette4 (Optional)
Envelope*2					
Envelope DL 110.0 mm x 220.0 mm	○	-	-	-	-
Envelope COM10 105.0 mm x 241.0 mm	○	-	-	-	-
Envelope C5 162.0 mm x 229.0 mm	○	-	-	-	-
Envelope Monarch 98.0 mm x 191.0 mm	○	-	-	-	-
Envelope B5 176.0 mm x 250.0 mm	○	-	-	-	-

*1 Paper can be loaded only in landscape orientation.

*2 Paper can be loaded only in portrait orientation.

*3 The following sizes of custom paper can be loaded.

In case of portrait orientation: Width 98.0-312.0mm, Length 148.0-457.2mm

In case of landscape orientation: Width 210.0-297.0mm, Length 148.0-297.0mm

The following sizes of custom paper can be printed by automatic 2-sided printing.

In case of portrait orientation: Width 210.0-297.0mm, Length 210.0-431.8mm

In case of landscape orientation: Width 210.0-297.0mm, Length 148.0-297.0mm

*4 The following sizes of custom paper can be loaded.

In case of portrait orientation: Width 210.0-297.0mm, Length 210.0-431.8mm

In case of landscape orientation: Width 210.0-297.0mm, Length 148.0-297.0mm

*5 The following sizes of long size paper can be loaded in portrait orientation.

Width 210.0-297.0mm, Length 457.3-1,200.0mm

Abbreviations of Paper Sizes

The following shows the abbreviations of paper sizes that are marked on the paper cassette.

Paper size	Paper size setting switch of paper cassette
Ledger (11 x 17)	11 x 17
Legal	LGL
Letter	LTR
Executive	EXEC
Custom Paper Size*	CUSTOM

*Only optional paper feeder.

■ Plain Paper for LBP5900SE

This printer can print Plain paper of the standard paper sizes (A3, B4, A4, B5, A5, 12 x 18, Ledger (11X17), Legal, Letter, Executive, Postcard, Reply postcard, 4 on 1 postcard), Custom paper size, and Long size paper. Plain paper that weighs between 64 and 105 g/m² can be printed.

Standard paper (other than Postcard, Reply postcard, 4 on 1 postcard) can be loaded in the paper cassettes and multi-purpose tray. Plain paper of Postcard, Reply postcard, and 4 on 1 postcard can be loaded in the multi-purpose tray. Automatic 2-sided printing can be performed on paper of A3, B4, A4, B5, A5, Ledger (11X17), Letter, Legal, and Executive sizes.

Custom paper size and Long Size Paper can be loaded in the multi-purpose tray. Automatic 2-sided printing can be performed on Custom paper size in the multi-purpose tray. By installing the optional paper feeder, Custom paper size can be loaded in the cassette 2, 3, 4, and automatic 2- sided printing can be performed.

■ Plain Paper for LBP5600SE

This printer can print Plain paper of the standard paper sizes (A3, B4, A4, B5, A5, 12-18, Ledger (11X17), Legal, Letter, Executive), Custom paper size, and Long size paper. Plain paper that weighs between 64 and 105 g/m² can be printed.

Standard paper can be loaded in the paper cassettes and multi-purpose tray. Automatic 2-sided printing can be performed on paper of A3, B4, A4, B5, A5, Ledger (11X17), Letter, Legal, and Executive sizes.

Custom paper size and Long Size Paper can be loaded in the multi-purpose tray. Automatic 2-sided printing can be performed on Custom paper size in the multi-purpose tray. By installing the optional paper feeder, Custom paper size can be loaded in the cassette 2, 3, 4, and automatic 2- sided printing can be performed.

■ Heavy Paper

This printer can print Heavy paper of the standard paper sizes (A3, B4, A4, B5, A5, 12 x 18, Ledger (11X17), Legal, Letter, Executive), Custom paper size, and Long size paper. And Heavy paper that weighs between 106 and 220 g/m² can be printed.

Heavy paper can be loaded in the multi-purpose tray, and only 1-sided printing can be performed.

■ Coated Paper

This printer can print A3 and A4 size coated paper. Load coated paper in the multi-purpose tray.



IMPORTANT

Use "A3 size coated paper that Canon recommends", and "A4 size coated paper that Canon recommends".

■ Label

This printer can print A4 size labels. Labels can be loaded in the paper cassettes and multi-purpose tray.

 **IMPORTANT**

- Use "A4 size label that Canon recommends".
- Do not use the labels in the following conditions. Using inappropriate labels may result in paper jams that are difficult to clear or may result in damage to the printer.
 - Peeled labels or partly used labels
 - Coated labels that are easily peeled off from the backing sheet
 - Labels with uneven adhesive

■ Postcard / Reply postcard / 4 on 1 postcard (Only for LBP5900SE)

This printer can print Postcard, Reply postcard, 4 on 1 postcard and 4 on 1 postcard recommended by Canon. Load Postcard, Reply postcard, and 4 on 1 postcard with the printing side facing down in the multi-purpose tray.

 **IMPORTANT**

- Printing inappropriate size postcard (other than Postcard, Reply postcard, 4 on 1 postcard, and 4 on 1 postcard recommended by Canon) may cause deterioration in print quality or paper jams.
- Reply postcard that is not creased can be printed.
- If the postcard is curled, flatten the curls by warping it in the opposite direction before loading it.
- Postcard and Reply postcard for ink jet printers cannot be printed.
- Postcard cannot be loaded in landscape orientation. Be sure to load postcard with the printed side facing down in portrait orientation.

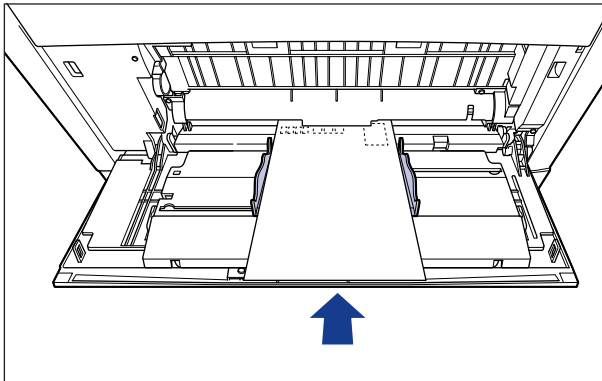

- Reply postcard and 4 on 1 postcard cannot be loaded in portrait orientation. Be sure to load Reply postcard or 4 on 1 postcard with the printed side facing down in landscape orientation.

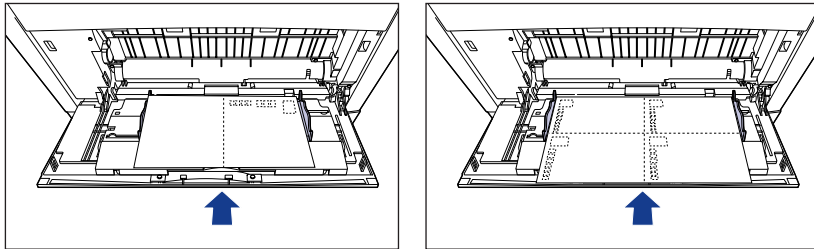

- Printing speed drops when printing postcard and Reply postcard.

■ Envelope for LBP5900SE

The envelopes that can be used with this printer are YOUGATA No.4, YOUGATA No.2, and KAKUGATA No.2, and the one that have the following structures only. Load the stack of envelopes with the address side (non-glued side) facing down in the multi-purpose tray.

YOUGATA No.4
(105 mm x 235 mm)
(Envelope Y401 for Canon LBP
/recommended)

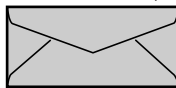

YOUGATA No.2
(114 mm x 162 mm)
(Envelope Y201 for Canon LBP/
recommended)

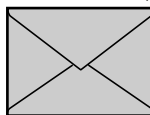

KAKUGATA No.2
(240 mm x 332 mm)

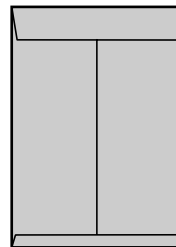

*Envelopes of YOUGATA No.4 and YOUGATA No.2 with a flap on the short edge cannot be used.



IMPORTANT

- Do not use the following types of envelopes. Using inappropriate envelopes may result in paper jams that are difficult to clear or may result in damage to the printer.
 - Envelopes with fasteners or snaps
 - Envelopes with address windows
 - Envelopes with adhesive on the surface
 - Wrinkled or creased envelopes
 - Poorly manufactured envelopes in which the glued parts are uneven
 - Irregularly-shaped envelopes
- Before loading the envelopes, flatten the stack of envelopes to release any remaining air, and press the fold lines along the edges tight.
- Do not print on the reverse side (glued side) of envelopes.

- When loading YOUGATA No.4 and YOUGATA No.2, load them so that the flap is toward the left of the printer when viewed from the front.

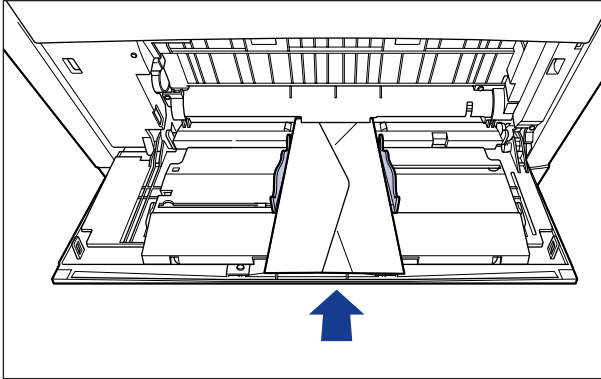

- When loading envelopes at size of KAKUGATA No.2, leave the flaps open and load them so that the bottom of the envelopes is toward the back of the printer when viewed from the front.

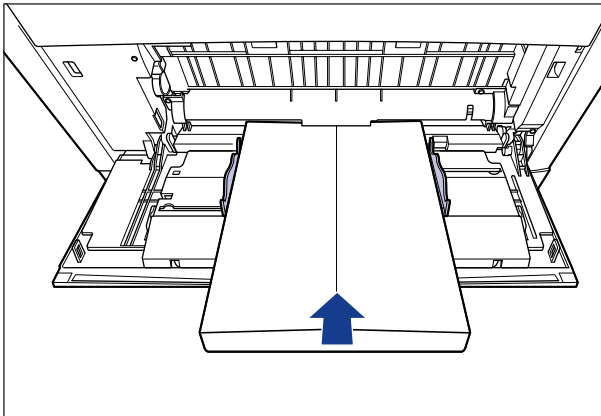

- Printing speed drops when printing envelopes.

 NOTE

When printing envelopes, they may be creased.

■ **Envelope for LBP5600SE**

The envelopes that can be used with this printer are Envelope DL, Envelope COM10, Envelope C5, Envelope Monarch, and Envelope B5, and the one that have the following structures only. Load the stack of envelopes with the address side (non-glued side) facing down in the multi-purpose tray.



IMPORTANT

- The printable envelope types are shown below:

Envelope DL
110.0 mm x 220.0 mm

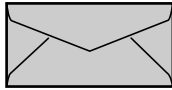

Envelope Monarch
98.0 mm x 191.0 mm

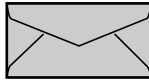

Envelope B5
176.0 mm x 250.0 mm



Envelope COM10
105.0 mm x 241.0 mm

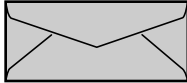

Envelope C5
162.0 mm x 229.0 mm

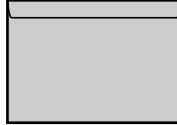

* You cannot use envelopes at sizes of DL, COM10, Monarch, and C5 that have a flap on the short edge.

- Do not use the following types of envelopes. Using inappropriate envelopes may result in paper jams that are difficult to clear or may result in damage to the printer.
 - Envelopes with fasteners or snaps
 - Envelopes with address windows
 - Envelopes with adhesive on the surface
 - Wrinkled or creased envelopes
 - Poorly manufactured envelopes in which the glued parts are uneven
 - Irregularly-shaped envelopes
- Before loading the envelopes, flatten the stack of envelopes to release any remaining air, and press the fold lines along the edges tight.
- Do not print on the reverse side (glued side) of envelopes.
- When loading DL, COM10, C5 or Monarch, load them so that the flap is toward the left of the printer when viewed from the front.

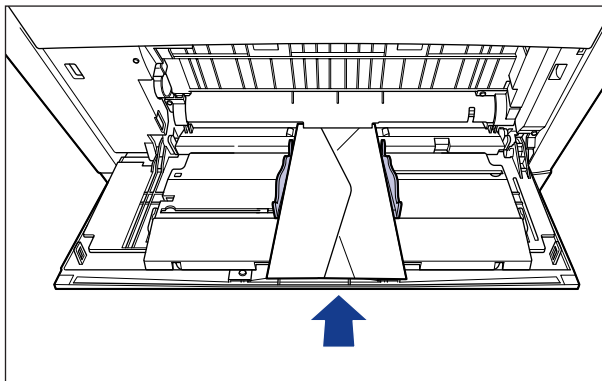

- When loading envelopes at size of Envelope B5, close the flaps and load them so that the bottom of the envelopes is toward the front of the printer when viewed from the front.

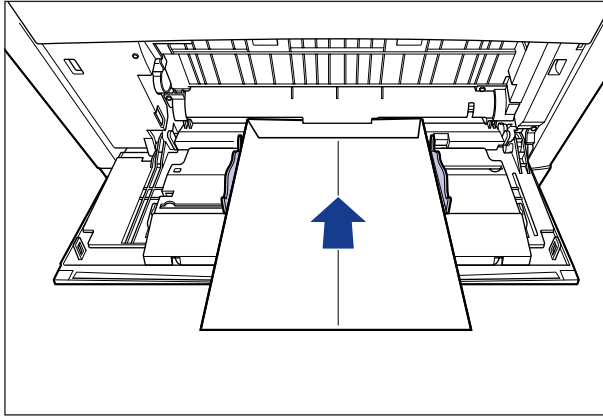

- Printing speed drops when printing envelopes.

 NOTE

When printing envelopes, they may be creased.

Printable Area

The following shows the printable area of this printer. If you have selected the [Print with Upper Left of Sheet as Starting Point] check box in the [Finishing Details] dialog box in the printer driver, however, you can extend the printable area to near the edges of the paper. For more details, see Online Help in the printer driver.

■ Plain Paper / Heavy Paper / Coated Paper / Label

You cannot print on any area within 5 mm of the edges of paper.

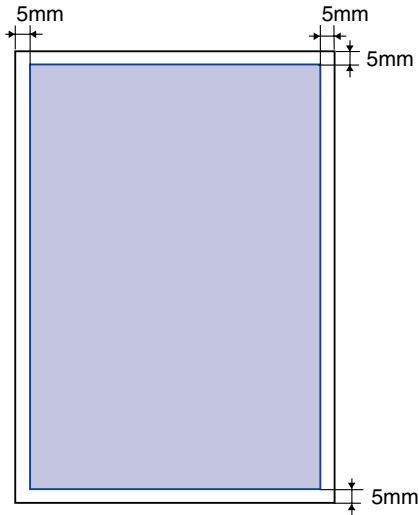

■ Postcard / Reply postcard / 4 on 1 postcard (Only for LBP5900SE)

You cannot print on any area within 5 mm of the edges of postcard.

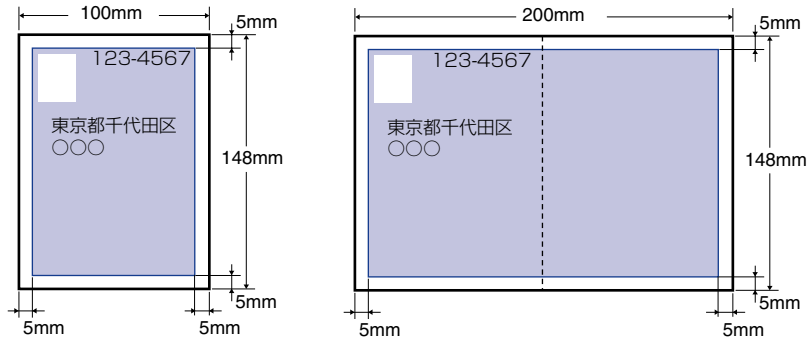

■ Envelopes

You cannot print on any area within 10 mm of the edges of an envelope.

You may have to change the printable area before printing, depending on the application you use.

Sample: YOUGATA No.4 (LBP5900SE)

Sample: Envelope COM 10 (LBP5600SE)

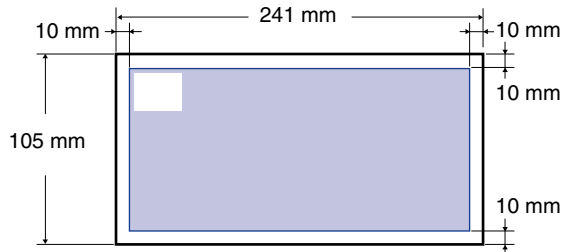
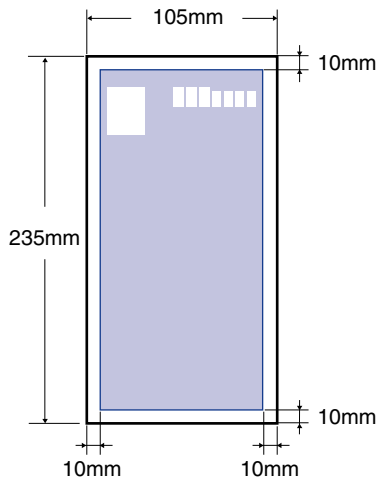

Unusable Paper

To avoid problems such as paper jams and other malfunctions, the following types of paper should never be used:

🚫 IMPORTANT

- Paper that jams easily
 - Paper that is too thick or too thin
 - Irregularly-shaped paper
 - Wet or moist paper
 - Torn or damaged paper
 - Rough, extremely smooth, or glossy paper
 - Paper with binding holes or perforations
 - Curled or creased paper
 - Specially coated paper (coated paper for ink jet printers, etc.)
 - Labels with backing sheet that is easily peeled off
 - Paper that has already been printed by a copy machine or another laser printer (The reverse side of the paper is also unusable.). Using the multi-purpose tray, however, you can perform 2-sided printing manually on the back of previously printed paper. You cannot print on the printed side again.
 - Paper with jagged edges
 - Wrinkled paper
 - Paper with the corners folded
- Paper that changes its quality at a high temperature

- Paper that contains ink that melts, burns, evaporates or emits harmful gases with the heat (approx. 190 °C) of the fixing unit
- Heat-sensitive paper
- Treated color paper
- Specially coated paper (coated paper for ink jet printers, etc.)
- Paper with adhesive on the surface
- Paper that causes printer malfunctions or damages the printer
 - Carbon paper
 - Paper with staples, clips, ribbons or tapes
 - Paper that has already been printed by a copy machine or another laser printer (The reverse side of the paper is also unusable.). Using the multi-purpose tray, however, you can perform 2-sided printing manually on the back of previously printed paper. You cannot print on the printed side again.
- Paper that is difficult for the toner to fix onto
 - Paper with rough surfaces
 - Specially coated paper (coated paper for ink jet printers, etc.)
 - Paper containing thick fibers

Paper Capacity of Paper Source

Paper Type	Paper Source				
	Multi-purpose Tray	Cassette 1	Cassette 2 (Optional)	Cassette 3 (Optional)	Cassette 4 (Optional)
Plain Paper (When plain paper that weighs 64g/m ² is used)	Approx. 100 sheets	Approx. 250 sheets	Approx. 550 sheets	Approx. 550 sheets	Approx. 550 sheets
Heavy Paper (When heavy paper that weighs 128g/m ² is used)	Approx. 50 sheets	-	-	-	-
Coated Paper	Approx. 50 sheets	-	-	-	-
Labels	Approx. 40 sheets	Approx. 50 sheets	Approx. 50 sheets	Approx. 50 sheets	Approx. 50 sheets
Postcard (Only for LBP5900SE)	Approx. 40 sheets	X	X	X	X
Reply Postcard (Only for LBP5900SE)	Approx. 40 sheets	X	X	X	X
4 on 1 Postcard (Only for LBP5900SE)	Approx. 40 sheets	X	X	X	X
Envelopes	Approx. 10 sheets	X	X	X	X

Paper Capacity of the Output Tray

Paper Type	Output Tray*
	Face-down Output Tray
Plain Paper (When plain paper that weighs 64 g/m ² is used)	Approx. 250 sheets
Heavy Paper (When heavy paper that weighs 128g/m ² is used)	Approx. 200 sheets
Coated Paper	Approx. 150 sheets
Labels	Approx. 100 sheets
Postcard (Only for LBP5900SE)	Approx. 50 sheets
Reply Postcard (Only for LBP5900SE)	Approx. 50 sheets

Paper Type	Output Tray*
	Face-down Output Tray
4 on 1 Postcard (Only for LBP5900SE)	Approx. 50 sheets
Envelopes	Approx. 20 sheets

* Actual paper capacity varies depending on the installation environment or paper type.

Loading Paper in the Paper Cassette

Different sizes of paper can be loaded in Cassette 1 supplied with the printer and in Cassette 2, 3, and 4 that are available when the optional paper feeders are installed. Then, you can switch among these paper sources automatically.

Since the paper loading procedures for Cassette 1 and for the optional Cassette 2 to 4 differ, load paper properly using the following procedure.



IMPORTANT

- When printing, be sure not to open the cover and pull the paper cassette out. The printer may stop and may not print.
- Follow the instructions below not to result in paper jams.
 - Do not load any paper other than plain paper (64-105 g/m²) such as postcard and envelope, and label. For more details on the paper that can be loaded, see "Paper Requirements," on p. 12.
 - Do not load paper with jagged edges, creased, or extremely curled paper.
 - Refill the cassette after paper runs out. If the cassette is refilled when paper still remains in the cassette, it may result in misfeeds.
 - Be sure that the paper stack does not exceed the load limit marks on the paper guides. If the paper stack exceeds the load limit marks, this may result in misfeeds.
- Do not touch the black rubber pad in the cassette 1, and the paper feed rollers in the cassette 2, 3, and 4. This may result in misfeeds.
 - Cassette 1

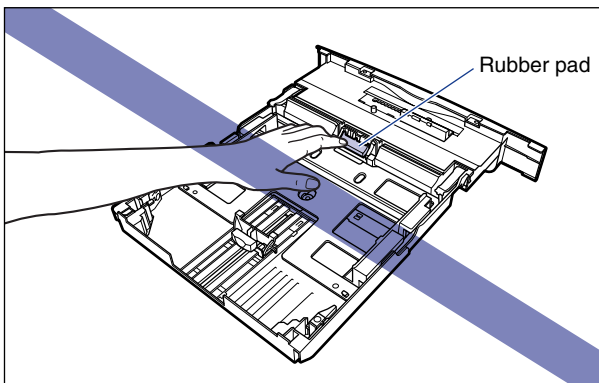

- Cassette 2, 3, and 4

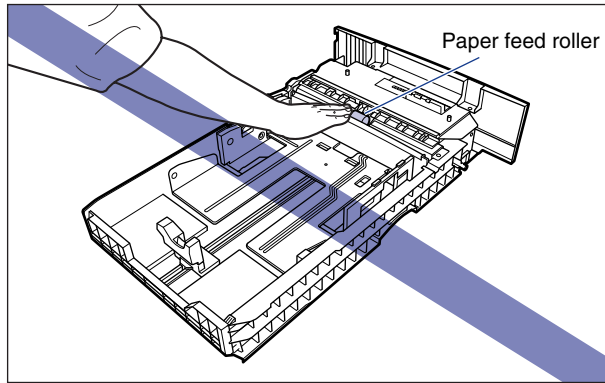

When Loading Paper in Cassette 1

1 Pull the paper cassette out.

Pull the paper cassette out until it stops ①.

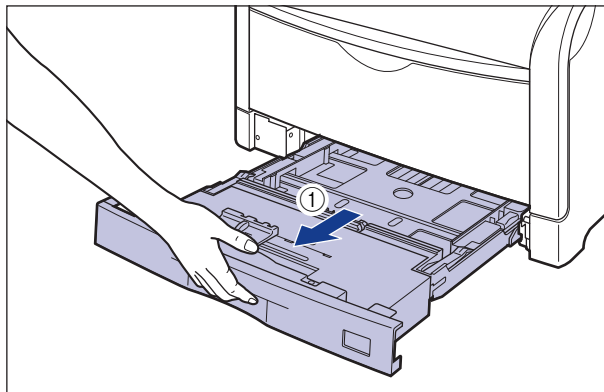

After lifting the paper cassette up a little ②, pull it out while supporting it with other hand as shown in the figure ③.

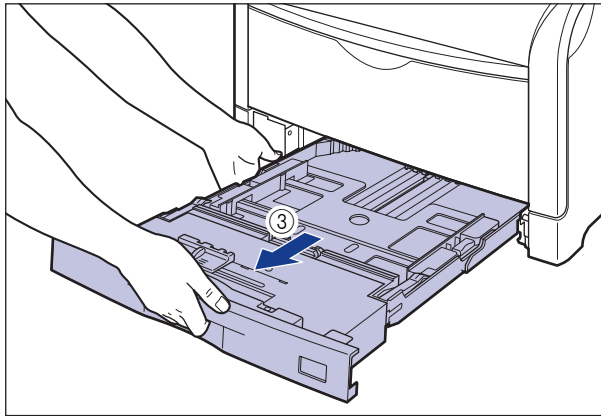
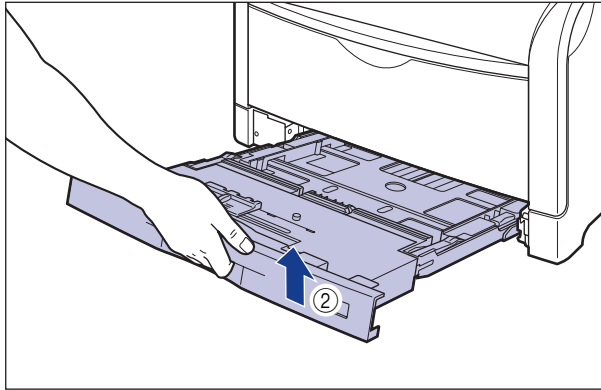

⚠ CAUTION

Be sure to take the paper cassette out of the printer before loading paper. If paper is loaded while the paper cassette is partially pulled out, the paper cassette may drop or the printer may become damaged resulting in personal injury.

🚫 IMPORTANT

The paper cassette cannot be pulled out horizontally. If you try to pull it out forcefully, this may result in damage to the paper cassette.

2 Adjust the length of the paper cassette according to the size of the paper to be loaded.

When loading paper in landscape orientation, such as when loading A4, B5, A5, Letter, or Executive size paper, shorten the paper cassette.

When loading paper in portrait orientation, such as when loading A3, B4, Ledger (11X17), or Legal size paper, extend the paper cassette.

To adjust the length of the paper cassette, push up the lock release levers gently to release the lock, slide the paper cassette by holding the rear portion of the paper cassette, and then push down the lock release levers to lock the cassette.

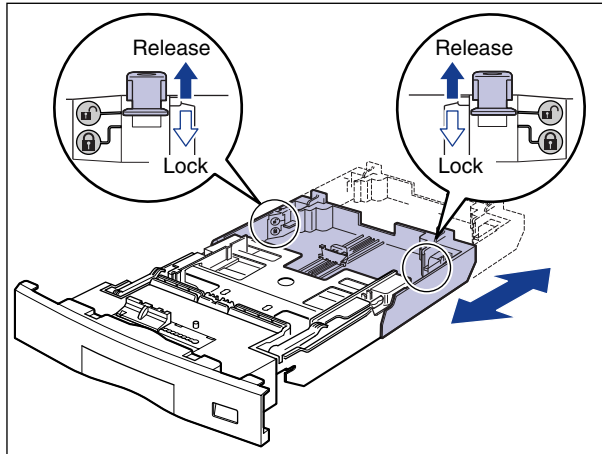

3 While holding the lock release lever of the rear paper guide, slide the guide to the mark for the size of the paper to be loaded.

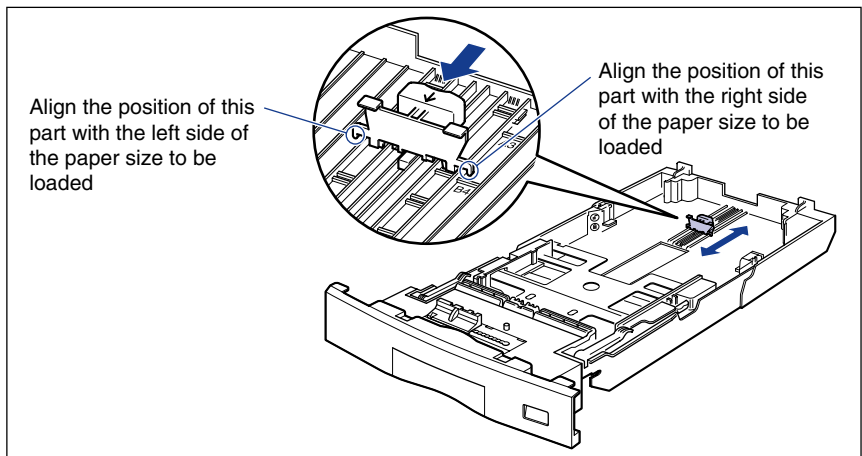

- 4** While holding the lock release lever of the side paper guide, slide the guide to the mark for the size of the paper to be loaded.

The side paper guides move together.

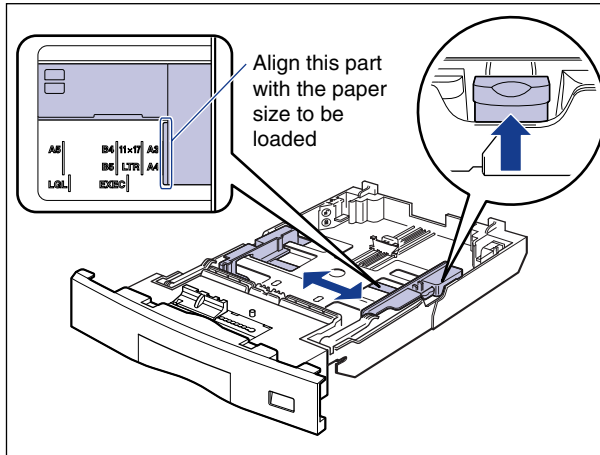

- 5** When loading labels, fan them in small batches and align the edges.

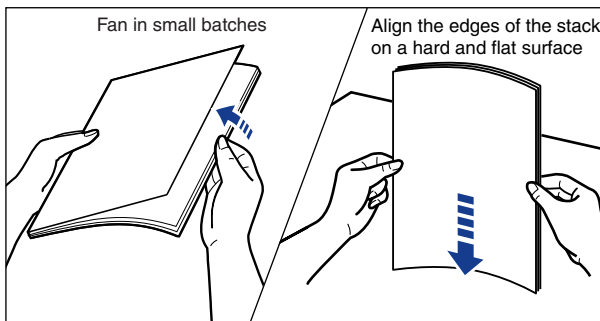

⚠ CAUTION

When loading paper, take care not to cut your hands with the edges of the paper.

👉 IMPORTANT

Be sure to fan the labels thoroughly before loading them. If they are not fanned enough, multiple sheets of paper may be fed at once, causing paper jams.

- 6** Load the paper stack so that the rear edge is aligned with the paper guide.

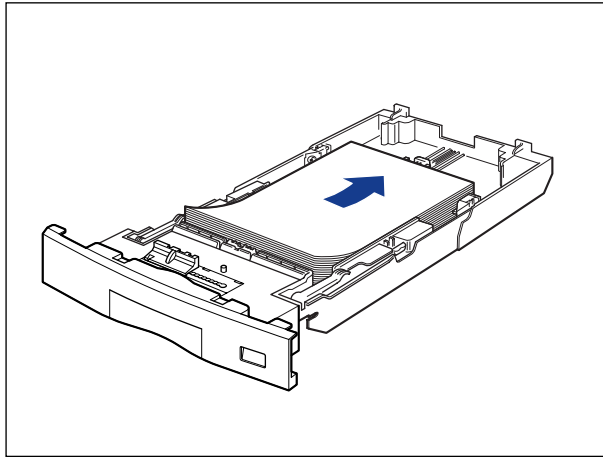

CAUTION

When loading paper, take care not to cut your hands with the edges of the paper.



IMPORTANT

If you use paper that has been poorly cut, multiple sheets of paper may be fed at once. In this case, align the edges of the stack on a hard, flat surface.

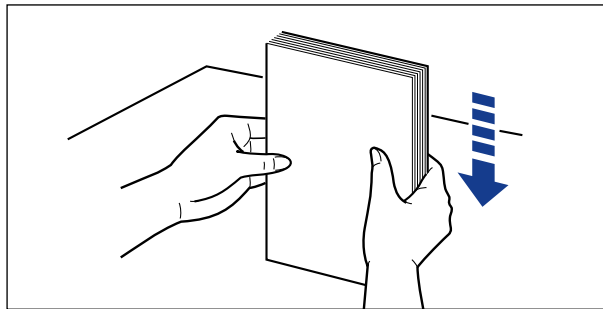

 NOTE

- To print letterhead paper or paper printed with a logo, load the paper in the proper orientation according to the following instructions:
 - When loading paper in landscape orientation, such as when loading A4, B5, A5, Letter, or Executive size paper, load the paper so that the printing side is facing up and as shown in the following figures.

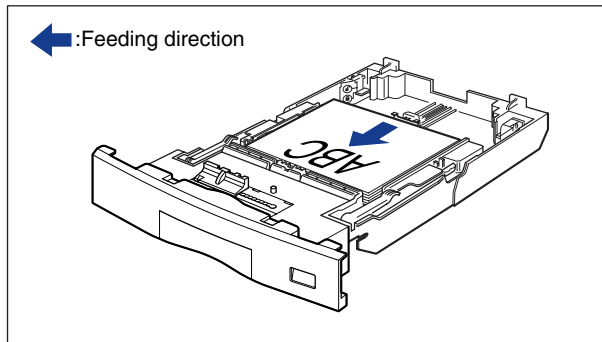
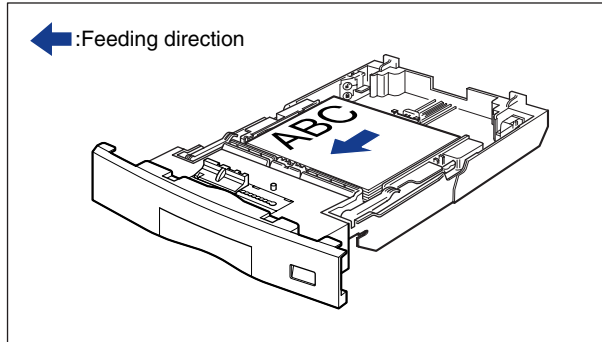

- When loading paper in landscape orientation, such as when loading A3, B4, Ledger, and Legal size paper, load the paper so that the printing side is facing up and as shown in the following figures.

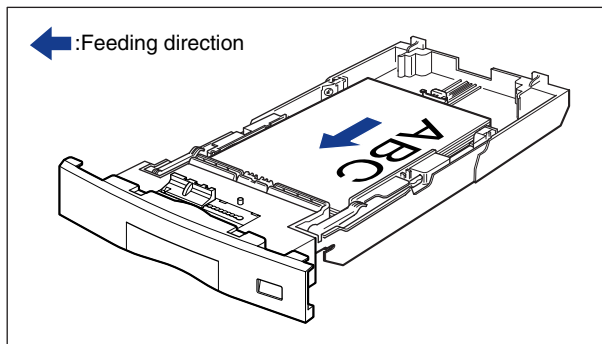
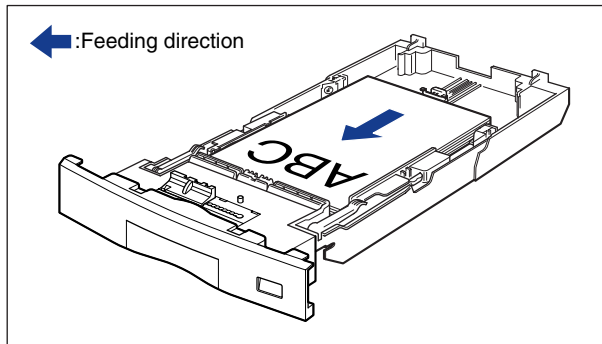

7 Press down the paper stack so that it is loaded under the hooks on the side paper guides.

Make sure that there is sufficient space between the hooks and paper stack. If there is no sufficient space, slightly reduce the amount of paper.

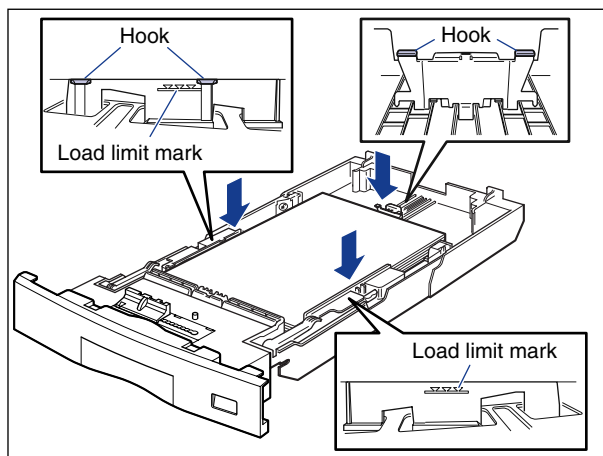

IMPORTANT

Up to approximately 250 sheets of plain paper (64 g/m²) or approximately 50 sheets of labels can be loaded in the paper cassette. Be sure that the paper stack does not exceed the load limit marks on the paper guides. If the paper stack exceeds the load limit marks, this may result in misfeeds.

- 8 Attach the label for the size of the loaded paper to the paper size indicator, and insert the guide into the paper size slot at the front of the paper cassette.**

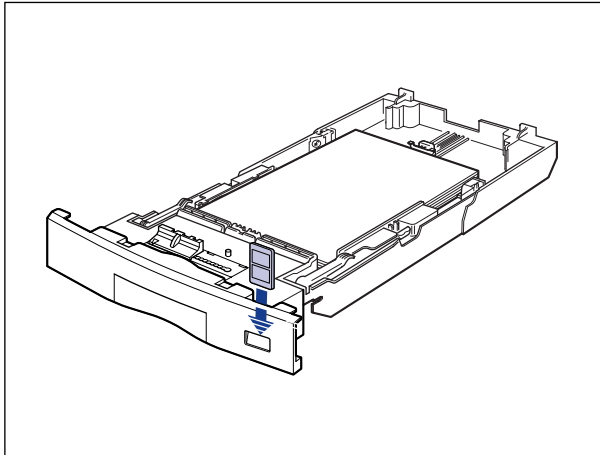

- 9 Hold the tab of the paper size setting switch, and align the paper size with the triangular mark of the paper size setting switch**

The default is "A4".

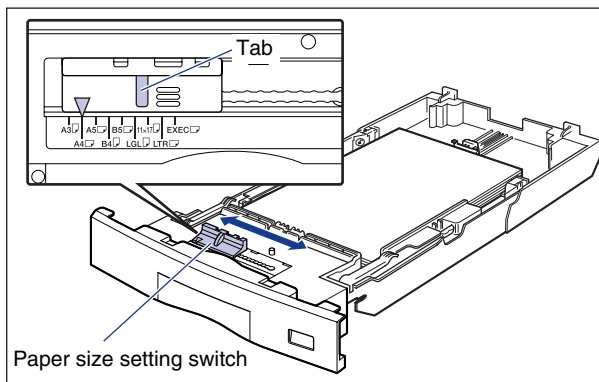

IMPORTANT

Make sure that the size of the loaded paper matches that of the paper size setting switch before setting the paper cassette in the printer. If the size indicated by the paper size setting switch does not match, this may result in printer malfunction.

10 Set the paper cassette in the printer.

While holding the paper cassette with both hands and insert it until it stops ① as shown in the figure.

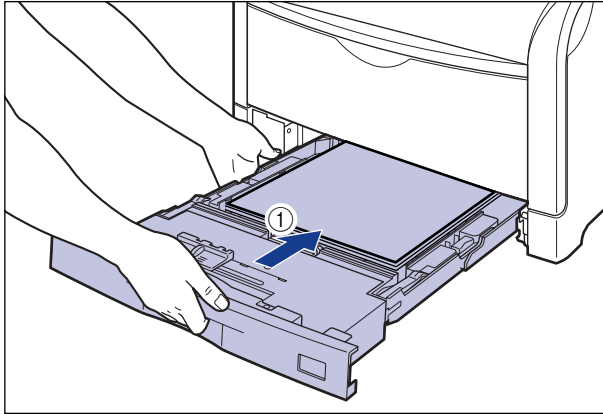

After lifting the front of the paper cassette up a little ②, push the paper cassette into the printer firmly until the front side of the paper cassette is flush with the front surface of the printer ③.

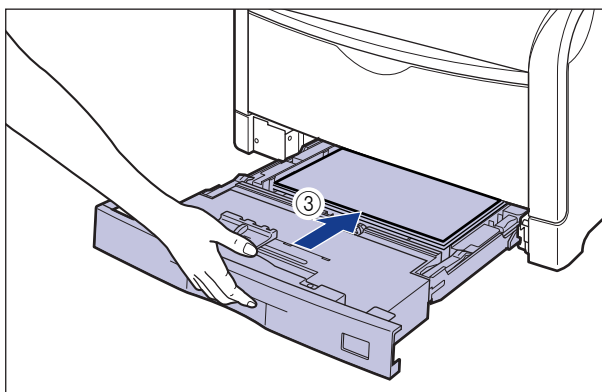
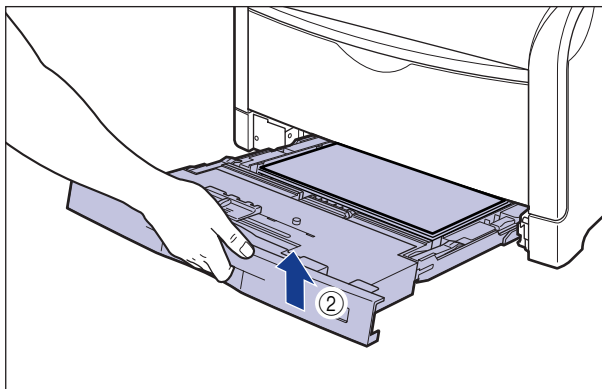

When Loading Standard Size Paper in Cassette 2, 3, or 4

1 Pull the paper cassette out.

Pull the paper cassette out until it stops ①.

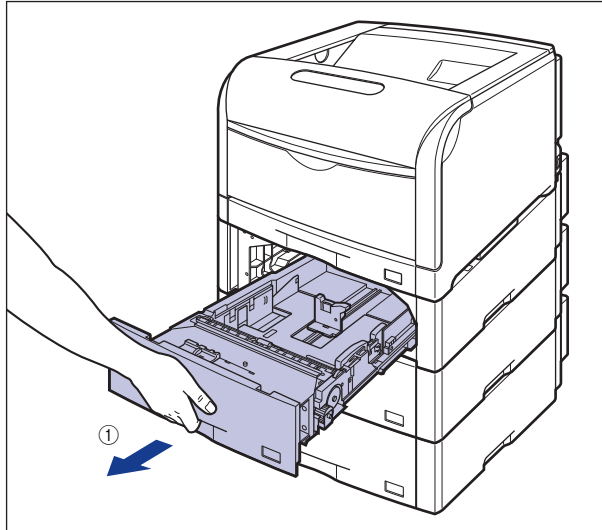

After lifting the paper cassette up a little ②, pull it out while supporting the cassette with your left hand until the handle on the right side of the paper cassette appears completely ③.

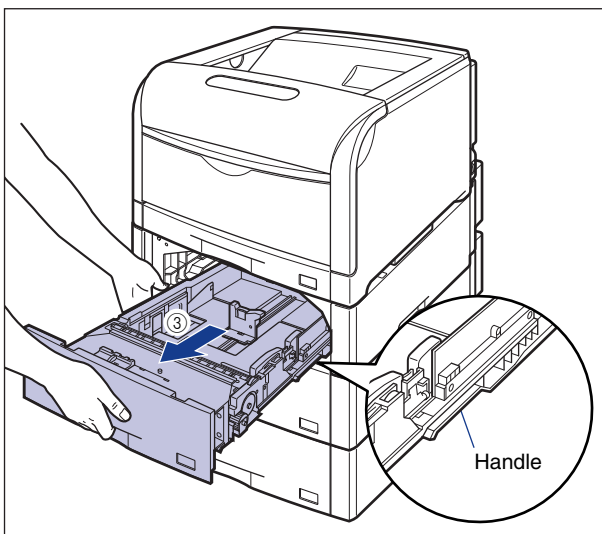
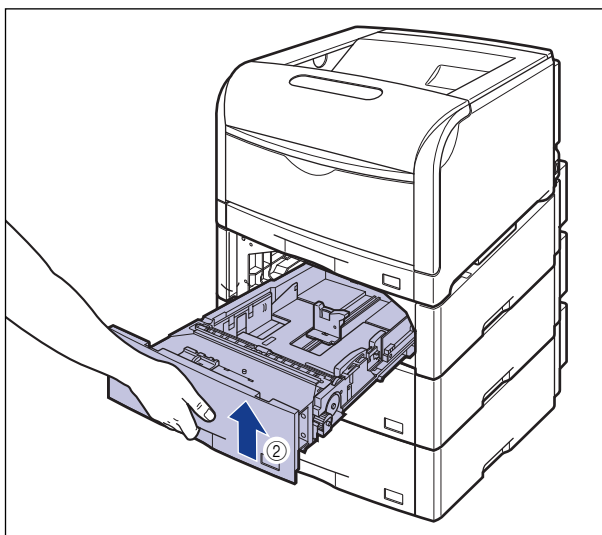

While holding the paper cassette with both hands, pull it out completely ④ as shown in the figure.

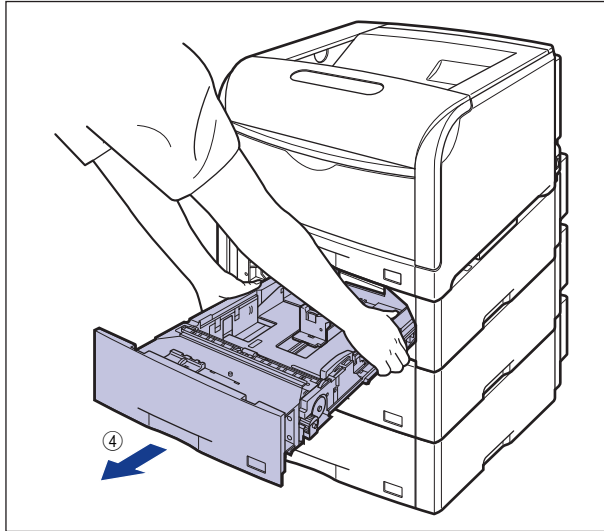

⚠ CAUTION

Be sure to take the paper cassette out of the paper feeder before loading paper. If paper is loaded while the paper cassette is partially pulled out, the paper cassette may drop or the printer may become damaged resulting in personal injury.

👤 IMPORTANT

- The paper cassette cannot be pulled out horizontally. If trying to pull it out forcefully, this may result in damage to the paper cassette.
- Because the paper cassette is heavy, hold it with your both hands securely.
- Place the removed paper cassette on an even and stable surface.

- 2** While holding the lock release lever of the rear paper guide, slide the guide to the mark for the size of the paper to be loaded.

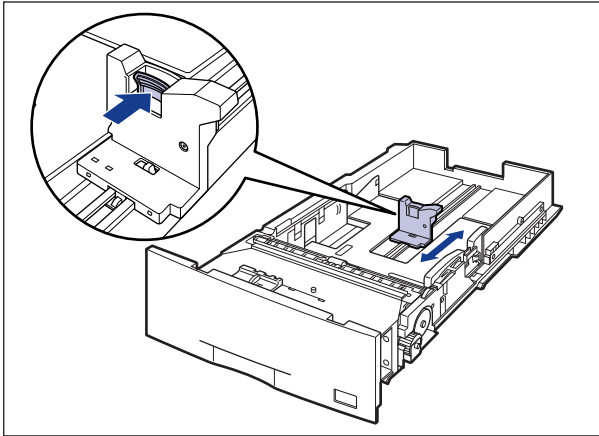

- 3** While holding the lock release lever of the side paper guide, slide the guide to the mark for the size of the paper to be loaded.

The side paper guides move together.

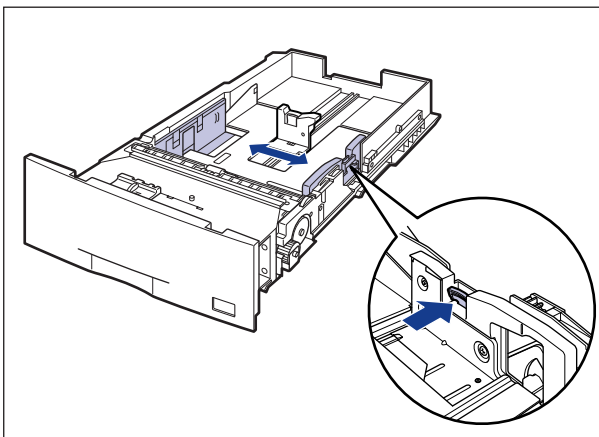

4 When loading labels, fan them in small batches and align the edges.

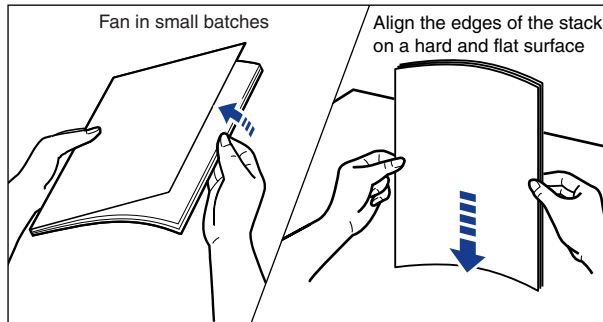

CAUTION

When loading paper, take care not to cut your hands with the edges of the paper.

NOTE

Be sure to fan the labels thoroughly before loading them. If they are not fanned enough, multiple sheets of paper may be fed at once, causing paper jams.

5 Load the paper stack so that the rear edge is aligned with the paper guide.

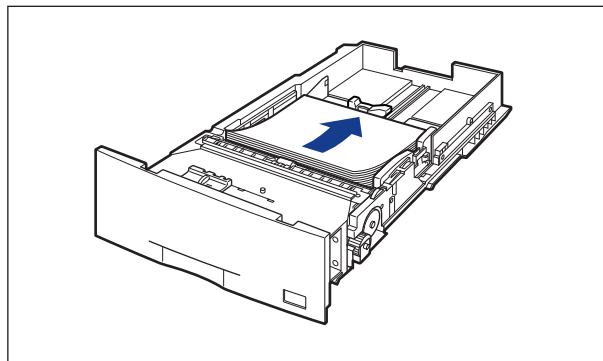



CAUTION

When loading paper, take care not to cut your hands with the edges of the paper.

 **IMPORTANT**

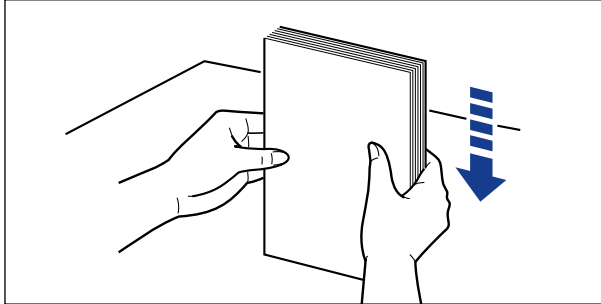
If you use paper that has been poorly cut, multiple sheets of paper may be fed at once. In this case, align the edges of the stack on a hard, flat surface.



 **NOTE**

To print letterhead paper or paper printed with a logo, load the paper in the proper orientation according to the following instructions:

- When loading paper in landscape orientation, such as when loading A4, B5, A5, Letter, or Executive size paper, load the paper so that the printing side is facing up and as shown in the following figures.

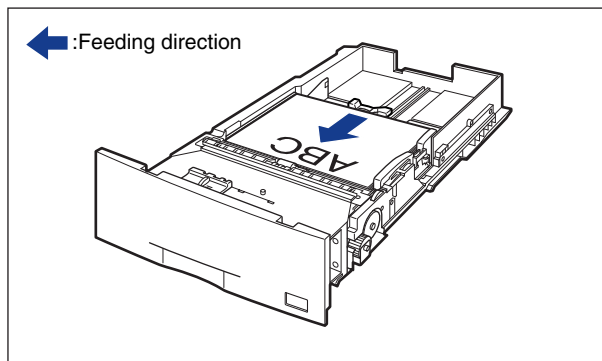
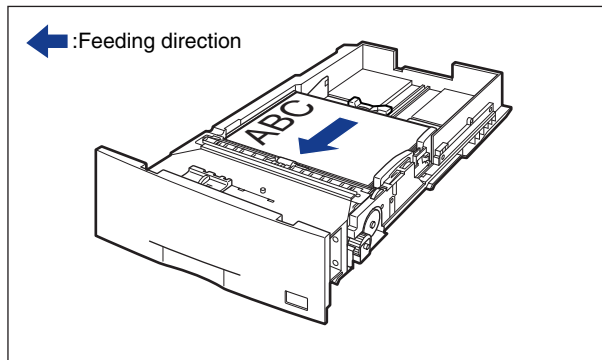

- When loading paper in landscape orientation, such as when loading A3, B4, Ledger, and Legal size paper, load the paper so that the printing side is facing up and as shown in the following figures.

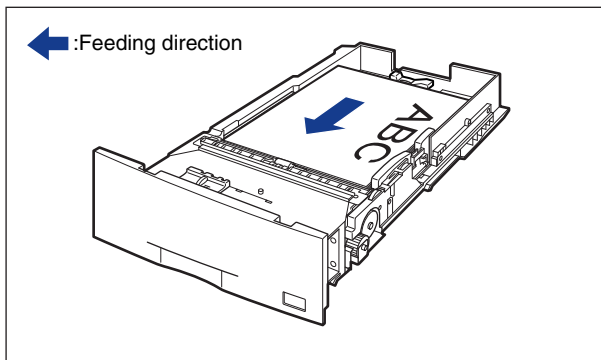
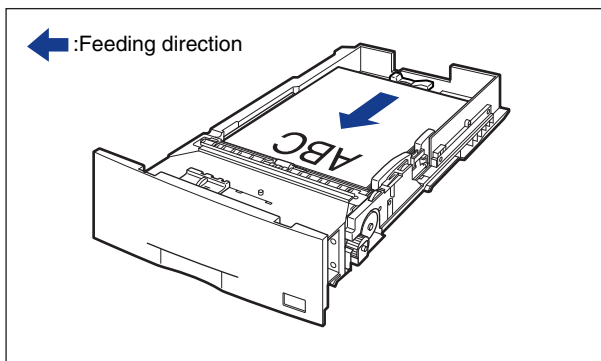

6 Press down the paper stack so that it is loaded under the hooks on the side paper guides.

Make sure that there is sufficient space between the hooks and paper stack. If there is no sufficient space, slightly reduce the amount of paper.

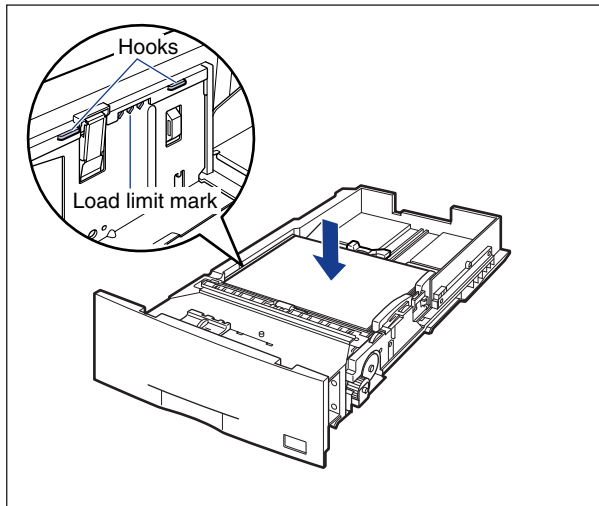

IMPORTANT

Up to approximately 550 sheets of plain paper (64 g/m²) or approximately 50 sheets of labels can be loaded in the paper cassette. Be sure that the paper stack does not exceed the load limit marks on the paper guides. If the paper stack exceeds the load limit marks, this may result in misfeeds.

7 Attach the label for the size of the loaded paper to the paper size indicator, and insert the guide into the paper size slot at the front of the paper cassette.

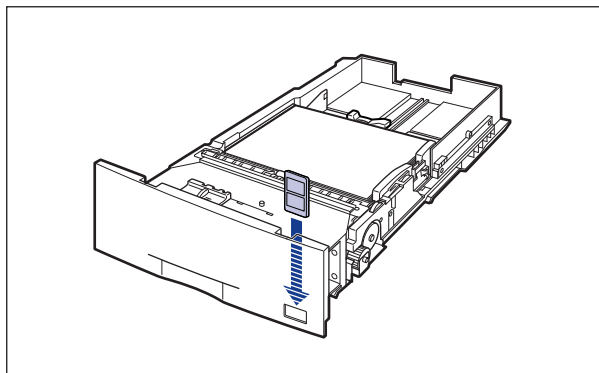

8 Hold the tab of the paper size setting switch, and align the paper size with the triangular mark of the paper size setting switch

The default is "A3".

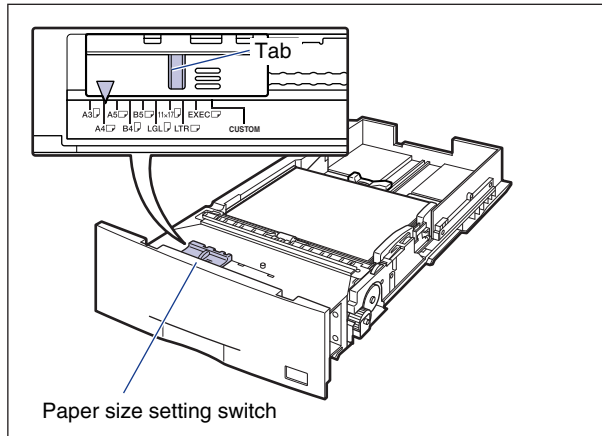

IMPORTANT

Make sure that the size of the loaded paper matches that of the paper size setting switch before setting the paper cassette in the printer. If the size indicated by the paper size setting switch does not match, this may result in printer malfunction.

9 Set the paper cassette in the paper feeder.

While holding the paper cassette with both hands, push it to the position shown in the figure ①. Then, hold the front of the paper cassette with your right hand and push it until it stops ②.

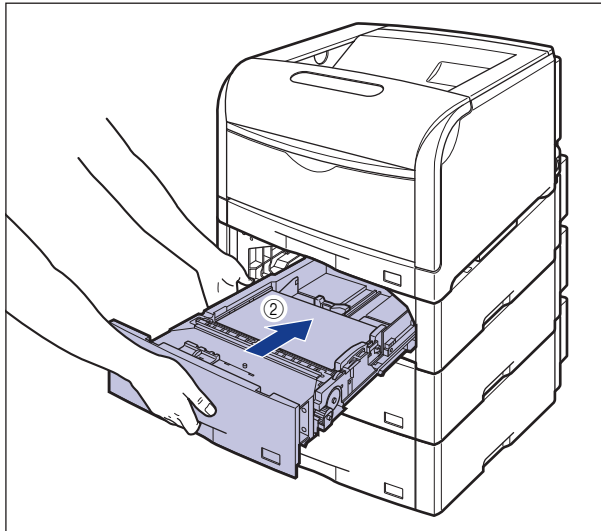
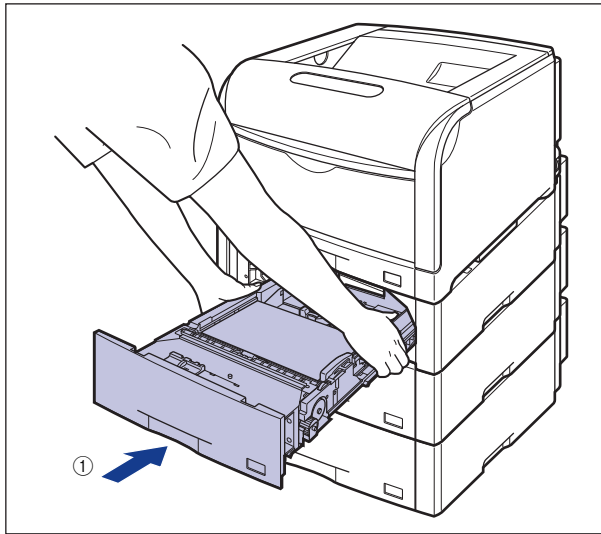

After lifting the front of the paper cassette up a little ③, push the paper cassette into the printer firmly until the front side of the paper cassette is flush with the front surface of the paper feeder ④.

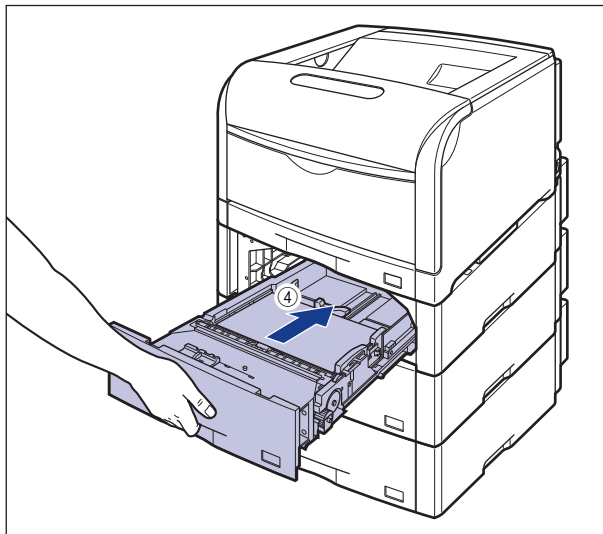
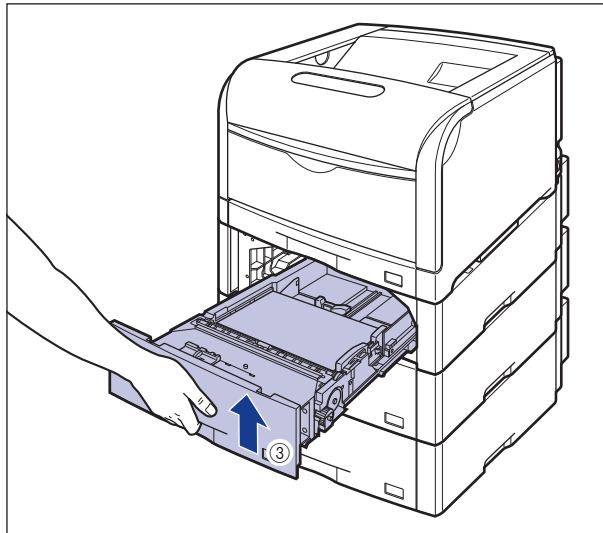

CAUTION

When setting the paper cassette to the paper feeder, be careful not to catch your fingers.

When Loading Custom Size Paper (Non-Standard Size Paper) in Cassette 2, 3, or 4



IMPORTANT

- The following size of custom paper can be loaded.
 - In case of portrait orientation: Width 210.0 - 297.0mm, Length 210.0 - 431.8mm
 - In case of landscape orientation: Width 210.0 - 297.0mm, Length 148.0 - 297.0mm
- When loading custom paper size in case of LBP5900SE, set <カセット N(N=2,3,4) ヨウシサイズ> as follows.
 - In case of landscape orientation: <ユーザセッテイサイズ>
 - In case of portrait orientation: <ユーザセッテイサイズ R>
- When changing orientation of custom paper size to be loaded frequently in case of LBP5900SE, it is convenient to set <カセット N(N=2,3,4) ヨウシサイズ> to <フリー>. It is not necessary to change the setting for <カセット N (N=2, 3, 4) ヨウシサイズ> each time to change orientation of the paper to be loaded. Observe the following guidelines when setting to <フリー>.
 - Be sure to check if the size of loaded paper matches the settings of the paper size in the printer driver before printing. If it differs, <41 ヨウシサイズ カクニン> message is displayed and the printer may stop the operation or may cause paper jams. Be sure to check if the size of loaded paper matches the settings of the paper size in the printer driver before printing. However, if setting <トクシユモードJ> to <ツカウ>, the printer operates without detecting the paper size regardless of difference between the paper size set in the printer driver and that of paper loaded in the paper cassette.
 - When printing with LIPS LX printer driver, the paper can be loaded in portrait or landscape orientation, but if printing custom paper of 297.0 mm long or less, load it in landscape orientation. Also, when not using LIPS LX printer driver, load the paper in portrait orientation.
- When loading custom paper size in case of LBP5600SE, set the feeding direction of loaded paper in [Feed Direction of Custom Paper Size] in [Cassettes Settings] dialog box in the Printer Status Window.

1 Pull the paper cassette out.

Pull the paper cassette out until it stops ①.

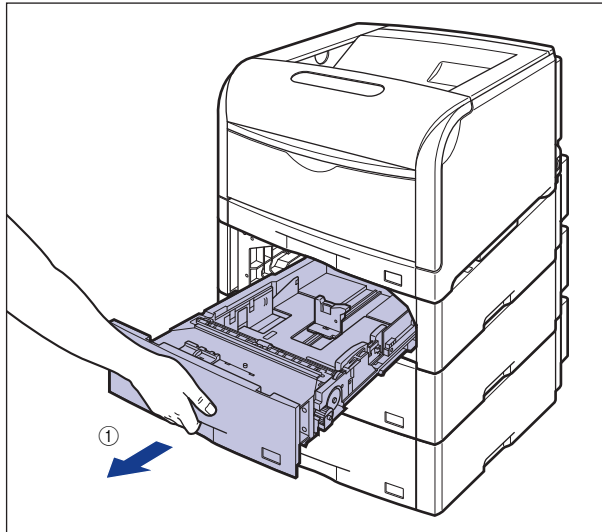

After lifting the front of the paper cassette up a little ②, pull it out with left hand holding until the tab on the right side of the paper cassette is shown completely ③.

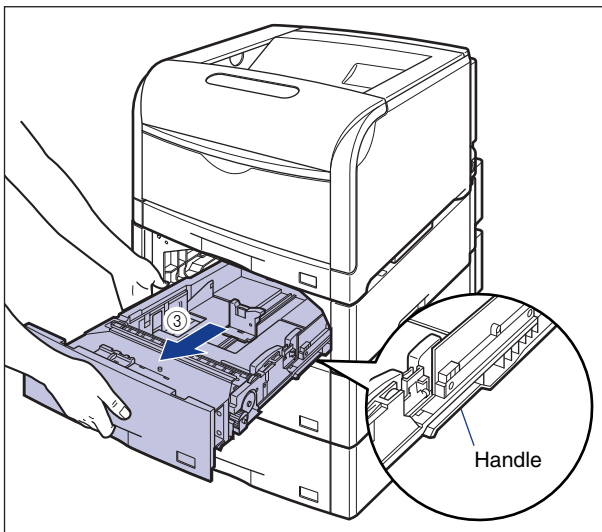
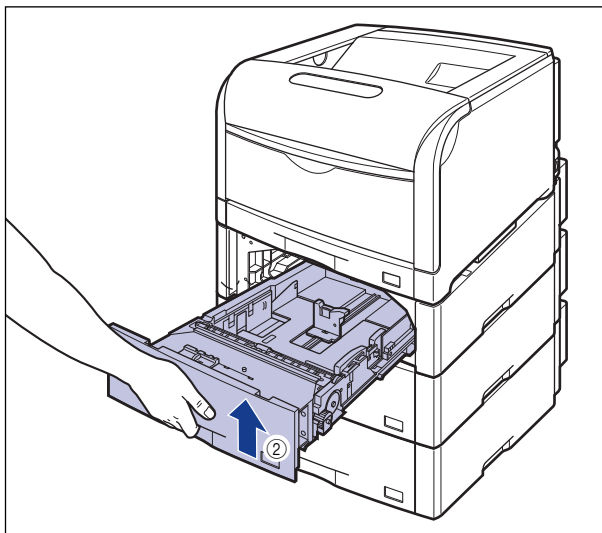

While holding the paper cassette with both hands, pull it out completely ④ as shown in the figure.

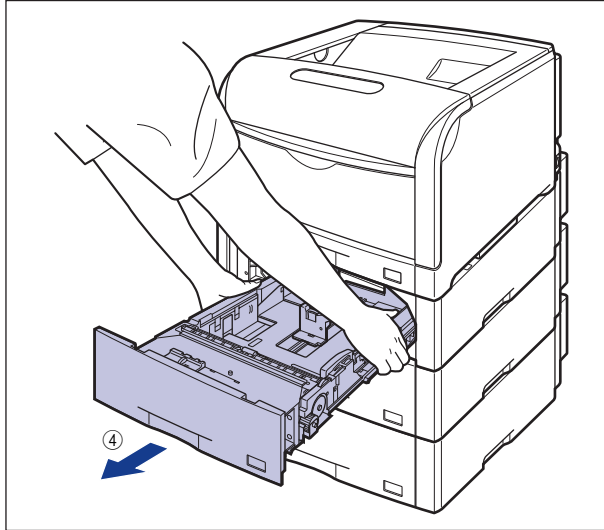

⚠ CAUTION

Be sure to take the paper cassette out of the paper feeder before loading paper. If paper is loaded while the paper cassette is partially pulled out, the paper cassette may drop or the printer may become damaged resulting in personal injury.

👤 IMPORTANT

- The paper cassette cannot be pulled out horizontally. If trying to pull it out forcefully, this may result in damage to the paper cassette.
- Because the paper cassette is heavy, hold it with your both hands securely.
- Place the removed paper cassette on an even and stable surface.

2 Load paper so that the edge of the paper is aligned with the front side of the paper cassette.

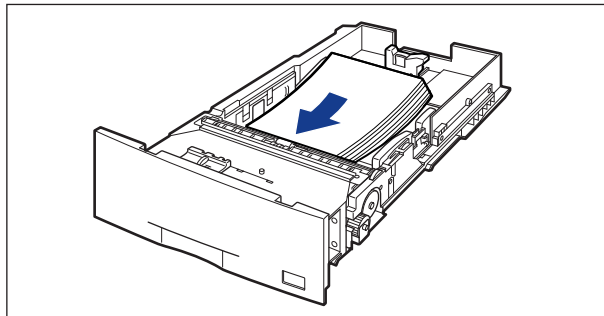

CAUTION

When loading paper, take care not to cut your hands with the edges of the paper.

IMPORTANT

If you use paper that has been poorly cut, multiple sheets of paper may be fed at once. In this case, align the edges of the stack on a hard, flat surface.

NOTE

- When using LBP5900SE and setting <カセットN(N=2,3,4) ヨウシサイズ> in キュウシ group of セットアップ menu to <フリー>, set due to your printer driver as follows in case of printing custom paper of 297.0 mm long or less.
When using LIPS LX printer driver: load the paper in landscape orientation
When not using LIPS LX printer driver: load the paper in portrait orientation
- When printing letterhead paper or paper printed with a logo, load the paper in the proper orientation according to the following instructions:
 - To print the paper in landscape orientation, load the paper so that the printing side is facing up, as shown in the following figures.

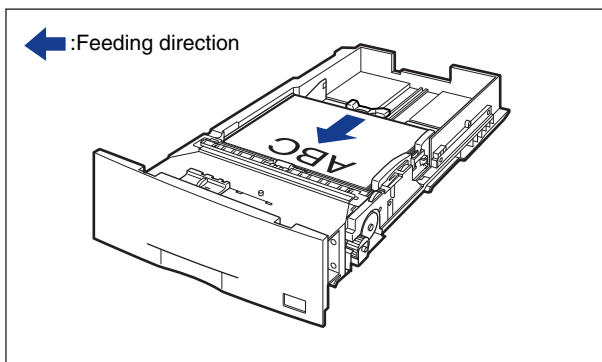
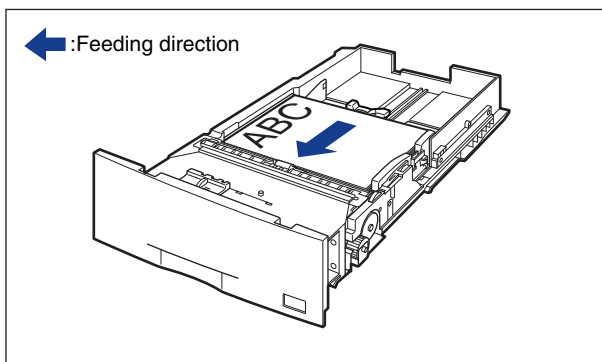

- When loading the paper in portrait orientation, load the paper so that the printing side is facing up, as shown in the following figures.

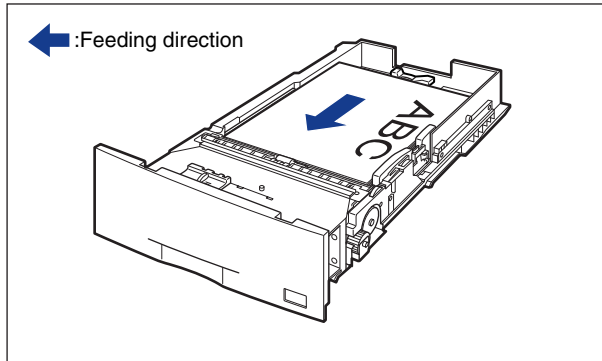
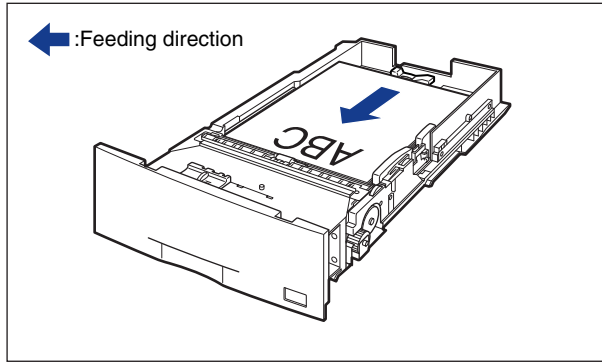

- 3** While holding the lock release lever of the rear paper guide, slide the guide to the mark for the size of the paper to be loaded.

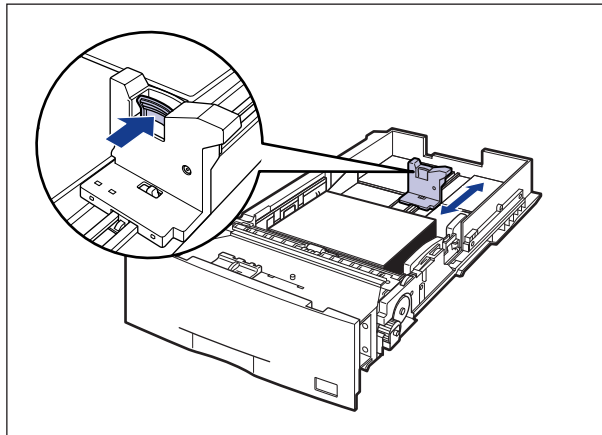

- 4** While holding the lock release lever of the side paper guide, slide the guide to the mark for the size of the paper to be loaded.

The side paper guides move together.

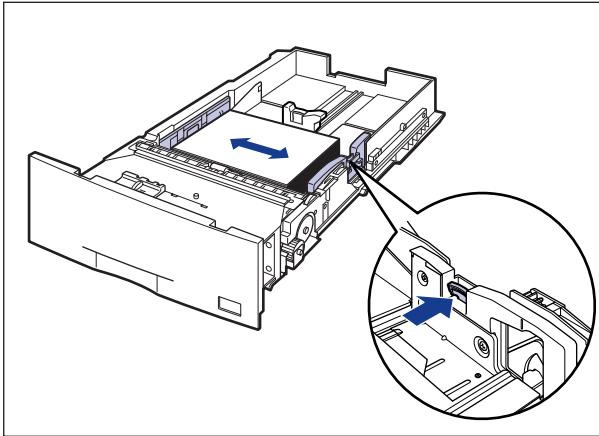

- 5** Press down the paper stack so that it is loaded under the hooks on the side paper guides.

Make sure that there is sufficient space between the hooks and paper stack. If there is no sufficient space, slightly reduce the amount of paper.

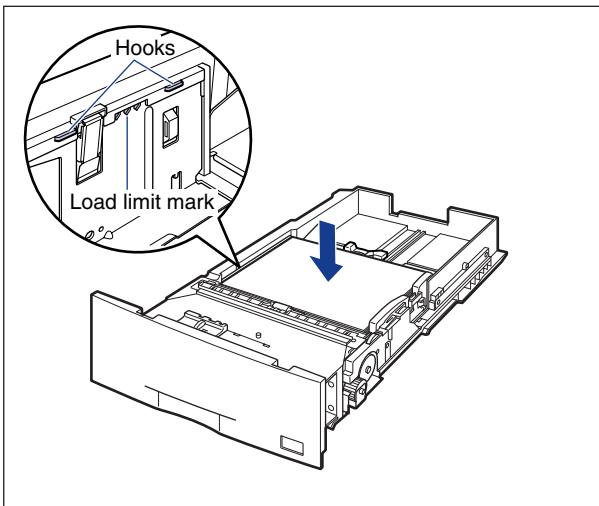

IMPORTANT

Up to approximately 550 sheets of plain paper (64 g/m²) can be loaded in the paper cassette. Be sure that the paper stack does not exceed the load limit marks on the paper guides. If the paper stack exceeds the load limit marks, this may result in misfeeds.

6 Hold the tab of the paper size setting switch, and align the triangular mark of the paper size setting switch with "CUSTOM"

The default is "A3".

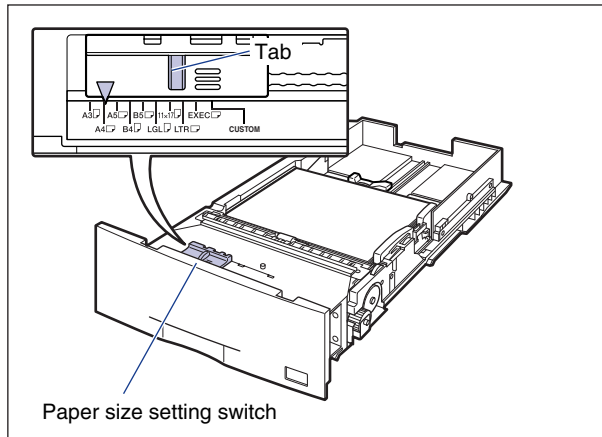

IMPORTANT

Make sure that paper size setting switch matches "CUSTOM" before setting the paper cassette in the printer. If the size indicated by the paper size setting switch does not match, this may result in printer malfunction.

7 Set the paper cassette in the paper feeder.

While holding the paper cassette with both hands, push it to the position shown in the figure ①. Then, hold the front of the paper cassette with your right hand and push it until it stops ②.

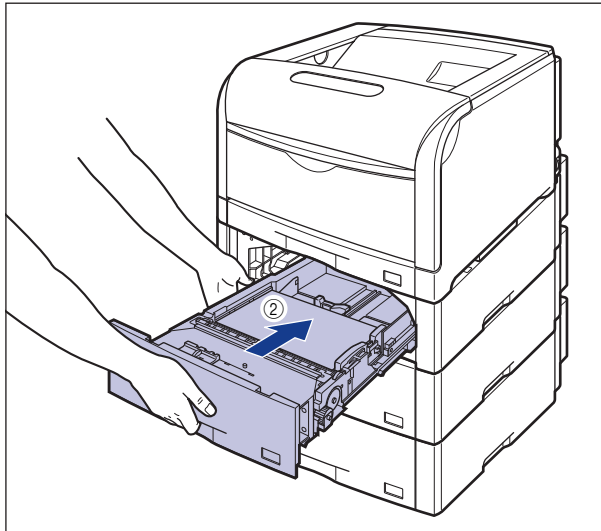
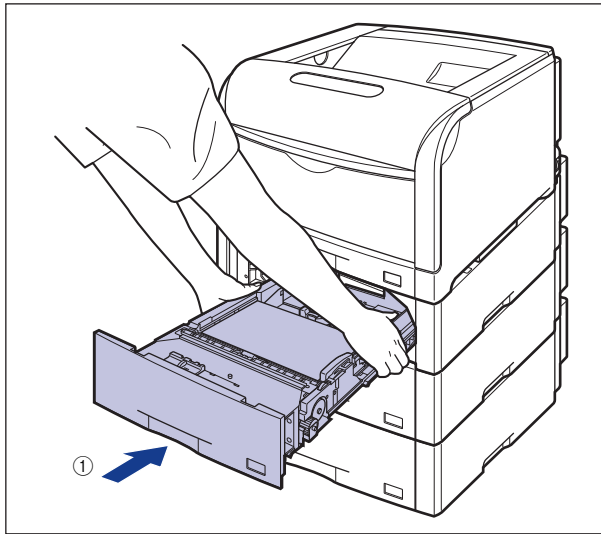

After lifting the front of the paper cassette up a little ③, push the paper cassette into the printer firmly until the front side of the paper cassette is flush with the front surface of the paper feeder ④.

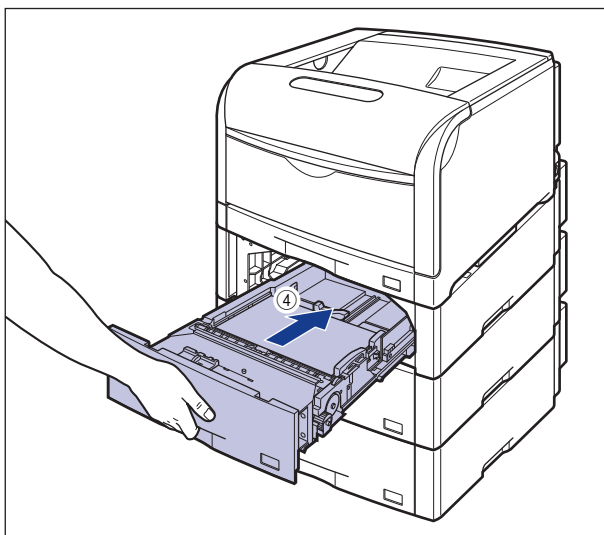
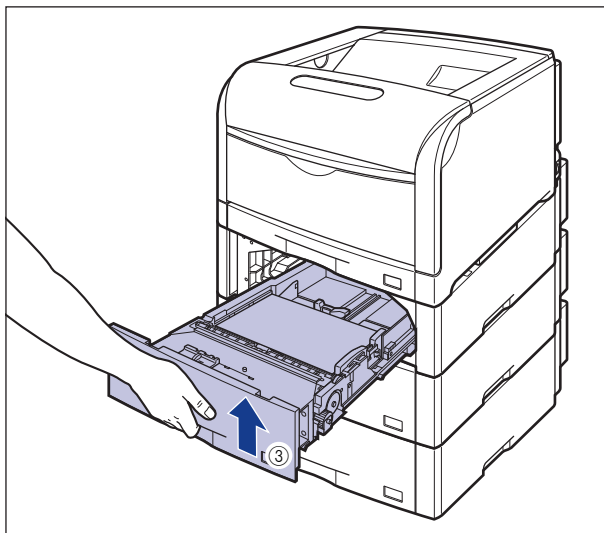

CAUTION

When setting the paper cassette to the paper feeder, be careful not to catch your fingers.

Loading Paper in the Multi-purpose Tray

When Loading Paper (Other than Postcards and Envelopes)

Use the following procedure to load plain paper, heavy paper, coated paper or label in the multi-purpose tray.

 **IMPORTANT**

Data cannot be printed within a 5mm margin on all sides of the paper. (If you have selected the [Print with Upper Left of Sheet as Starting Point] check box in the [Finishing Details] dialog box in the printer driver, however, you can extend the printable area to near the edges of the paper. For more details, see Online Help in the printer driver.)

1 Open the multi-purpose tray.

Hold the tab at the center of the printer, and open the multi-purpose tray.

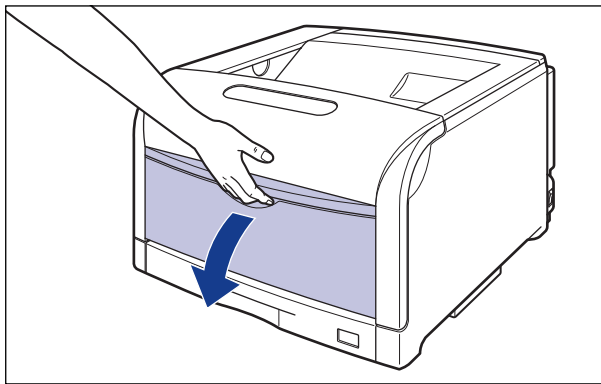

When loading the long size paper such as A3, B4, or long size paper, pull the auxiliary tray out ①, and open the extension tray ②.

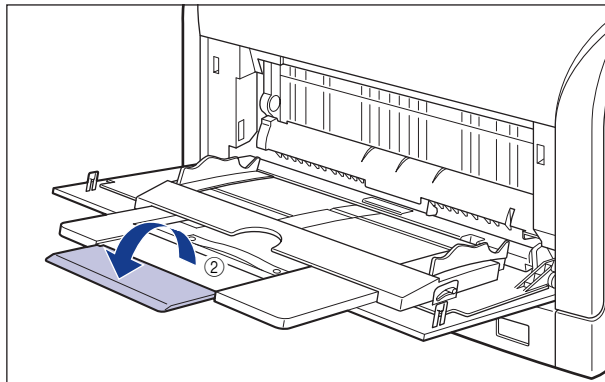
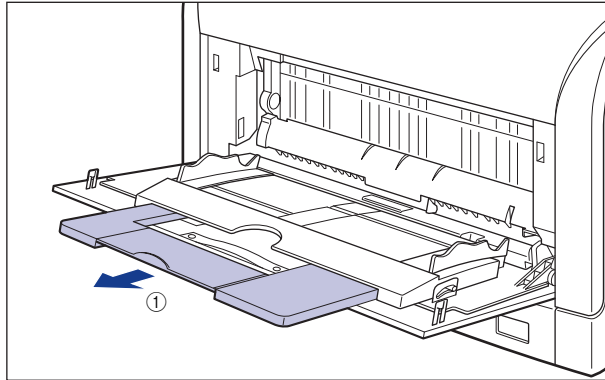

2 Spread the paper guides a little wider than the actual paper width.

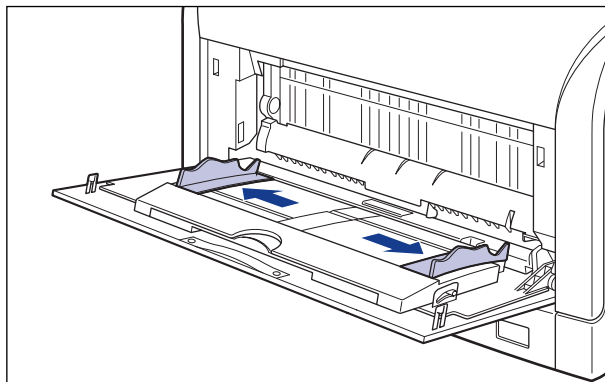

3 Before loading coated paper or labels, fan them in small batches and align the edges.

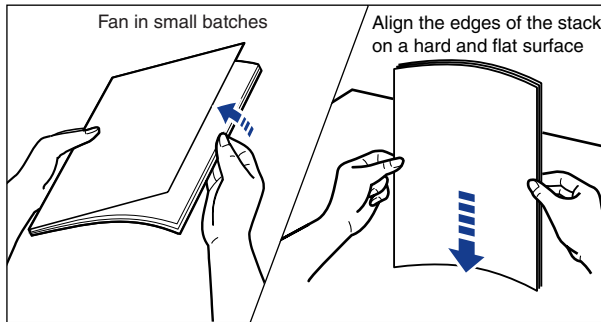

CAUTION

When loading paper, take care not to cut your hands with the edges of the paper.

IMPORTANT

- Be sure to fan the coated paper or labels thoroughly before loading them. If they are not fanned enough, multiple sheets of paper may be fed at once, causing paper jams.
- When fanning or aligning coated paper, try to hold the edges to avoid touching the printing surface.
- Take care not to mark or stain the printing surface of coated paper with fingerprints, dust, or oil. This may result in poor print quality.

4 Gently load the stack of paper with the printing side facing down until it touches the back of the tray.

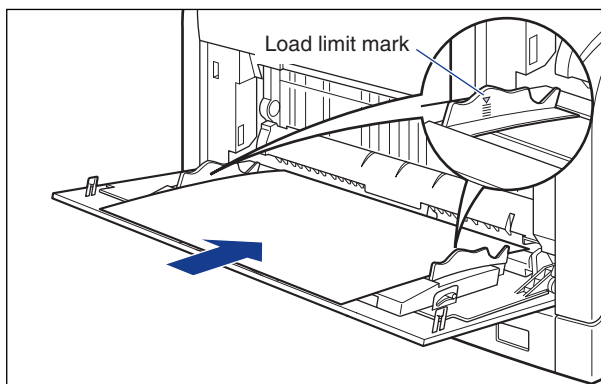

CAUTION

When loading paper, take care not to cut your hands with the edges of the paper.

IMPORTANT

When loading long size paper, set one piece at a time to the multi-purpose tray as shown in the figure.

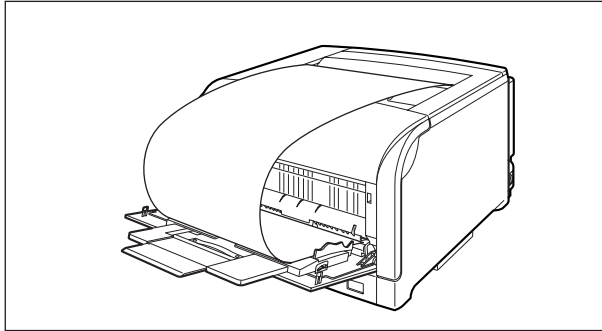

- The multi-purpose tray can be loaded with up to the number of sheets listed below. Make sure that the paper stack does not exceed the load limit marks.
 - Plain paper: Approx. 100 sheets (When plain paper that weighs 64 g/m² is used)
 - Heavy paper: Approx. 50 sheets (When heavy paper that weighs 128 g/m² is used)
 - Coated Paper: Approx. 50 sheets
 - Label: Approx. 40 sheets
- Load the paper so that it is straight.
- If the rear edge of the paper stack is not properly aligned, it may result in misfeeds or paper jams.
- If the paper is curled or folded at corners, flatten it before loading it in the printer.
- If you use paper that has been poorly cut, multiple sheets of paper may be fed at once. In this case, align the edges of the stack on a hard, flat surface.

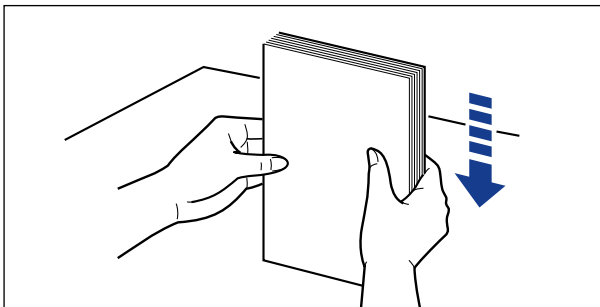

 NOTE

- When using LBP5900SE and setting <テザシトレイ ヨウシサイズ> in キュウシ group of セットアップ menu to <フリー>, set due to your printer driver as follows in case of printing custom paper of 297.0 mm long or less.
When using LIPS LX printer driver: load the paper in landscape orientation
When not using LIPS LX printer driver: load the paper in portrait orientation
- To print letterhead paper or paper printed with a logo, load the paper in the proper orientation according to the following instructions:
 - When loading paper in landscape orientation, such as when loading A4, B5, A5, Letter, or Executive size paper, load the paper so that the printing side is facing down and as shown in the following figures.

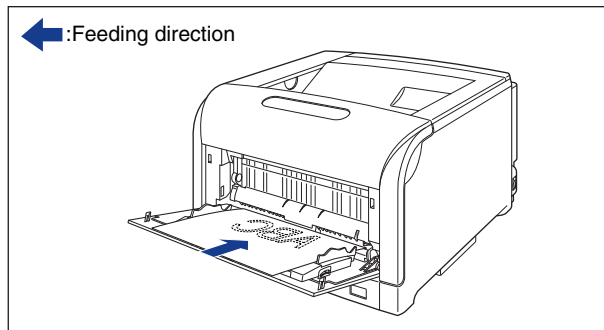
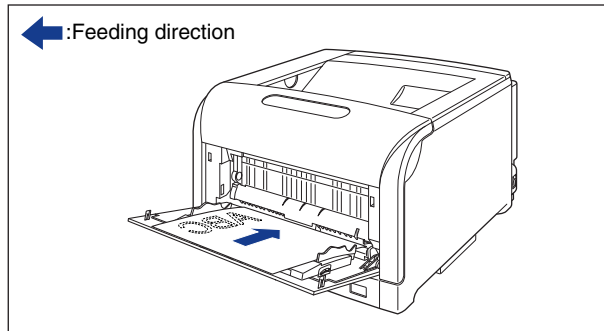

- When loading paper in portrait orientation, such as when loading A3, B4, 12 X 18, Ledger (11 X 17), or Legal size paper, load the paper so that the printing side is facing down and as shown in the following figures.

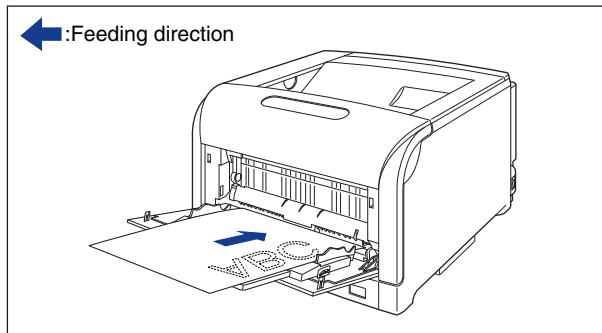
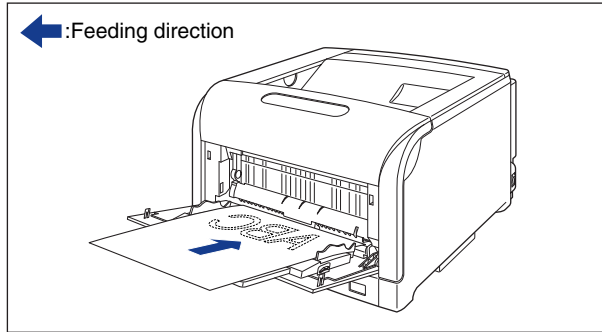

5 Align the paper guides with both sides of the stack.

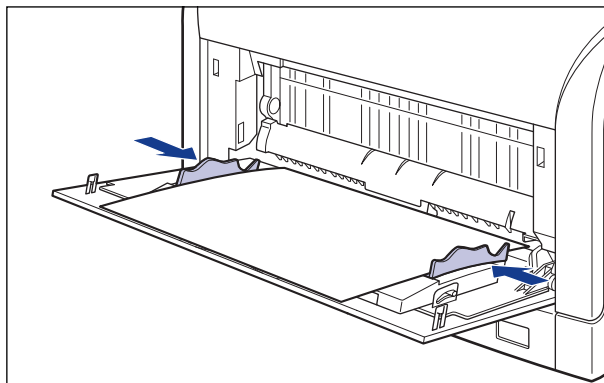

 **IMPORTANT**

- Be sure to align the paper guides with the width of the paper. If the paper guides are too loose or too tight, this may result in misfeeds or paper jams.

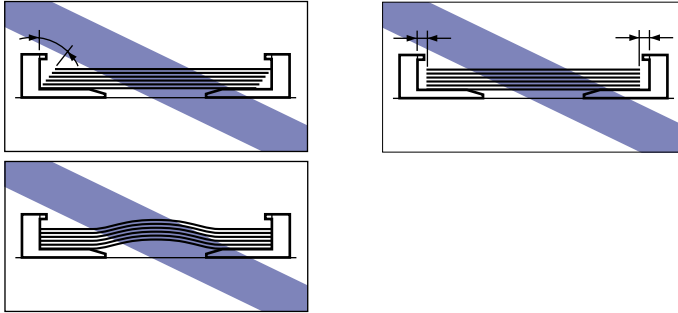

- Do not touch the paper in the multi-purpose tray or pull it out during printing. This may result in a faulty operation.

When Loading Postcards (Only for LBP5900SE)

Postcard, Reply postcard, 4 on 1 postcard and 4 on 1 postcard recommended by Canon can be loaded in the multi-purpose tray. Use the following procedure to load postcard in the multi-purpose tray.

 **IMPORTANT**

- When printing Postcard, Reply postcard, or 4 on 1 postcard, data cannot be printed within a 5mm margin on all sides of the paper. (If you have selected the [Print with Upper Left of Sheet as Starting Point] check box in the [Finishing Details] dialog box in the printer driver, however, you can extend the printable area to near the edges of the paper. For more details, see Online Help in the printer driver.)
- Be sure to use reply postcard that is not be creased.

 **NOTE**

This printer can print plain paper (64-105 g/m²) and heavy paper (106-169 g/m²) of postcard, Reply postcard, and 4 on 1 postcard. When printing plain paper or heavy paper of postcard, Reply post card, or 4 on 1 postcard, see "When Loading Paper (Other than Postcards and Envelopes)," on p. 60.

1 Open the multi-purpose tray.

Hold the tab at the center of the printer, and open the multi-purpose tray.

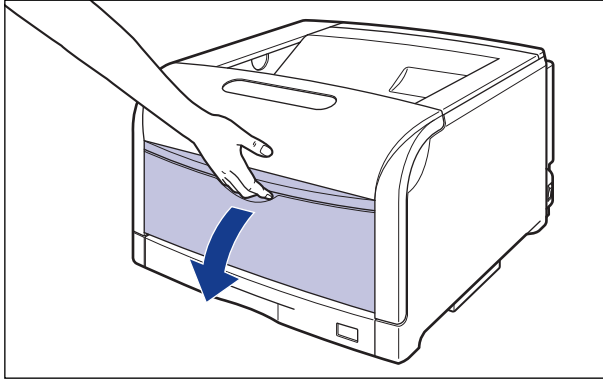

2 Spread the paper guides a little wider than the actual postcard width.

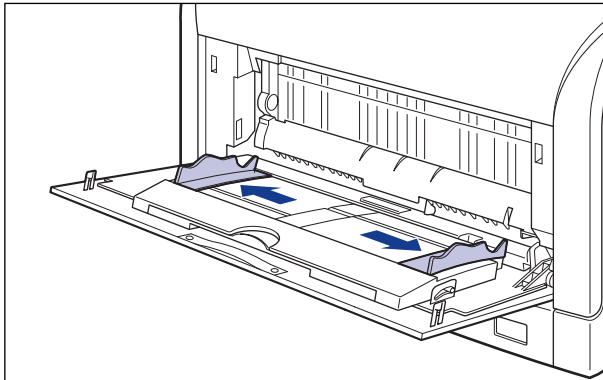

- 3** Gently load the stack of Postcard with the printing side facing down until it touches the back of the multi-purpose tray as shown in the figure.

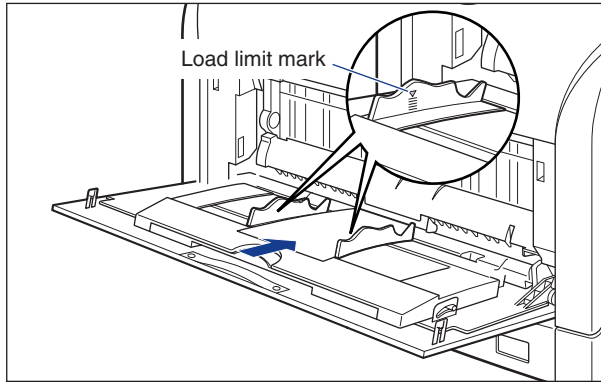

CAUTION

When loading paper, take care not to cut your hands with the edges of the paper.

IMPORTANT

- Up to approx. 40 sheets of Postcard, Reply postcard, or 4 on 1 postcard can be loaded in the multi-purpose tray. Make sure that the postcard stack does not exceed the load limit marks.
- When loading postcard, be sure to load it in portrait orientation so that the printing side is facing down and the top edge is toward the back of the printer when viewed from the front.

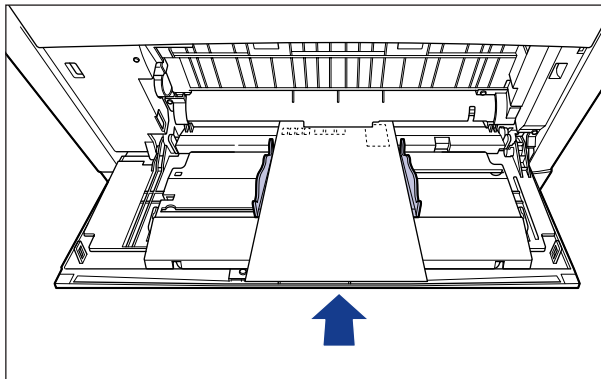

- When loading Reply postcard, be sure to load them in landscape orientation so that the printing side is facing down and the top edge is toward the back of the printer when viewed from the front.

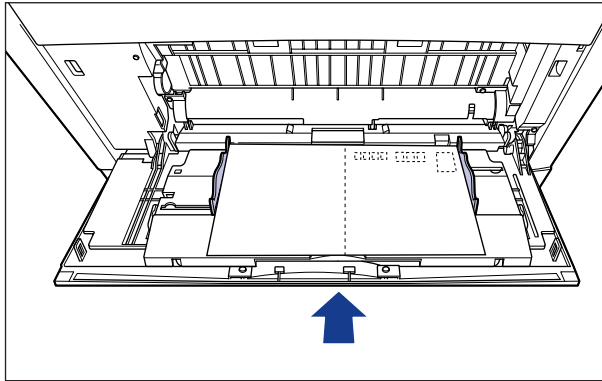

- When printing Reply postcard, match the paper settings and printing orientation specified in the application with actual printing orientation. (Example: In case of Windows NT 4.0 / 2000 / XP / Server 2003, Select [Double Japan Postcard Rotated].)
- When loading 4 on 1 postcard, be sure to load them in landscape orientation so that the printing side is facing down and the top edge is toward the left of the printer when viewed from the front.

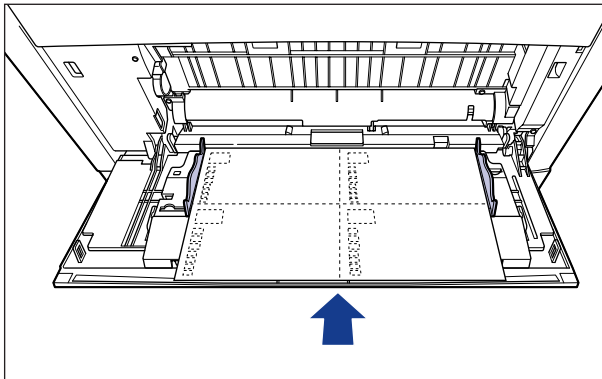

- If the postcard is curled, flatten the curls by warping it in the opposite direction before loading it.

- If using postcard that has been poorly cut, multiple sheets of paper may be fed at once. In this case, align the edges of the stack on a hard, flat surface.

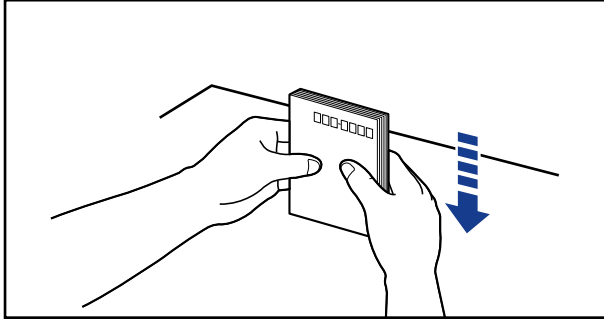

4 Align the paper guides with both sides of the stack.

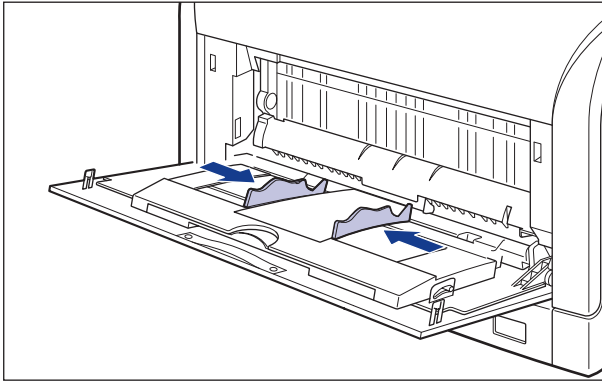

IMPORTANT

- Be sure to align the paper guides with the width of postcard. If the paper guides are too loose or too tight, this may result in misfeeds or paper jams.
- Do not touch the postcard in the multi-purpose tray or pull them out during printing. This may result in a faulty operation.

When Loading Envelopes

Envelopes can be loaded in the multi-purpose tray. Use the following procedure to load envelopes in the multi-purpose tray.



IMPORTANT

- The printable envelope types are shown below:
 - LBP5900SE

YOUGATA No.4
(105 mm x 235 mm)
(Envelope Y401 for Canon LBP
/recommended)

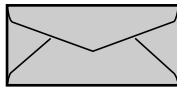

YOUGATA No.2
(114 mm x 162 mm)
(Envelope Y201 for Canon LBP/
recommended)

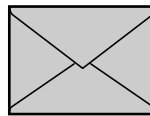

KAKUGATA No.2
(240 mm x 332 mm)

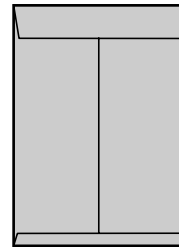

*Envelopes of YOUGATA No.4 and YOUGATA No.2
with a flap on the short edge cannot be used.

- LBP5600SE

Envelope DL
110.0 mm x 220.0 mm

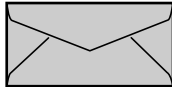

Envelope Monarch
98.0 mm x 191.0 mm

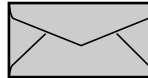

Envelope B5
176.0 mm x 250.0 mm



Envelope COM10
105.0 mm x 241.0 mm

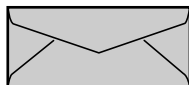

Envelope C5
162.0 mm x 229.0 mm

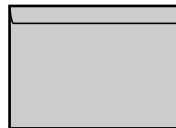

* You cannot use envelopes at sizes of DL, COM10, Monarch, and C5 that have a flap on the short edge.

- Do not use the envelopes with adhesive on the surface. This may result in poor print quality or damage to the printer.
- When printing envelopes, data cannot be printed within a 10mm margin on all sides of the envelopes. (If you have selected the [Print with Upper Left of Sheet as Starting Point] check box in the [Finishing Details] dialog box in the printer driver, however, you can extend the printable area to near the edges of the paper. For more details, see Online Help in the printer driver.)
- Printing speed drops when printing envelopes.



NOTE

When printing envelopes, they may be creased.

1 Open the multi-purpose tray.

Hold the tab at the center of the printer, and open the multi-purpose tray.

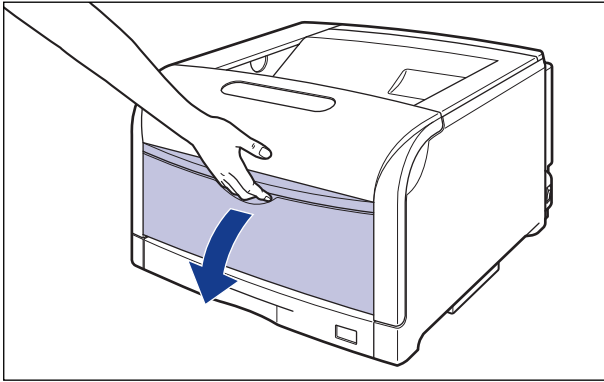

2 Spread the paper guides a little wider than the actual envelope width.

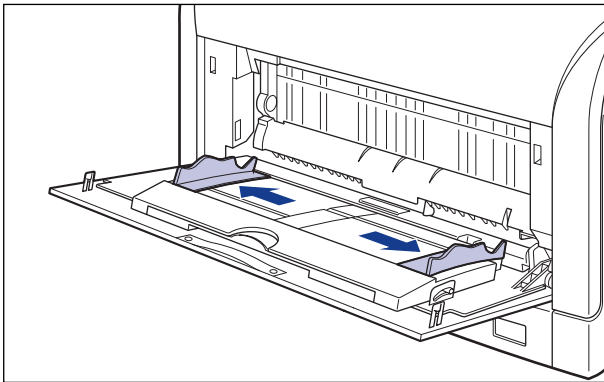

- 3** Place the stack of envelopes on a flat surface, flatten them to release any remaining air, and be sure that the edges are pressed tightly.

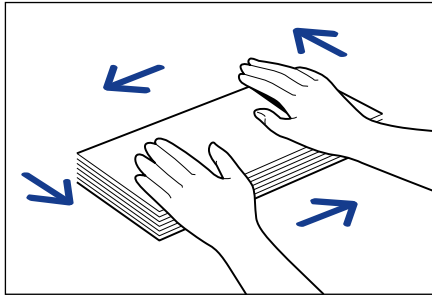

CAUTION

When loading paper, take care not to cut your hands with the edges of the paper.

- 4** Loosen any stiff corners of the envelopes and flatten curls as shown in the figure.

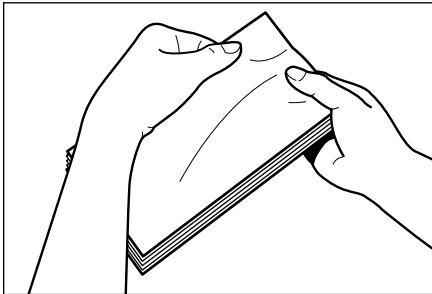

- 5** Align the edges of the envelopes on a flat surface.

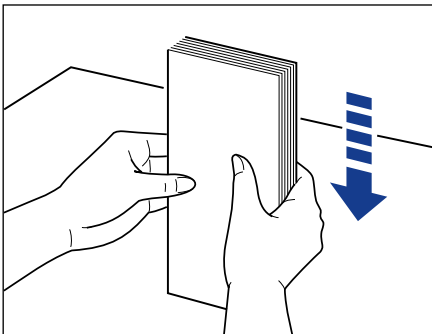

- 6** Gently load the stack of envelopes with the address side facing down and with the flaps closed and on the left side, until it touches the back of the multi-purpose tray as shown in the figure.

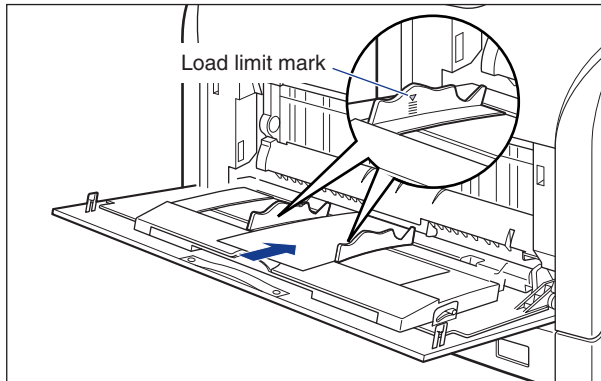

IMPORTANT

- Up to 10 envelopes can be loaded in the multi-purpose tray. Make sure that the envelope stack does not exceed the load limit marks.
- You cannot print on the reverse side (glued side) of envelopes.
- When loading YOUGATA No.4, YOUGATA No.2 (in case of LBP5900SE), DL, COM10, C5 or Monarch (in case of LBP5600SE), load them so that the flap is toward the left of the printer when viewed from the front.

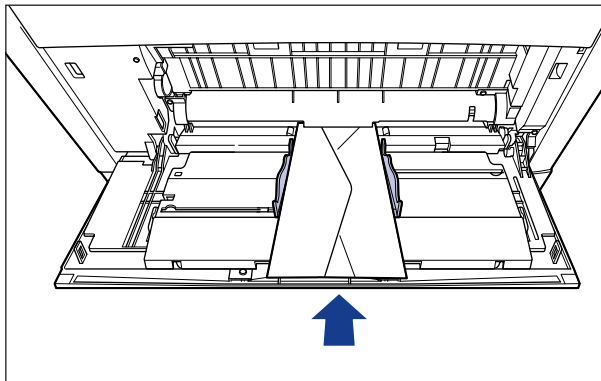

- When loading envelopes at size of KAKUGATA No.2 (in case of LBP5900SE), leave the flaps open and load them so that the bottom of the envelopes is toward the back of the printer when viewed from the front.

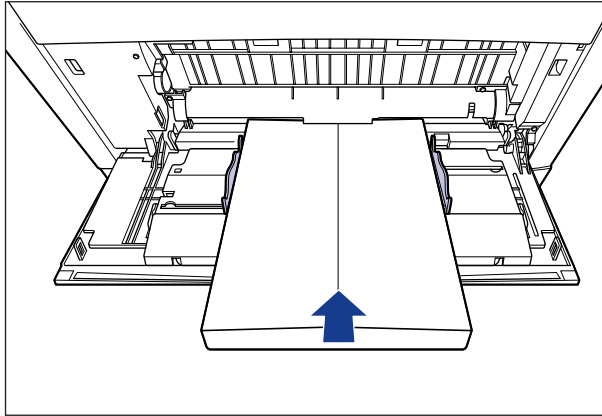

- When loading envelopes at size of Envelope B5 (in case of LBP5600SE), close the flaps and load them so that the bottom of the envelopes is toward the front of the printer when viewed from the front.

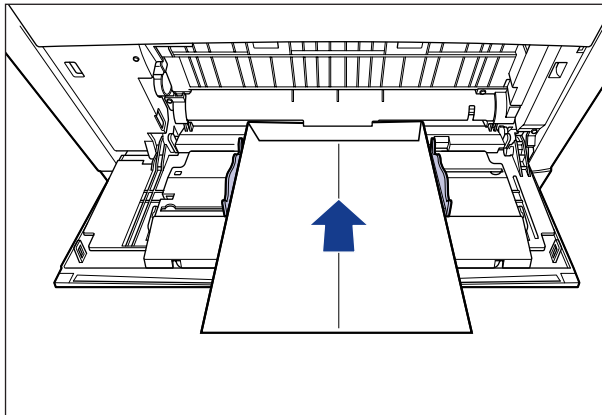

7 Align the paper guides with both sides of the stack.

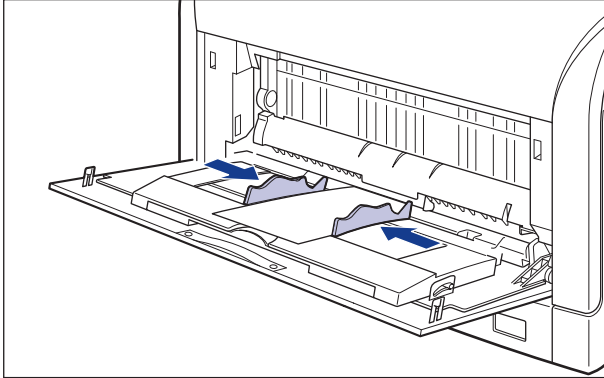

IMPORTANT

- Make sure that there is no space between the paper guides and the envelopes, and be careful not to press the envelopes so hard that they are distorted. They may result in misfeeds or paper jams.
- Do not touch the envelopes in the multi-purpose tray or pull them out during printing. This may result in a faulty operation.

Paper Jams

When a paper jam occurs during printing for some reason, in case of LBP 5900SE warning beep sounds and message <13 ヨウシガ ツマリマシタ > appears on display, while in case of LBP5600SE the following message is displayed on printer status window.

■ LBP5900SE



Display message	Paper jam position
<カセット1 エリア >	Cassette 1
<カセット2 エリア >	Cassette 2 (When the paper feeder is installed)
<カセット3 エリア >	Cassette 3 (When the paper feeder is installed)
<カセット4 エリア >	Cassette 4 (When the paper feeder is installed)
<マイカバー エリア >	Inside the front cover
<リョウメンユニット エリア >	Inside the front cover (Duplex print transport guide)

■ LBP5600SE

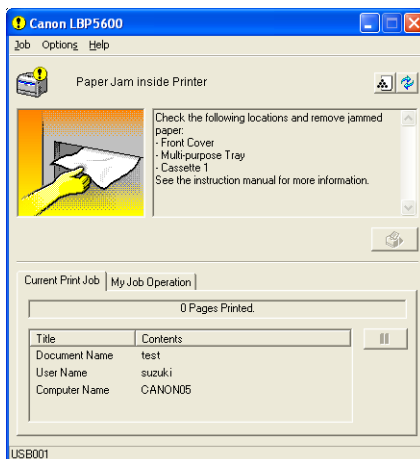

Procedure for Clearing Paper Jams

When a paper jam occurs, remove the jammed paper using the following procedure and resume a job. When the message that indicates the paper jam does not disappear, there is a possibility that torn pieces of paper are still left inside the printer. Inspect each part of the printer again, and completely remove all pieces of jammed paper.

WARNING

There are some areas inside the printer which are subject to high-voltages. When removing jammed paper or when inspecting the inside of the printer, do not allow necklaces, bracelets, or other metal objects to touch the inside of the printer. This may result in burns or electrical shock.

CAUTION

- The fixing unit and its surroundings inside the printer are hot during use. Make sure the fixing unit is completely cool before removing the jammed paper. Touching the fixing unit when it is still hot may result in burns.

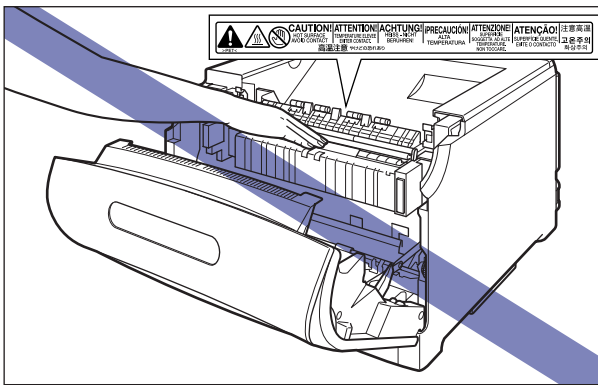

- When removing jammed paper, take care not to allow the toner to come into contact with your hands or clothing, as this will dirty your hands or clothing. If they become dirty, wash them immediately with cold water. Washing with warm water will set the toner and make it impossible to remove the toner stains.
- When removing paper jammed inside the printer, remove the jammed paper gently to prevent the toner on the paper from scattering. The toner may get into your eyes or mouth. If the toner gets into your eyes or mouth, wash them immediately with cold water and immediately consult a physician.
- When removing jammed paper, take care not to cut your hands with the edges of the paper.

IMPORTANT

- Remove jammed paper while the power of the printer is ON. If the power is turned OFF, the data being printed will be deleted.

- Applying excess force may result in tearing paper or damaging the parts in the printer. When removing jammed paper, pull the paper out in the most appropriate direction, judging from the position of the paper.
- If paper is torn, be sure to find and remove any remaining pieces of paper.
- The error message may remain if jammed paper is removed without opening the front cover. In this case, open and close the front cover once.
- Never touch the high-voltage contacts inside the front cover. This may result in damage to the printer.

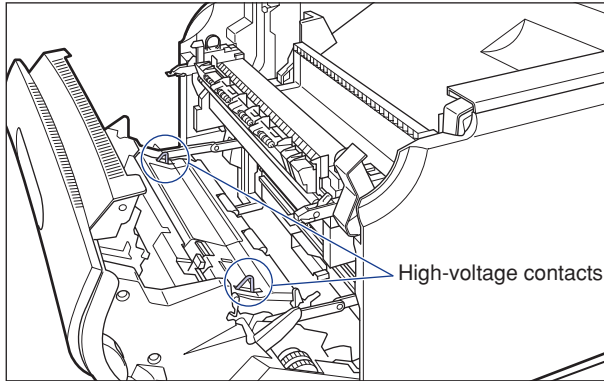

1 Check the output tray and remove any jammed paper.

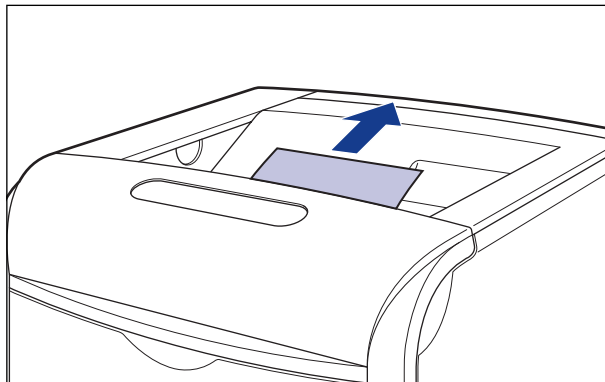

IMPORTANT

If the jammed paper cannot be removed easily, do not try to remove it forcefully but proceed to the next step.



NOTE

If the toner is on the removed paper, the dirt of the toner may be on the paper to be printed next.

- 2** If using the multi-purpose tray, remove any paper jammed in multi-purpose tray and close it.

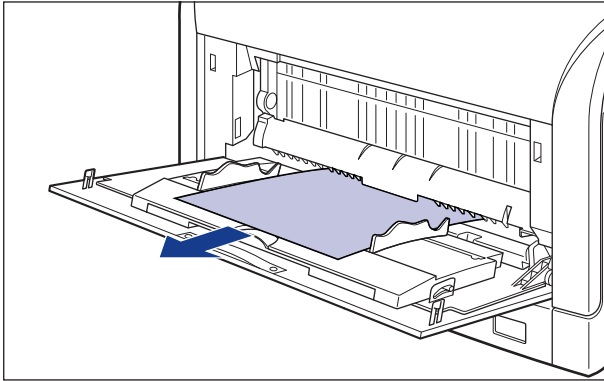

IMPORTANT

If the jammed paper cannot be removed easily, do not try to remove it forcefully but proceed to the next step.

- 3** Pull the paper cassette out.

Pull the paper cassette out until it stops ①.

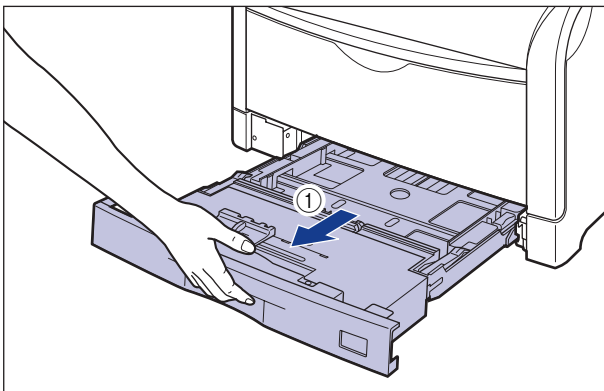

After lifting the paper cassette up a little ②, pull it out while supporting it with other hand as shown in the figure ③.

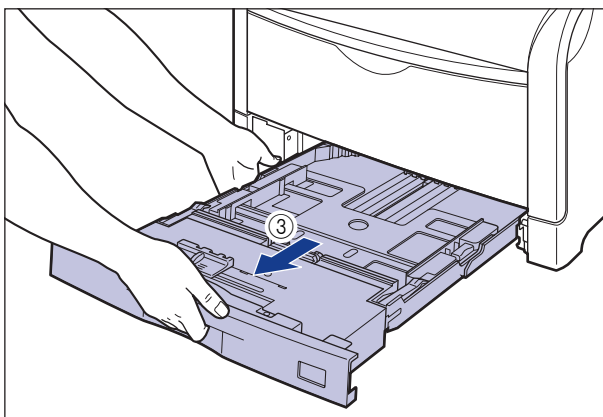
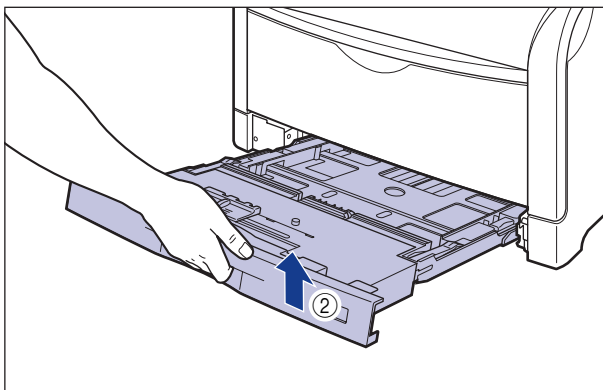

 **IMPORTANT**

The paper cassette cannot be pulled out horizontally. If trying to pull it out forcefully, this may result in damage to the paper cassette.

4 If the paper feeder is installed, pull all the paper cassettes out from the top.

Pull the paper cassette out until it stops ①.

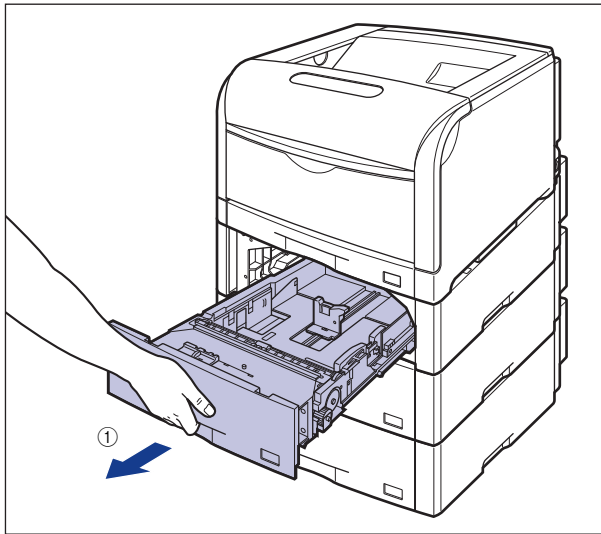

After lifting the paper cassette up a little ②, pull it out with left hand holding until the tab on the right side of the paper cassette is shown completely ③.

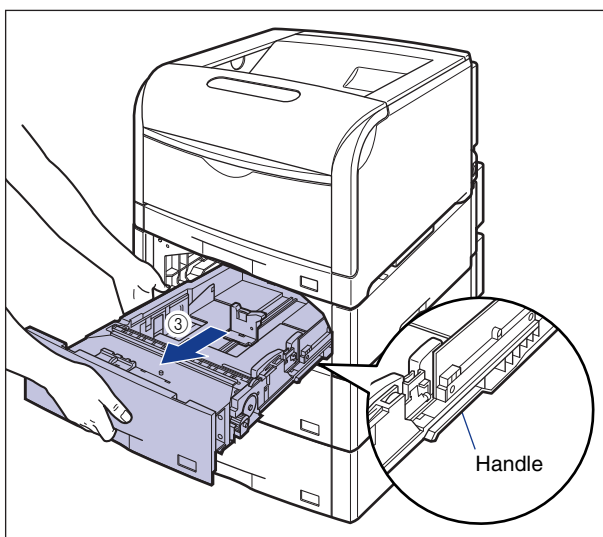
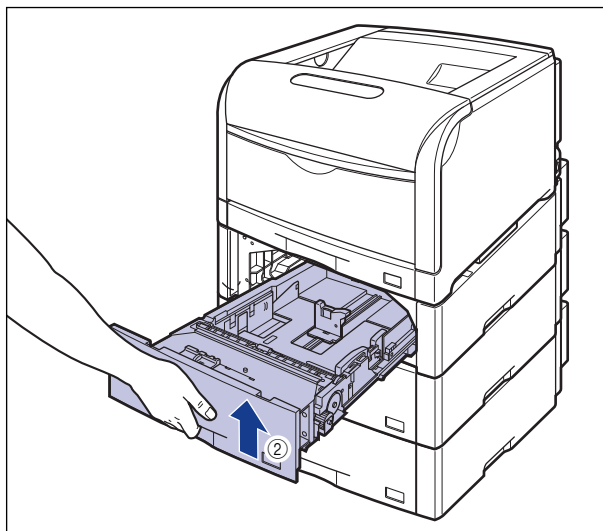

While holding the paper cassette with both hands, pull it out completely ④ as shown in the figure.

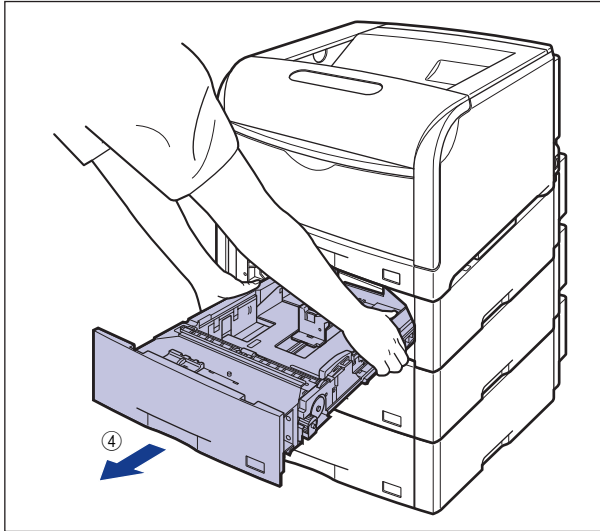

IMPORTANT

- Because the paper cassette is heavy, hold it with your both hands securely.
- Place the removed paper cassette on an even and stable surface.

5 Remove any jammed paper in the manner of pushing it downward.

In case of the printer

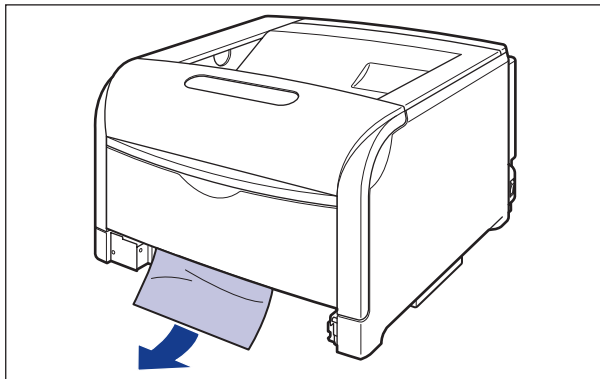

In case of the paper feeder

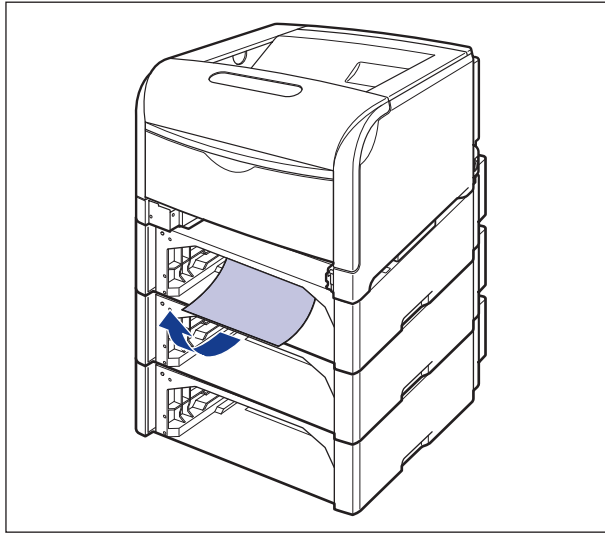

IMPORTANT

- If jammed paper cannot be removed easily, do not try to remove it forcefully but proceed to the next step.
- Do not touch the paper feed roller and switch on the lower portion of the printer. This may result in damage to the printer or printer error.

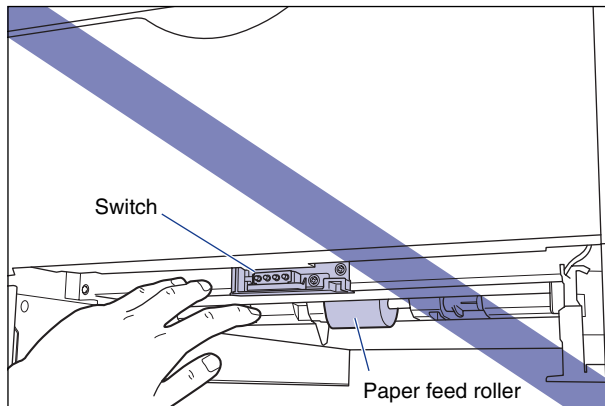

6 Open the front cover.

While pressing the lever on the right side of the front cover, open the front cover toward you.

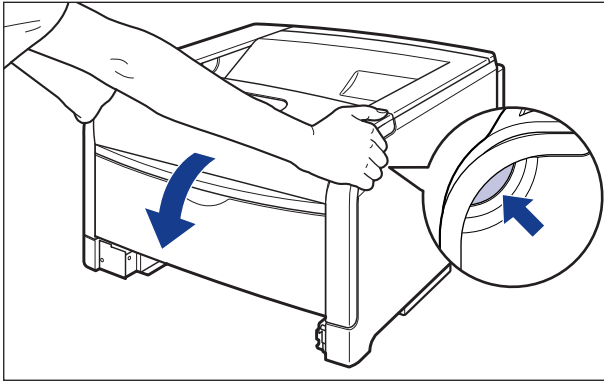

IMPORTANT

Before opening the front cover, make sure that the multi-purpose tray is closed.

7 Pull the fixing unit down toward you.

While pressing the green lock release buttons ① on the left and right side of the fixing unit, hold the tabs and pull the fixing unit down toward you ② as shown in the figure.

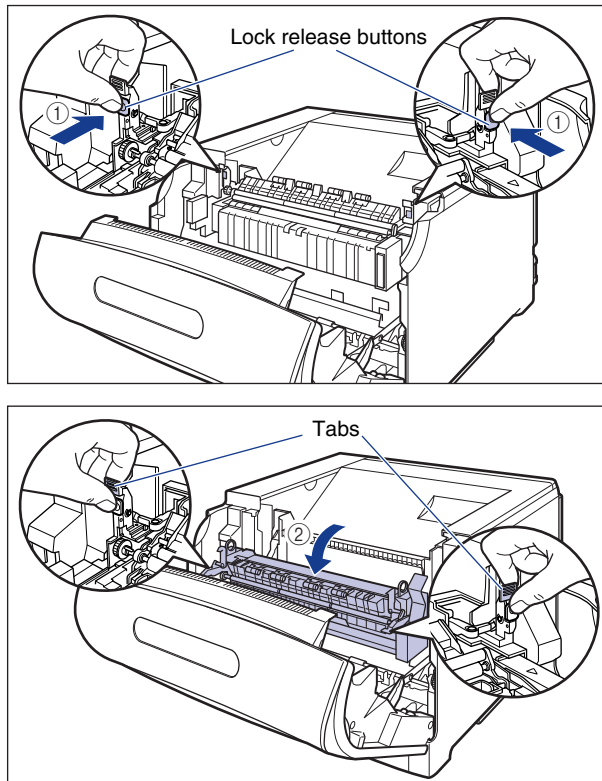

8 Remove jammed paper from the front of the fixing unit.

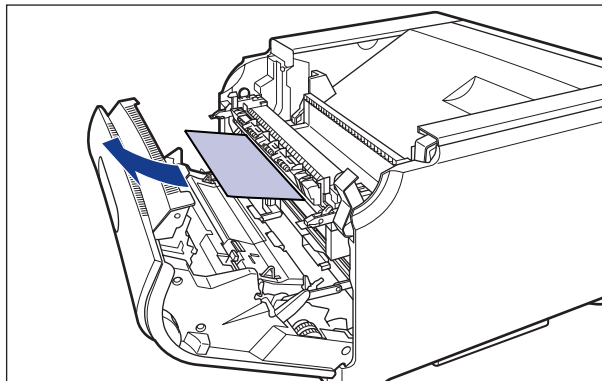

 **IMPORTANT**

If jammed paper cannot be removed easily, pull jammed paper out gently and strongly to remove it. If jammed paper still cannot be removed, do not try to remove it forcefully but proceed to the next step.

9 Remove jammed paper from the back of the fixing unit.

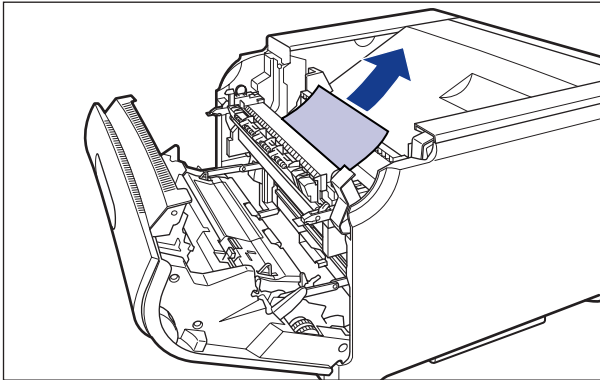

 **IMPORTANT**

Pull jammed paper out gently and strongly to prevent the toner that does not fix onto jammed paper from scattering,

- 10** While holding the tabs, move the fixing unit back to its original position ①, and then press the tabs on the both sides as shown in the figure ②.

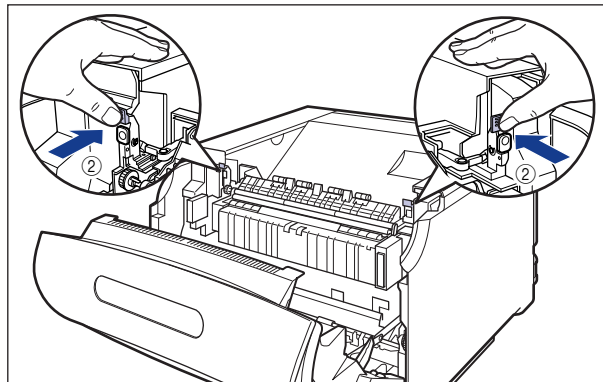
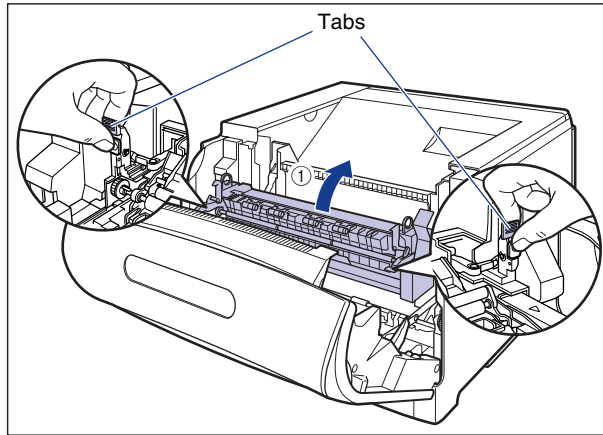

11 Remove jammed paper in the lower portion of the fixing unit.

Turn the dial on the left of the fixing unit in the direction of the arrow to send any jammed paper ① as shown in the figure.

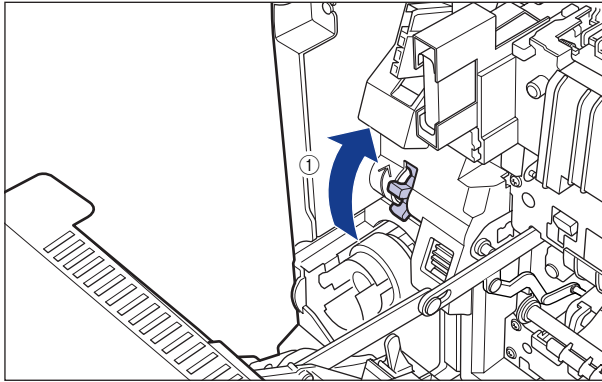

Remove any jammed paper as shown in the figure ②.

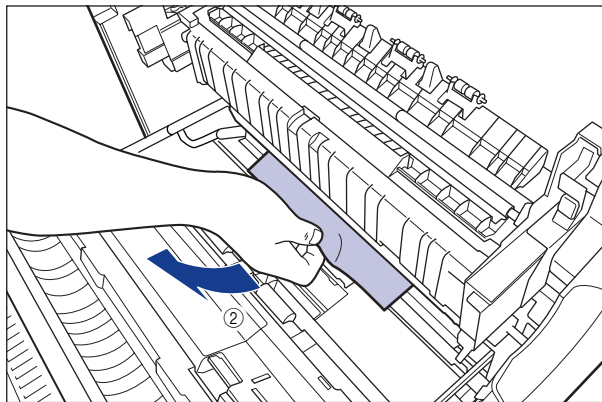

IMPORTANT

As the paper may be jammed in the back of the printer, turn the dial sufficiently to send the paper.

- 12** If a paper jam occurs when performing 2-sided printing, open the cover of the duplex print transport guide holding the tab inside the front cover as shown in the figure ①, and remove jammed paper ②.

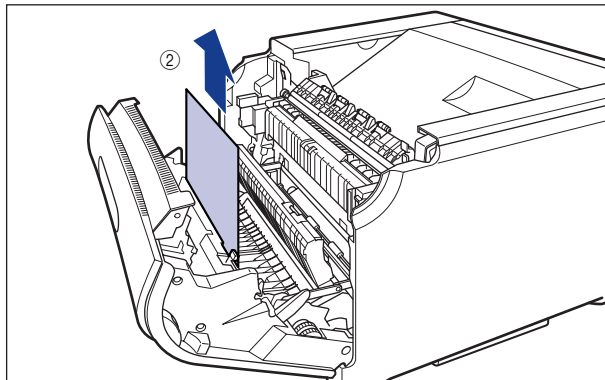
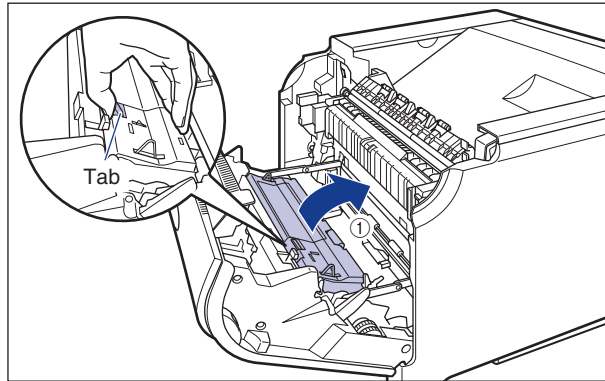

13 Close the front cover.

While supporting the front cover ①, push and close the front cover with both hands as shown in the figure ②.

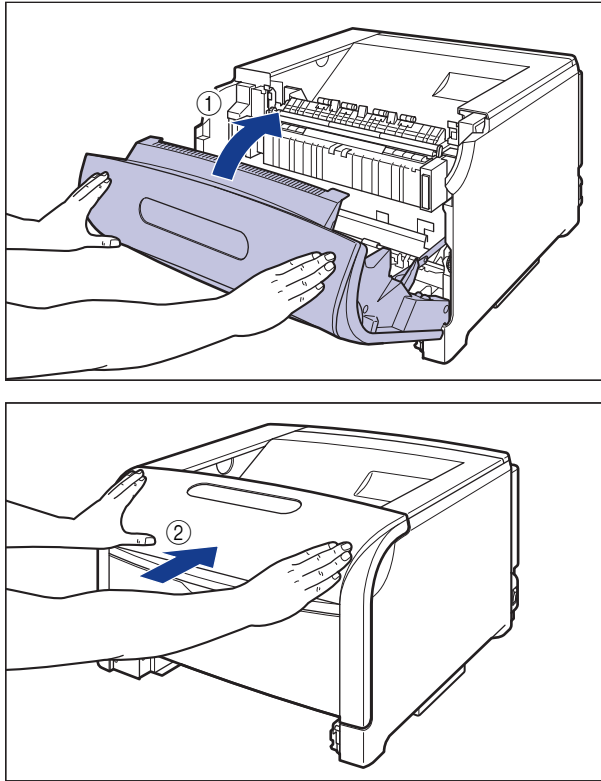

CAUTION

Push the front portion of the front cover to close it as shown in the figure. If closing the front cover by the levers on the both sides, you may catch your fingers, resulting in personal injury.

14 Set the paper cassette to the printer.

While holding the paper cassette with both hands and insert it until it stops ① as shown in the figure.

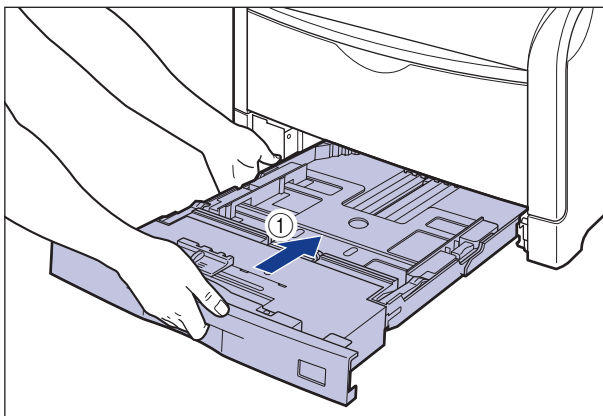

After lifting the front of the paper cassette up a little ②, push the paper cassette into the printer firmly until the front side of the paper cassette is flush with the front surface of the printer ③.

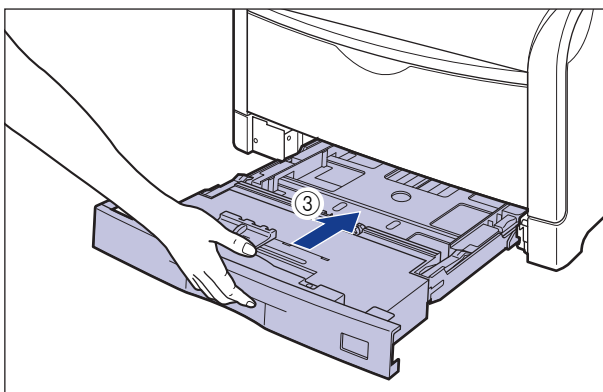
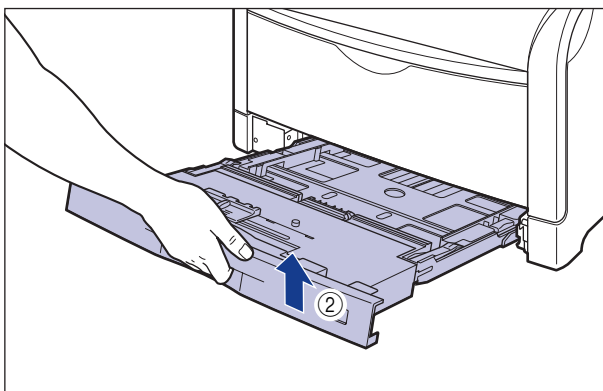

15 If the paper feeder is installed, set all the paper cassettes to the paper feeder from the top.

While holding the paper cassette with both hands, push it to the position shown in the figure ①. Then, hold the front of the paper cassette with your right hand and push it until it stops ②.

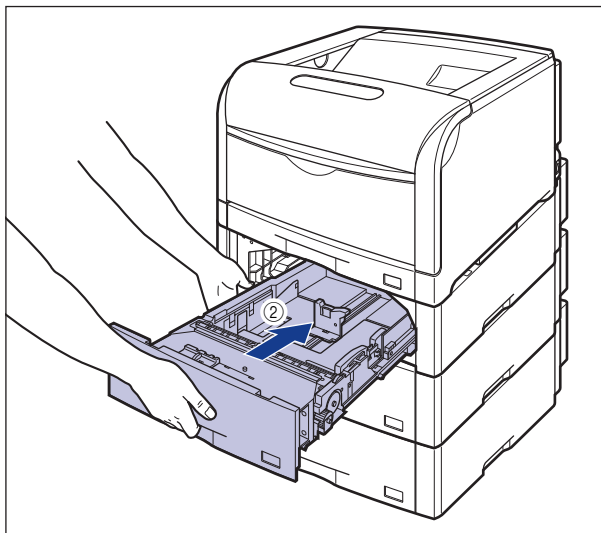
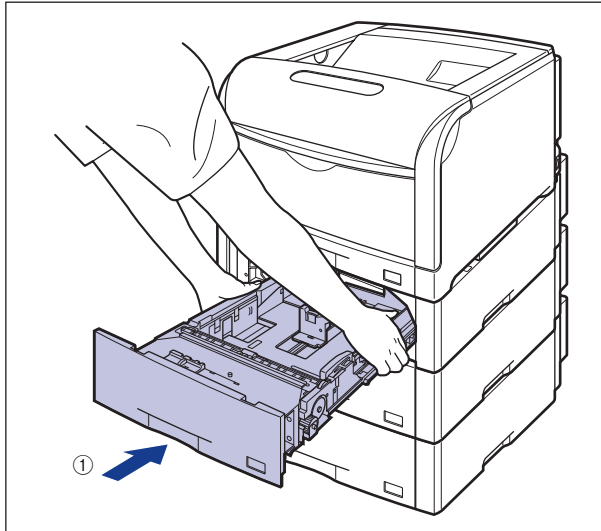

After lifting the front of the paper cassette up a little ③, push the paper cassette into the printer firmly until the front side of the paper cassette is flush with the front surface of the paper feeder ④.

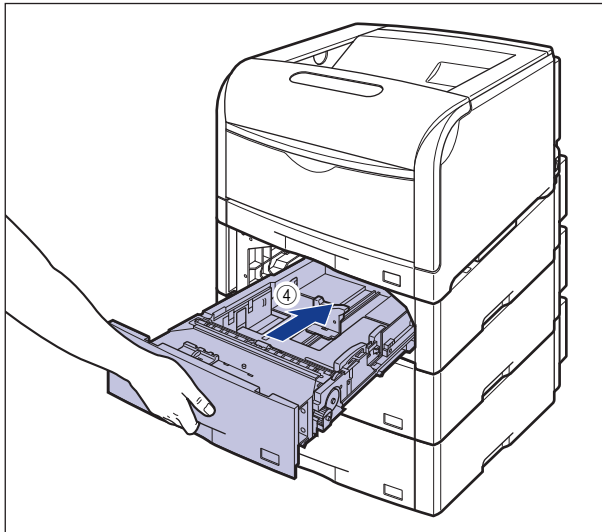
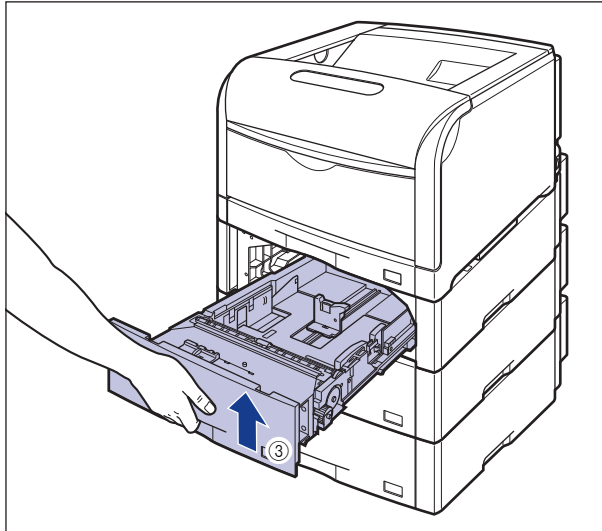

⚠ CAUTION

When setting the paper cassette to the paper feeder, be careful not to catch your fingers.

If the message that indicates the paper jam does not disappear even after removing the jammed paper following the procedure, there is a possibility that some paper still remains under the fixing unit. Following Step 12, turn the dial sufficiently to send the paper and remove it.

Replacing the Toner Cartridges

This section describes how to replace the toner cartridges.

When a Message Appears

Toner cartridges are consumable products. If getting almost out of toner when using the printer, a message appears on the display in case of LBP5900SE, or on the Printer Status Window in case of LBP5600SE, so follow the directions in the message.

■ LBP5900SE

Message	When it is Displayed	Contents and Remedies
<div style="border: 1px solid black; padding: 2px; display: inline-block;">16 X トナー ヨウイ</div> (X indicates K, Y, M, or C)	When the toner cartridge needs to be replaced soon.	<ul style="list-style-type: none"> - You can continue to print. - Have ready a new toner cartridge of the indicated color. - It is recommended that you replace the toner cartridge before printing a large amount of data.
<div style="border: 1px solid black; padding: 2px; display: inline-block;">16 X トナー コウカン</div> (X indicates K, Y, M, or C)	When the toner cartridge needs to be replaced soon.	<ul style="list-style-type: none"> - The printer stops printing. - When pressing [オンライン], you can continue to print. - Have ready a new toner cartridge of the indicated color. - It is recommended that you replace the toner cartridge before printing a large amount of data.
<div style="border: 1px solid black; padding: 2px; display: inline-block;">1G X トナー コウカン</div> (X indicates K, Y, M, or C)	When the toner cartridge has reached the end of its life.	<ul style="list-style-type: none"> - When <1G K トナー コウカン> appears, the printer stops printing, and you cannot continue to print. - When <1G X トナー コウカン> (X=Y, M, C) appears, you can print only in black and white. - Replace the toner cartridge of the indicated color with a new one.

* When getting almost out of toner, which message is displayed <16 X トナー ヨウイ> or <16 X トナー コウカン> depends on the setting of <ケイコクシヨリ> in セットアップ menu. The default value is <16 X トナー ヨウイ>.

* "K", "Y", "C", and "M" indicate black, yellow, cyan, and magenta respectively.

■ LBP5600SE

Message	When it is Displayed	Contents and Remedies
The <Toner Color>* toner cartridge needs to be replaced soon.	When the toner cartridge needs to be replaced soon.	<ul style="list-style-type: none"> - You can continue to print. - Have ready a new toner cartridge of the indicated color. - It is recommended that you replace the toner cartridge before printing a large amount of data.
Toner Cartridge Replacement Required The life of the toner cartridge has come to an end <Toner Colors>*. Replace the toner cartridge after opening the toner cover.	When the toner cartridge has reached the end of its life.	<ul style="list-style-type: none"> - When the black toner cartridge has reached the end of its life, the printer stops printing, and you cannot continue to print. - When any of the toner cartridges (other than black) has reached the end of its life, you can print only in black and white. - Replace the toner cartridge of the indicated color with a new one.

* Black, yellow, magenta, or cyan will appear in <Toner Color> (More than one color may appear.).



IMPORTANT

- When you are replacing a toner cartridge, be sure to use the toner cartridge designed for this printer.

Model Name	Supported Canon Genuine Toner Cartridge
LBP5900SE / 5600SE	Toner Cartridge 502 Black Toner Cartridge 502 Yellow Toner Cartridge 502 Magenta Toner Cartridge 502 Cyan

- If replacing the toner cartridges when <1G × トナー コウカン> (in case of LBP5900SE), or "Toner Cartridge Replacement Required" (in case of LBP5600SE) is not displayed, be sure to reset the counter of the toner cartridge (See p. 105).



NOTE

The lifetimes of the toner cartridges (Canon Genuine Parts) used in this printer are as follows. Page counts are for A4 at 5% page coverage with the print density set to the default setting. The level of the toner consumption varies depending on the type of the documents printed. If your average document contains a lot of graphics, tables, or charts, the life of the toner cartridge will be shorter as they consume more toner.

- Black (Toner Cartridge 502 Black): Approx. 10,000 pages
- Yellow (Toner Cartridge 502 Yellow): Approx. 6,000 pages
- Magenta (Toner Cartridge 502 Magenta): Approx. 6,000 pages
- Cyan (Toner Cartridge 502 Cyan): Approx. 6,000 pages

Replacing the Toner Cartridges

If a message appears, replace the toner cartridge of the indicated color with a new one.

WARNING

Do not throw a used toner cartridge into open flames, as this may cause the toner remaining inside the toner cartridge to ignite, resulting in burns or a fire.

CAUTION

Take care not to allow the toner to come into contact with your hands or clothing, as this will dirty your hands or clothing. If they become dirty, wash them immediately with cold water. Washing with warm water will set the toner and make it impossible to remove the toner stains.

IMPORTANT

Be sure to use only the toner cartridge designed for this printer.

NOTE

The packing materials may be changed in form or position to be placed, or may be added or removed without notice.

1 Open the toner cover.

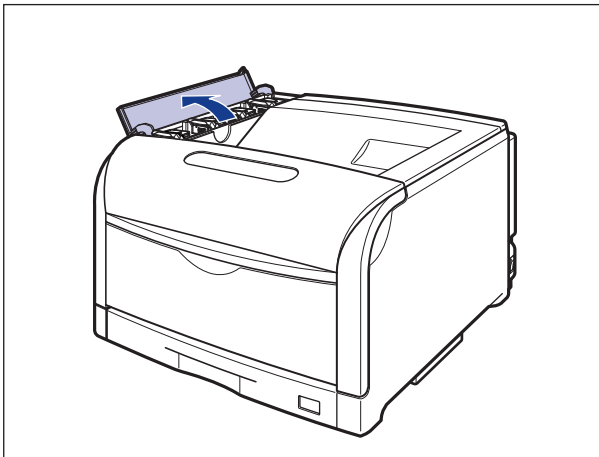

IMPORTANT

The toner cartridges are installed from the back in order of Yellow, Magenta, Cyan, and Black.

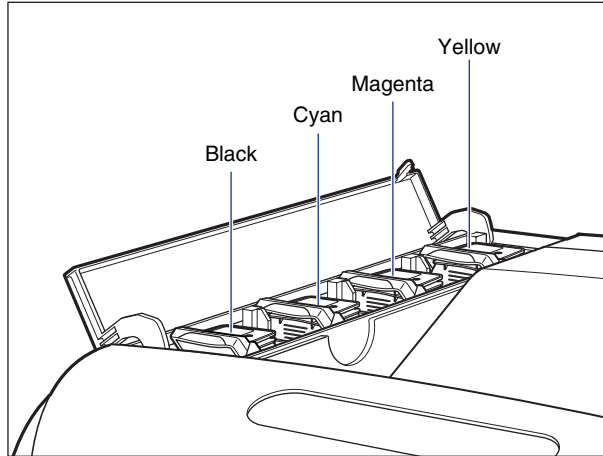

- 2** Tilt the lock release lever of the toner cartridge that you want to replace to the position of "⬅️", and release the lock.

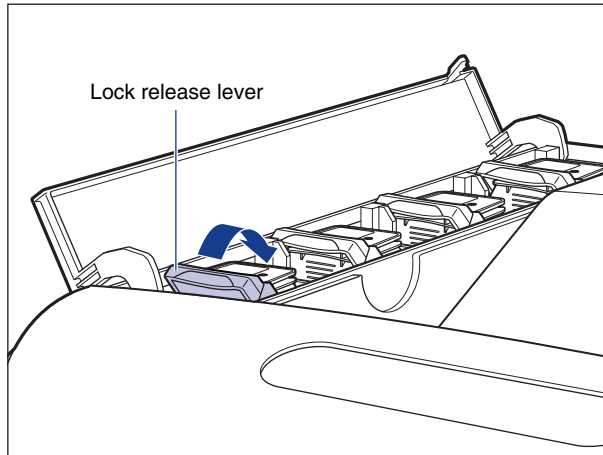

Align the circle mark on the lock release lever with that on the toner cartridge.

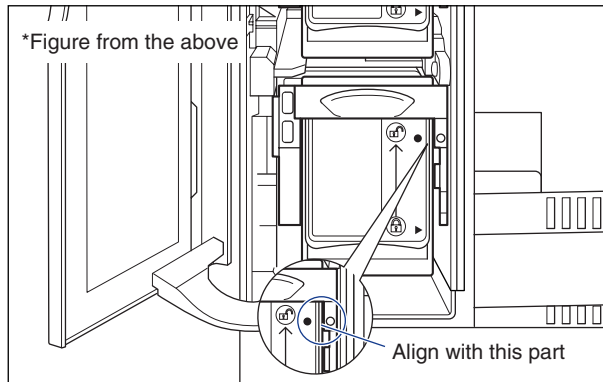

3 Remove the toner cartridge from the printer.

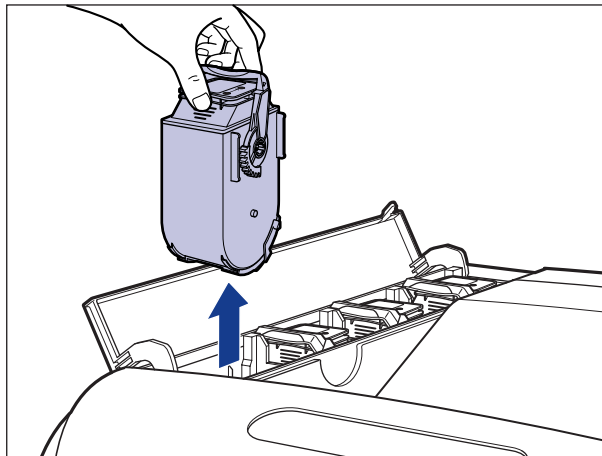

IMPORTANT

If the toner cartridge cannot be removed, check if the circle mark on the lock release lever is aligned with that on the toner cartridge. If you try to remove the toner cartridge forcefully, this may result in damage to the printer.

4 Take the toner cartridge out of the box, and then take it out of the protective pack.

While holding the center portion on the top of the protective pack, open it to left and right.

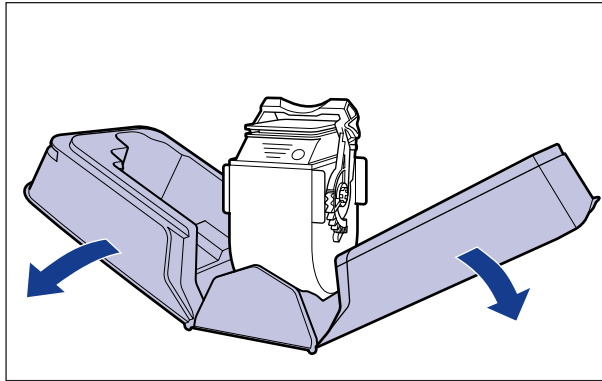

IMPORTANT

Keep the protective pack for the toner cartridge. It may be required after taking out the toner cartridge for printer maintenance.

5 Hold the toner cartridge so that the tab is at the bottom, and then shake it up and down 10 times each as shown in the figure to evenly distribute the toner inside the cartridge.

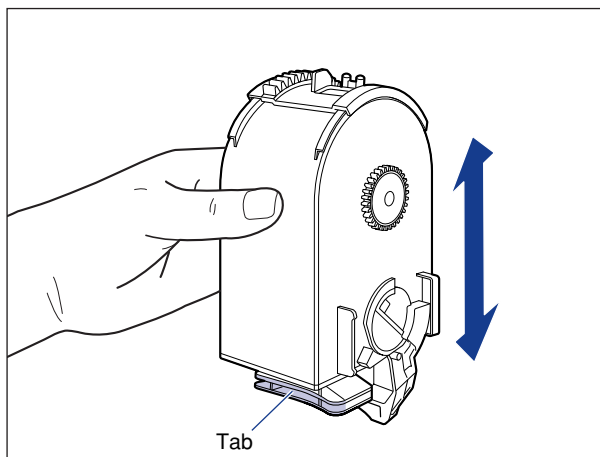

IMPORTANT

If toner is not distributed evenly, this may result in deterioration in print quality. Be sure to carry out this procedure properly.

- 6** While holding the tab, insert the toner cartridge into the printer ①, and then push it gently until it stops ② as shown in the figure.

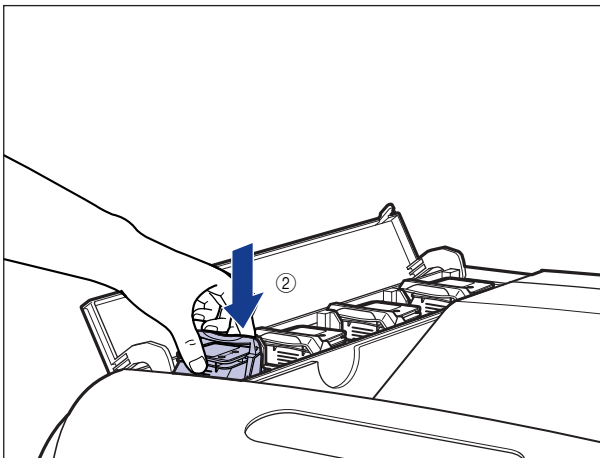
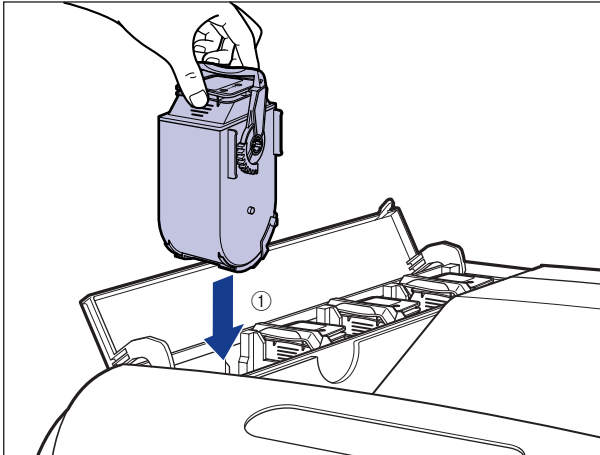

Insert the toner cartridge so that the orientation of the character on the toner cartridge and that on the toner cover match.

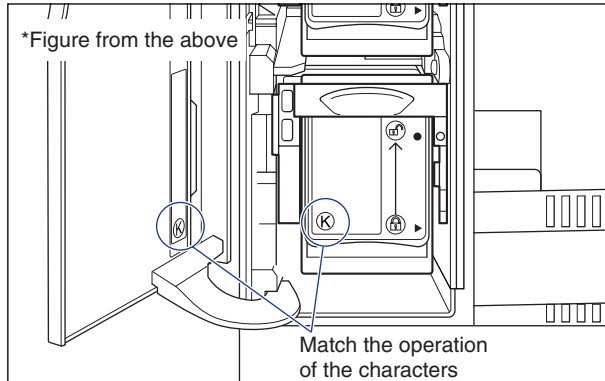

- 7** Tilt the lock release lever to the position of "Ⓚ", to lock the toner cartridge.

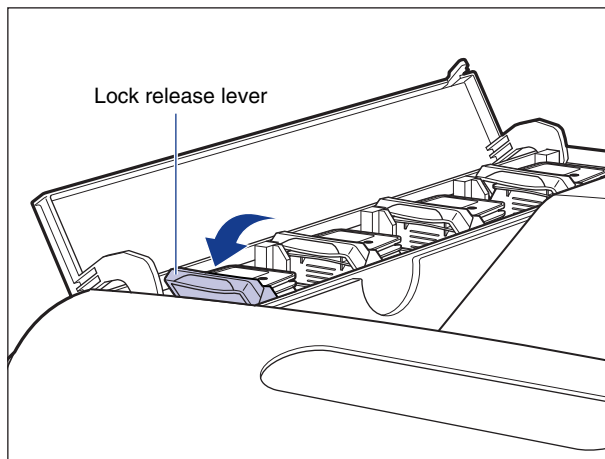

Align the triangular mark on the lock release lever with that on the toner cartridge.

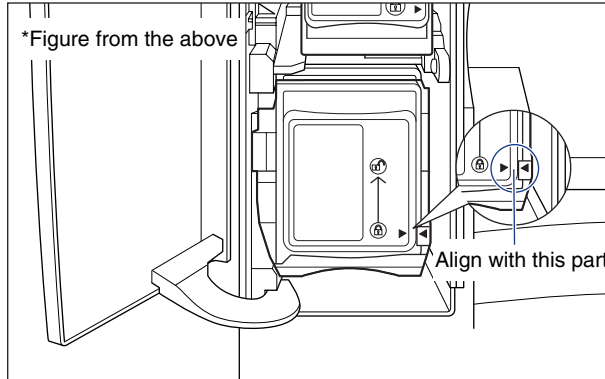

8 Close the toner cover.

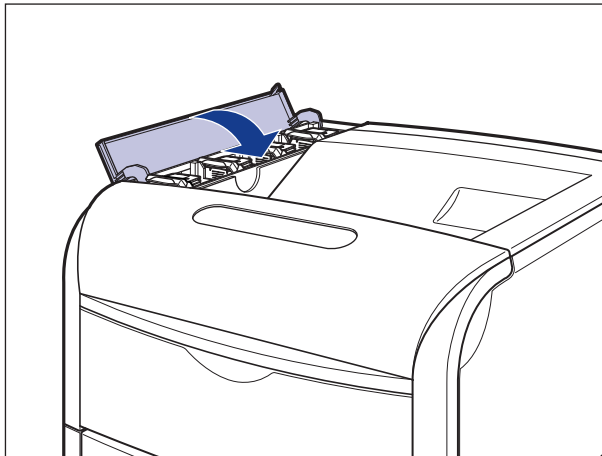

IMPORTANT

- If you cannot close the toner cover, check if the toner cartridges are installed properly. If you try to close the toner cover forcefully, this may result in damage to the printer or toner cartridges.
- Do not leave the toner cover open for a long time after installing the toner cartridge.

NOTE

After the installation of the toner cartridges, it takes a few seconds until the message <1G X トナー コウカン > (in case of LBP5900SE) or "Toner Cartridge Replacement Required" (in case of LBP5600SE) disappears. If the message does not disappear, remove the replaced toner cartridge, hold the toner cartridge so that its tab is at the bottom, shake the cartridge up and down forcefully again to evenly distribute the toner inside the cartridge, and then install the toner cartridge.

If you replace the toner cartridge when <1G X トナー コウカン> (in case of LBP5900SE), or "Toner Cartridge Replacement Required" (in case of LBP5600SE) was not being displayed, reset the counter in Resetting the Counter of Toner Cartridges (See p. 105).

Resetting the Counter of Toner Cartridges

If you replaced a toner cartridge when <1G X トナー コウカン> (in case of LBP5900SE), or "Toner Cartridge Replacement Required" (in case of LBP5600SE) was not being displayed, be sure to reset the counter using the following procedure. If you do not reset the counter, lifetime of the toner cartridge cannot be detected properly.



IMPORTANT

Carry out this procedure only after you replaced a toner cartridge when <1G X トナー コウカン> (in case of LBP5900SE), or "Toner Cartridge Replacement Required" (in case of LBP5600SE) was not being displayed.

In Case of LBP5900SE



1 Press [リセット].

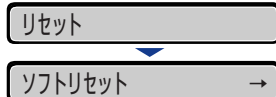

リセット menu is displayed.



2 With [◀] and [▶], select <トナー コウカン> and press [実行].

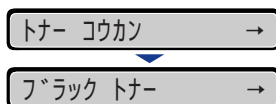

The color of the toner cartridge is displayed.



3 With [◀] and [▶], select the toner cartridge of the counter to be reset, and press [実行].

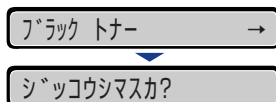

A confirmation message is displayed.



4 Press [実行].

Initialization cannot be carried out if you press [オンライン] without pressing [実行].

フブラックトナー コウカンチュウ

トナー コウカン シュウリョウ



NOTE

If <1G X トナー コウカン> appears after resetting the counter of the toner cartridge, remove the replaced toner cartridge, hold the toner cartridge so that its tab is at the bottom, shake the cartridge up and down forcefully again to evenly distribute the toner inside the cartridge, and then install the toner cartridge.

In Case of LBP5600SE

1 Display the Printer Status Window.

2 From the [Options] menu in the Printer Status Window, select [Device Settings] → [Reset Information on Consumables].

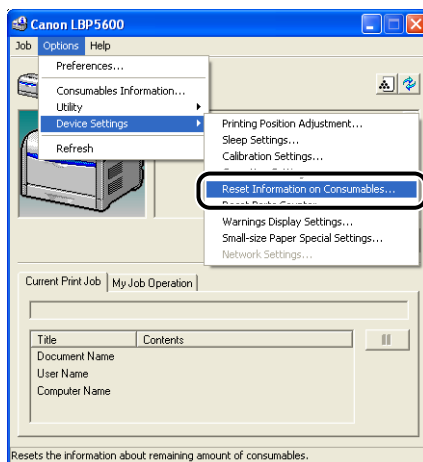

The [Reset Information on Consumables] dialog box is displayed.

- 3** Select the toner cartridge of the replaced color, and then click [OK].

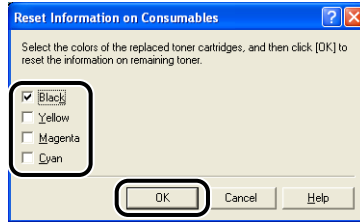

A confirmation message is displayed.

- 4** Click [Yes].

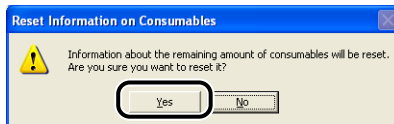

 **NOTE**

If "Toner Cartridge Replacement Required" is displayed after resetting the counter of the toner cartridge, remove the replaced toner cartridge, hold it with the tab facing down, shake it up and down strongly again, evenly distribute the toner inside the cartridge, and install it.

Replacing the Drum Cartridges

This section describes how to replace drum cartridges.

When a Message Appears

Drum cartridges are consumable products. When any drum cartridge is nearing the end of its life, a message appears on the display in case of LBP5900SE, or on the Printer Status Window in case of LBP5600SE, so follow the directions in the message.

■ LBP5900SE

Message	When it is Displayed	Contents and Remedies
EO X トラム ヨウイ (X indicates K, Y, M, or C)	When the drum cartridge needs to be replaced soon.	<ul style="list-style-type: none">- You can continue to print.- Have ready a new drum cartridge of the indicated color.- It is recommended that you replace the drum cartridge before printing a large amount of data.
EF X トラムコウカン (X indicates K, Y, M, or C)	The drum cartridge has reached the end of its life.	<ul style="list-style-type: none">- The printer stops printing.- You can continue to print for a while by pressing [オンライン], however, this may result in deterioration in print quality.- Replace the drum cartridge of the indicated color with a new one.
98 X トラムコウカン (X indicates K, Y, M, or C)	When the drum cartridge cannot be used.	<ul style="list-style-type: none">- The printer stops printing, and you cannot continue to print.- Replace the drum cartridge of the indicated color with a new one.

* "K", "Y", "C", and "M" indicate black, yellow, cyan, and magenta respectively.

■ LBP5600SE

Message	When it is Displayed	Contents and Remedies
The <Drum Color>* drum cartridge needs to be replaced soon.	When the drum cartridge needs to be replaced soon.	<ul style="list-style-type: none"> - You can continue to print. - Have ready a new drum cartridge of the indicated color. - It is recommended that you replace the drum cartridge before printing a large amount of data.
Drum Cartridge Replacement Required. The<Drum color>* drum cartridge needs to be replaced. You can continue printing, but the output may not be printed incorrectly.	The drum cartridge has reached the end of its life.	<ul style="list-style-type: none"> - The printer stops printing. - You can continue to print for a while by pressing [Resolve Error], however, this may result in deterioration in print quality. - Replace the drum cartridge of the indicated color with a new one.
Replace the <Drum Color>* drum cartridge as soon as possible.	The drum cartridge has reached the end of its life.	<ul style="list-style-type: none"> - You can continue to print for a while, however, this may result in deterioration in print quality. - Replace the drum cartridge of the indicated color with a new one.
Drum Cartridge Replacement Required. The <Drum Color>* drum cartridge needs to be replaced. Open the cover to replace the drum cartridge.	When the drum cartridge cannot be used.	<ul style="list-style-type: none"> - The printer stops printing, and you cannot continue to print. - Replace the drum cartridge of the indicated color with a new one.

* Black, yellow, magenta, or cyan will appear in <Drum Color> (More than one color may appear.).



IMPORTANT

When you are replacing the drum cartridge, be sure to use the drum cartridge designed for this printer.

Model Name	Supported Canon Genuine Drum Cartridge
LBP5900SE / 5600SE	Drum Cartridge 502 Black Drum Cartridge 502 Yellow Drum Cartridge 502 Magenta Drum Cartridge 502 Cyan



NOTE

- The lifetime of the drum cartridges (Canon Genuine Parts) used by LBP5900SE is as follows.

The numbers of the pages are estimated when printing in the following conditions.
 Printing ratio: 5 %; Print density: the default; Paper size: A4; Paper type: Plain paper,
 Continuously / 1-sided Printing

- Black (Drum Cartridge 502 Black): Approx. 50,000 pages
- Yellow (Drum Cartridge 502 Yellow): Approx. 50,000 pages
- Magenta (Drum Cartridge 502 Magenta): Approx. 50,000 pages
- Cyan (Drum Cartridge 502 Cyan): Approx. 50,000 pages
- The lifetime of the drum cartridge (Canon Genuine Parts) used by LBP5600SE is as follows.
The numbers of the pages are estimated when printing in the following conditions.
Printing ratio: 5 %; Print density: the default; Paper size: A4; Paper type: Plain paper, Continuously / 1-sided Printing
 - Black (Drum Cartridge 502 Black): Approx. 45,000 pages
 - Yellow (Drum Cartridge 502 Yellow): Approx. 45,000 pages
 - Magenta (Drum Cartridge 502 Magenta): Approx. 45,000 pages
 - Cyan (Drum Cartridge 502 Cyan): Approx. 45,000 pages
- When printing at interval of 2 sheets (the intermittency of printing for 2 sheets), the lifetime of the drum cartridges (Canon Genuine Parts) for LBP5900SE is approximately 45,000 pages for the black, approximately 40,000 pages for each color toner, while the lifetime of the drum cartridges (Canon Genuine Parts) for LBP5600SE is Black: approximately 40,000 pages for the black toner and approximately 36,000 pages for each color toner. These values are the number of pages that you can print when only color printing.
Even when printing in black and white, each of the color drum cartridges is consumed. Therefore, when printing in black and white a lot, the lifetime of each of the color drum cartridges may be half the number of pages you can print.
- Depending on the printing preferences or printing environment such as the intermittency of printing, paper type, paper size, and 1-sided / 2-sided printing, the number of pages that you can print may be half the number.

Replacing the Drum Cartridges

If a message appears, replace the drum cartridge with a new one.

WARNING

- **Do not throw a used drum cartridge into open flames, as this may cause the toner remaining inside the drum cartridge to ignite, resulting in burns or a fire.**
- **There are some areas inside the printer which are subject to high-voltages. When removing jammed paper or when inspecting the inside of the printer, do not allow necklaces, bracelets, or other metal objects to touch the inside of the printer. This may result in an electrical shock.**
- **The drum cartridge generates a low level magnetic field. If you use a cardiac pacemaker and feel abnormalities, please move away from the drum cartridge. Consult your physician immediately.**

CAUTION

- **Take care not to allow the toner to come into contact with your hands or clothing, as this will dirty your hands or clothing. If they become dirty, wash them immediately with cold water. Washing with warm water will set the toner and make it impossible to remove the toner stains.**

- The fixing unit and its surroundings inside the printer are hot during use. Do not touch the fixing unit and its surroundings. This may result in burns.

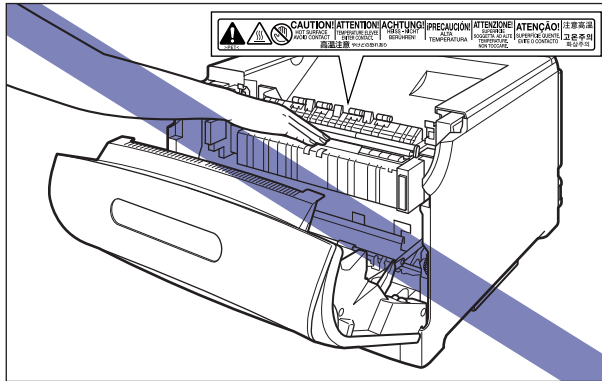

IMPORTANT

- Be sure to use only the drum cartridge designed for this printer.
- Do not install the drum cartridge that has already been used on the printer again. This may not detect the lifetime of the toner cartridges properly, and may result in damage to the cartridge.
- When handling the drum cartridge, hold the blue tabs properly as shown in the figure. Do not place it vertically or upside-down.

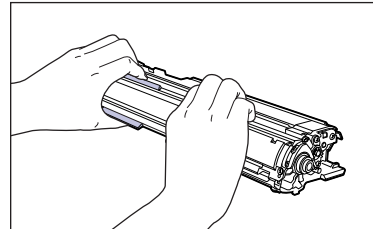
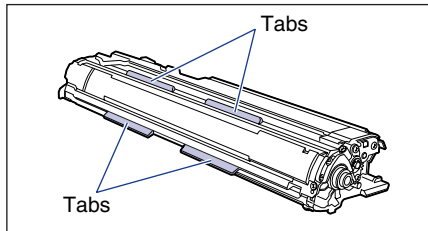

- The drum cartridge comes in a protective bag. Do not take the drum cartridge out of the protective bag until the drum cartridge is ready to be set.

- When removing or installing the drum cartridge, work from the left side of the printer as shown in the figure.

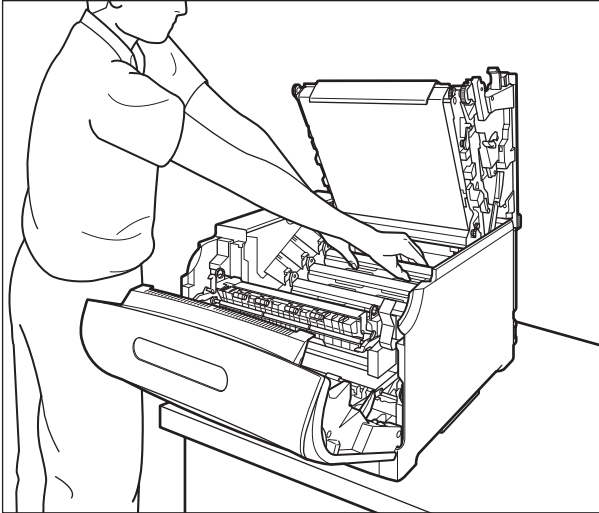

- Do not touch the high-voltage contacts in the following position. This may result in damage to the printer.
 - Inside the front cover

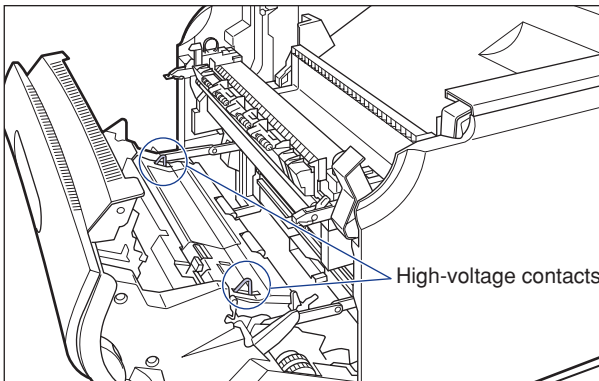

- Right side of the ITB unit, inside the printer

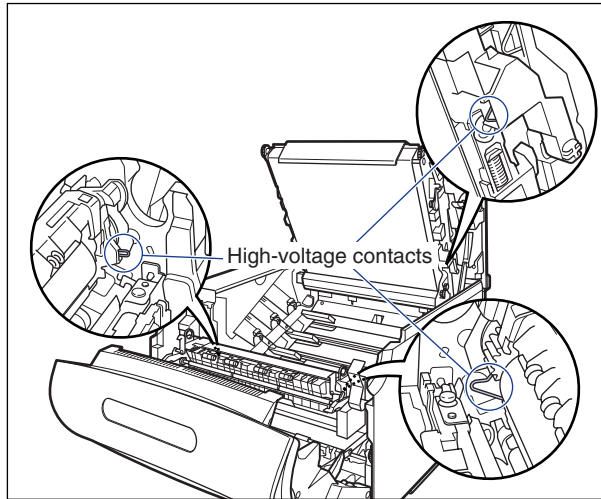

- Drum cartridge guides

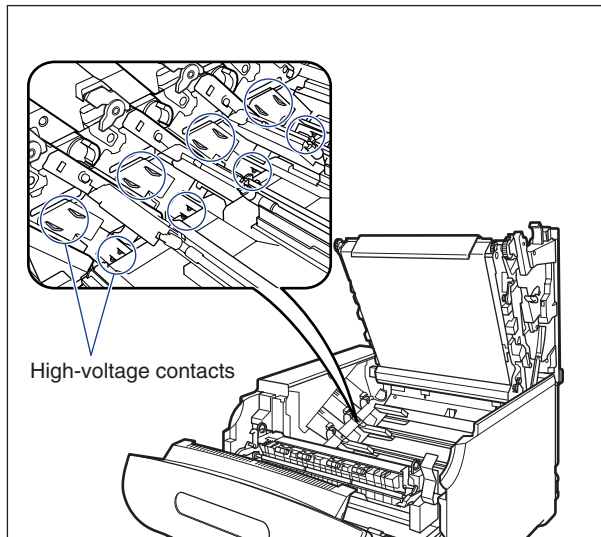

 NOTE

The packing materials may be changed in form or position to be placed, or may be added or removed without notice.

1 Open the front cover.

While pressing the lever on the right of the front cover, open the front cover toward you.

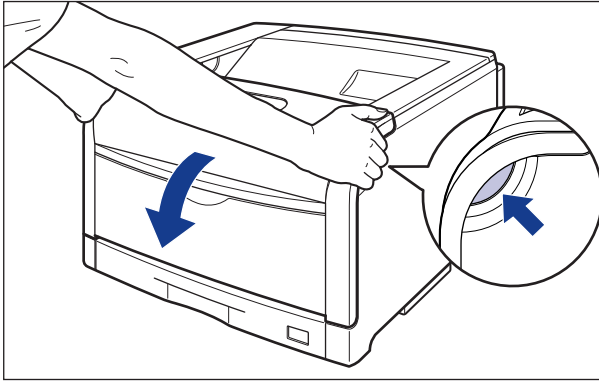

IMPORTANT

Before opening the front cover, make sure that the multi-purpose tray and the paper cassette of the printer are closed.

2 Pull the fixing unit down toward you.

While pressing the green lock release buttons ① on the left and right side of the fixing unit, hold the tabs and pull the fixing unit down toward you ② as shown in the figure.

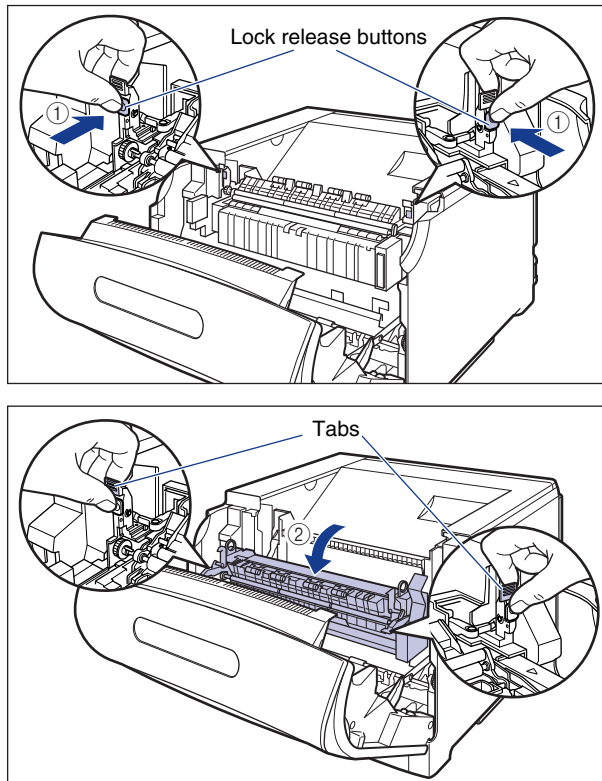

3 Open the top cover.

Press the blue lock release button of the top cover.

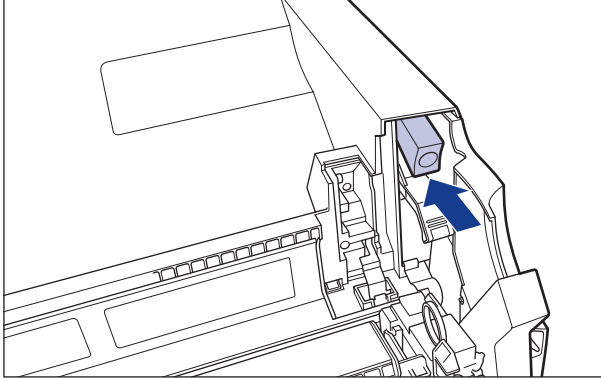

While holding the lever of the top cover, open the top cover.

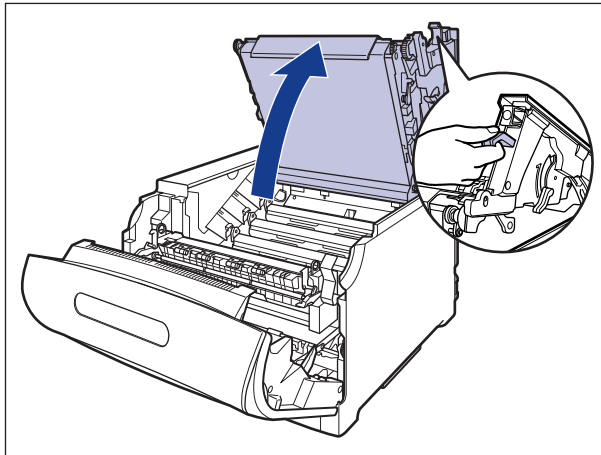

 **IMPORTANT**

- Do not touch the transfer belt of the ITB unit and the ITB unit cover. If the transfer belt is damaged, this may result in misfeeds or deterioration in print quality. The transfer belt of the ITB unit is supplied with a function that cleans itself, therefore, you do not need to clean the belt even when toner is on it.

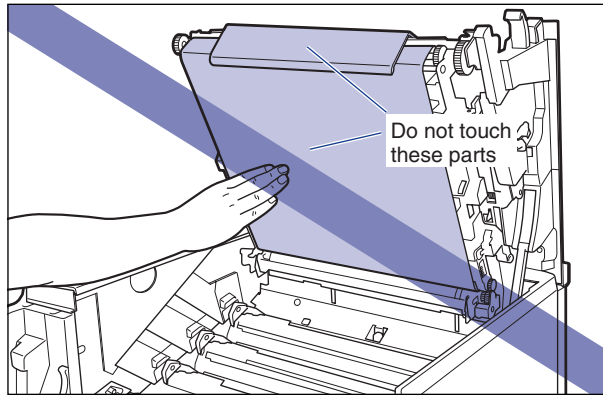

- The drum cartridges are installed from the back in order of Yellow, Magenta, Cyan, and Black.

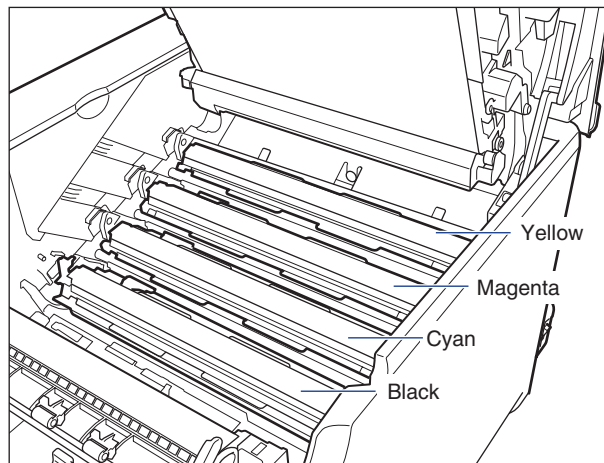

4 Slide the blue lock release lever of the drum cartridge that you want to replace to the position of "Ⓛ", and release the lock.

Slide the blue lock release lever so that the triangular mark on the lock release lever matches that of the label.

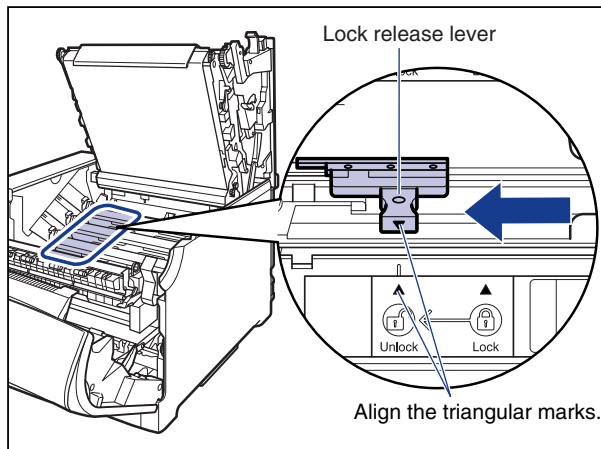

5 Remove the drum cartridge.

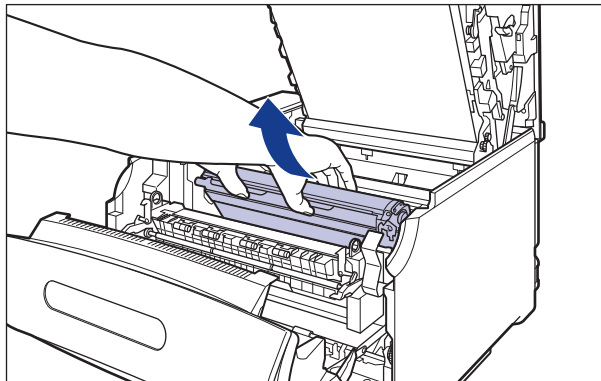

Remove the drum cartridge by holding the blue tabs as shown in the figure.

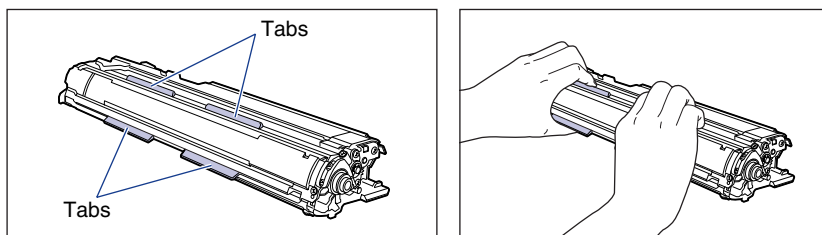

6 Take the drum cartridge out of the box, and then take it out of the protective bag.

IMPORTANT

Keep the protective bag for the drum cartridge. It may be required after taking out the drum cartridge for printer maintenance.

7 Remove the paper that indicates the cautions from the drum cartridge, and read the contents thoroughly.

After removing the tape ①, remove the paper ②.

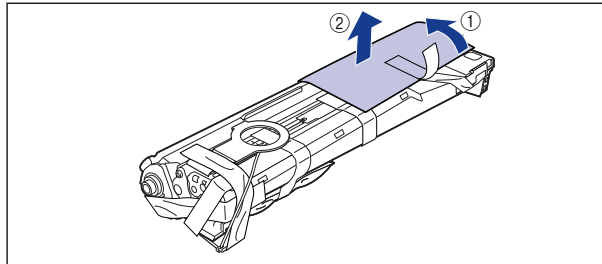

8 Remove the drying agent attached with tape (1 piece) shown in the figure.

Remove the tape ①, and then remove the drying agent ②.

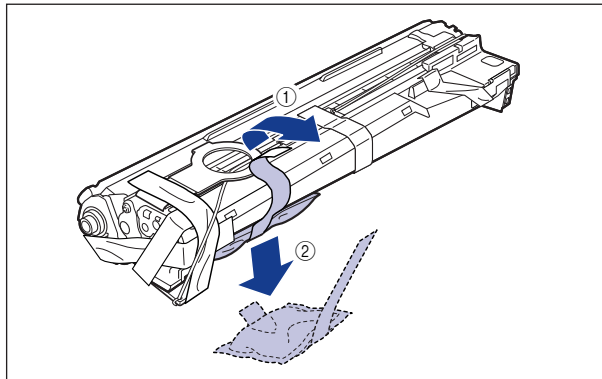

IMPORTANT

Dispose of the removed drying agent according to the local regulations.

9 Remove the packing material provided with tape (1 piece) shown in the figure.

Remove the tape ① and packing material at the same time. If the packing material cannot be removed, tilt the packing material ②, and then remove it ③.

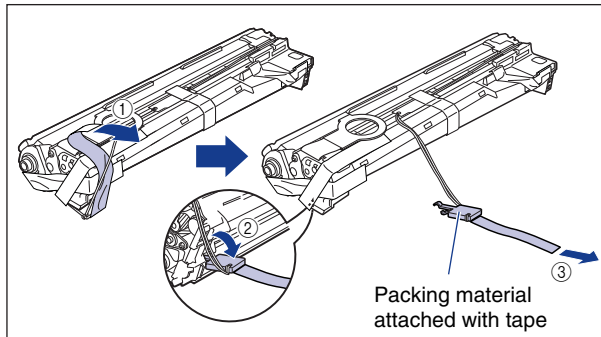

10 Remove the packing material attached with tape (1 piece) shown in the figure.

Remove the tape ① and packing material at the same time. If the packing material cannot be removed, tilt the packing material ②, and then remove it ③.

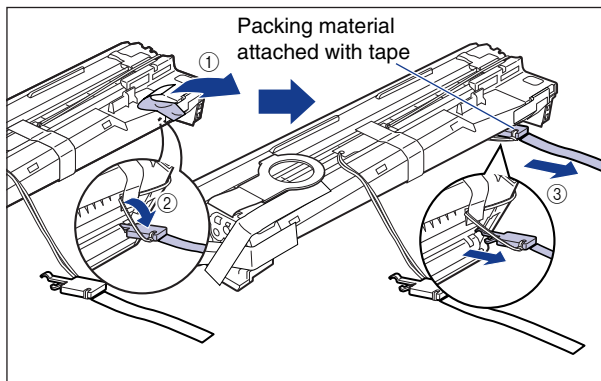

11 Remove the packing material provided with tape (1 piece) shown in the figure.

Remove the tape ①, and then pull the packing material out ②.

When removing the tape, remove the tape gently while supporting the blue shutter with hand.

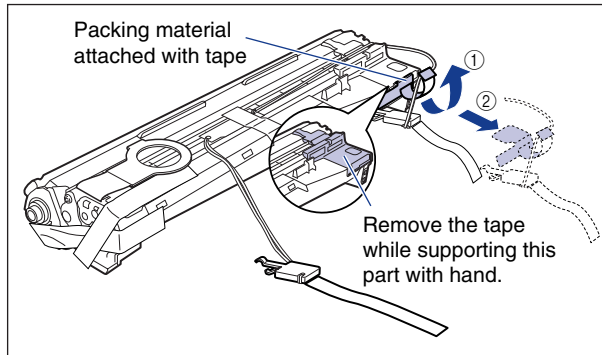

12 Remove the tape (1 piece) and tags (2 pieces) shown in the figure.

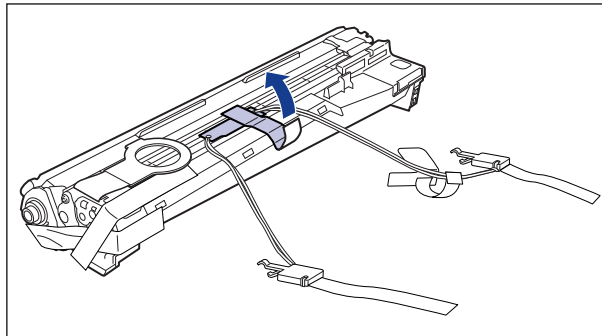

IMPORTANT

Dispose of the removed packing materials according to the local regulations.

13 Remove the tape (3 pieces) shown in the figure in order of ① and ②.

The tape to be removed in ② has another tape attached to the rear end. Remove them together.

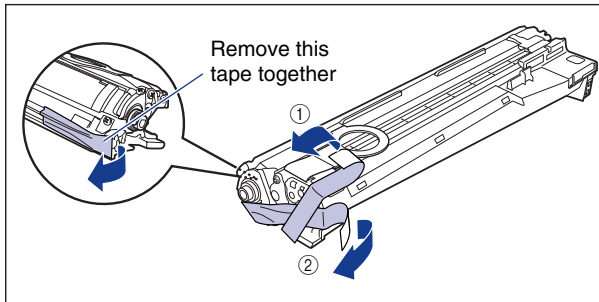

14 Hold the drum cartridge by the blue tabs and shake it up and down 10 to 12 times each as shown in the figure to evenly distribute the developer inside the cartridge.

Hold the blue tabs of the drum cartridge.

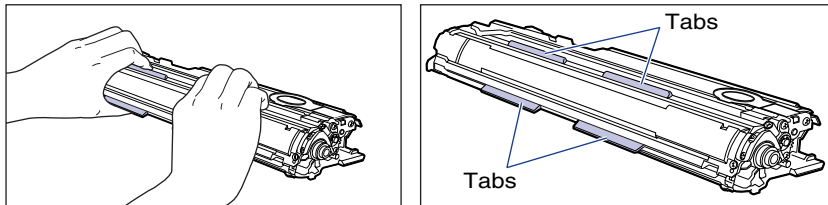

Shake the drum cartridge up and down 10 to 12 times each as shown in the figure.

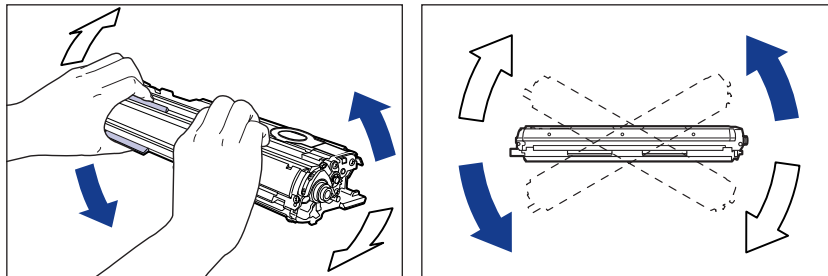

IMPORTANT

If the developer is not distributed evenly, this may result in deterioration in print quality. Be sure to carry out this procedure properly.

- 15** Place paper on a flat surface, place the drum cartridge on it, and then fold back the tab of the sealing tape as shown in the figure.

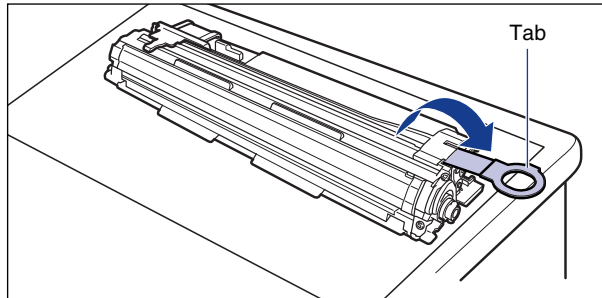

 **IMPORTANT**

- When placing the drum cartridge, be sure to place paper under the drum cartridge to prevent a desk or others from being damaged by the bottom of the drum cartridge.
- When pulling the sealing tape out, do not hold near the mouth of the sealing tape with your hand. If the tape is severed, it may become difficult to pull out completely.

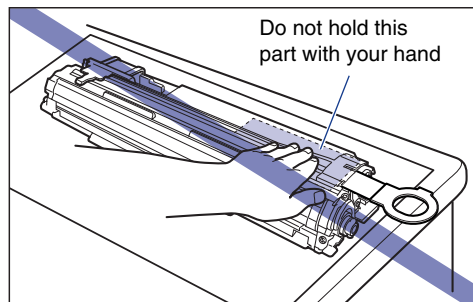

- When pulling the sealing tape out, be careful not to hold the drum protective shutter with your hands.

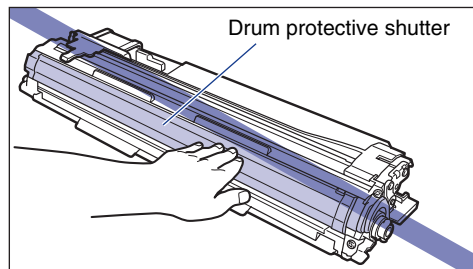

- 16** Pull the sealing tape (approx. 70 cm long) out gently and horizontally while supporting the drum cartridge. When pulling the sealing tape out, you may feel it to be heavy. However, because this is not printer malfunction, pull the sealing tape out completely.

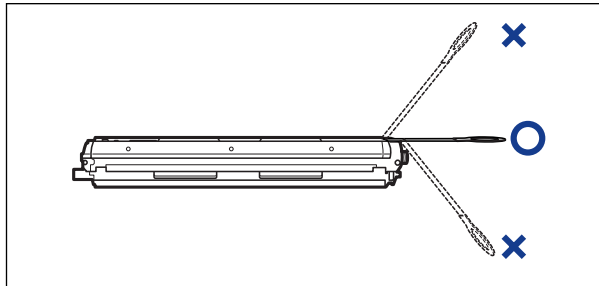
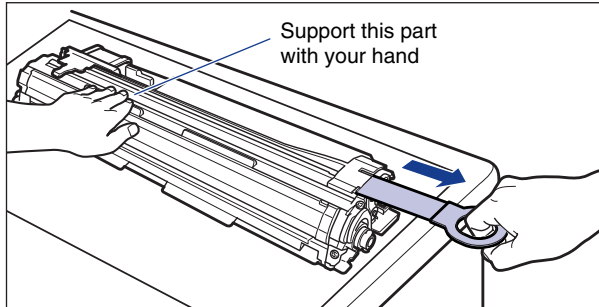

IMPORTANT

- If it is difficult to pull the sealing tape out by the tab, hold the tape and pull it out as shown in the figure. However, your hands may become dirty as toner is on the sealing tape.

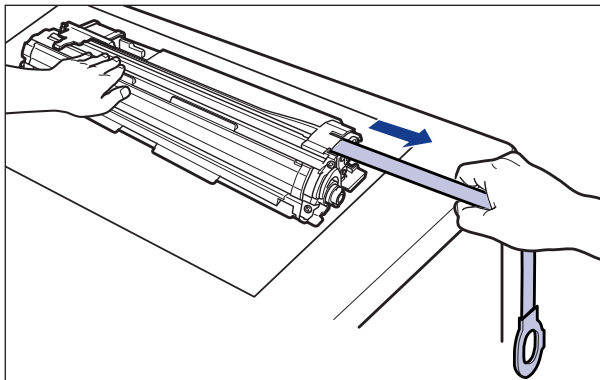

- Do not pull the sealing tape diagonally, upwards, or downwards. If the tape is severed, it may become difficult to pull out completely.

- Pull the sealing tape out completely from the drum cartridge. If any tape remains in the drum cartridge, this may result in poor print quality.
- Dispose of the removed sealing tape according to the local regulations.

17 Before installing the drum cartridge, align the triangular mark on the lock release lever with the triangular mark of "Ⓛ" on the label as shown in the figure.

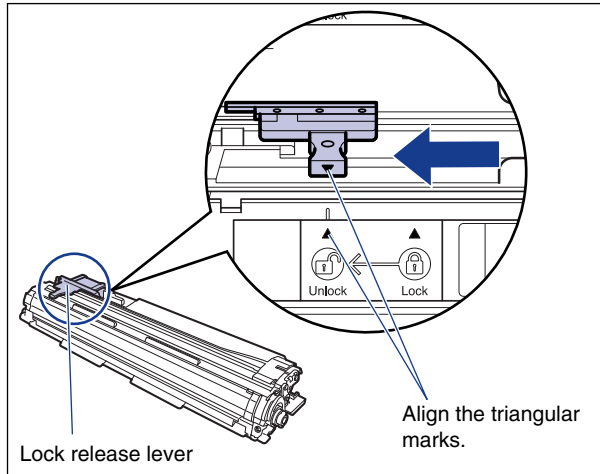

When installing the drum cartridge, hold the blue tabs as shown in the figure.

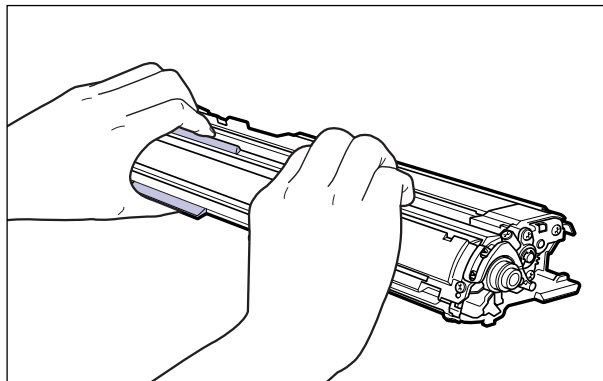

18 Make sure that the levers near the drum cartridge guides on the both sides are in the proper position as shown in the figure.

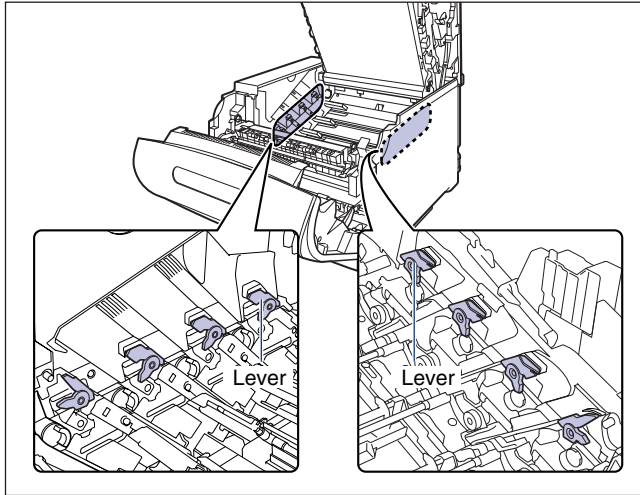

If the levers are not in the proper position, the drum cartridges cannot be installed. Raise the levers to the proper position as shown in the figure.

- Incorrect position

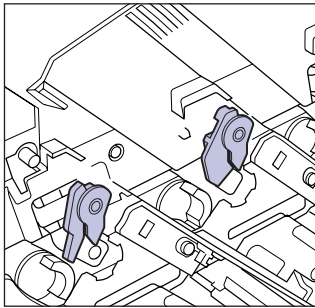

- Correct position

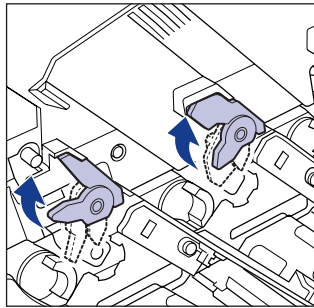

19 Install the drum cartridge into the printer.

Insert the drum cartridge firmly until it touches the back of the printer.

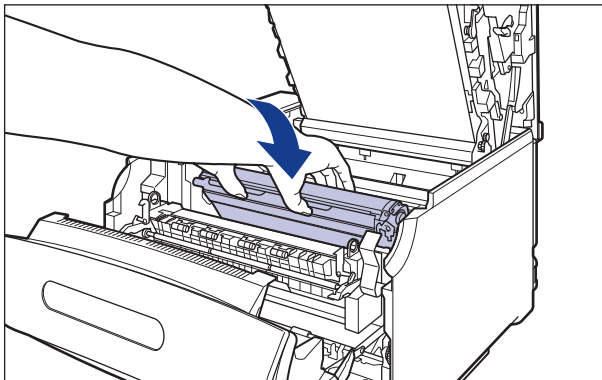

Insert the projections on each side of the drum cartridge into the drum cartridge guides as shown in the figure.

- Drum cartridge guides (left)

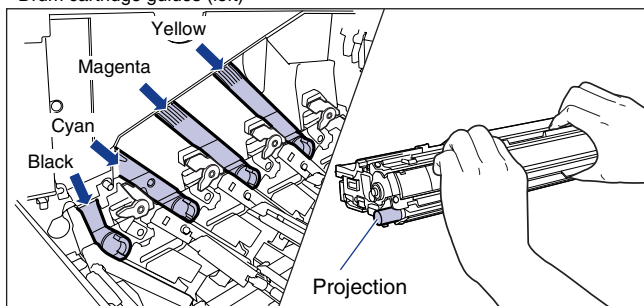

- Drum cartridge guides (right)

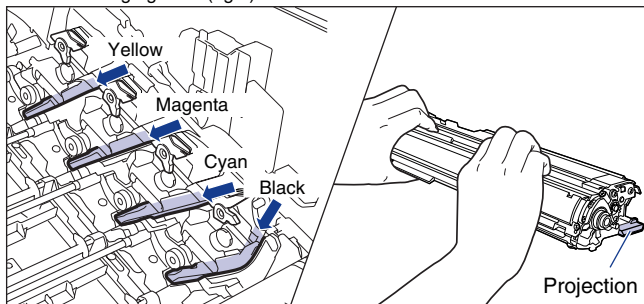

IMPORTANT

Insert the drum cartridges firmly until they touch the back of the printer. If the drum cartridges are not installed firmly, this may result in poor print quality.

- 20** Make sure that the levers near the drum cartridge guides on the both sides are in the proper position as shown in the figure.

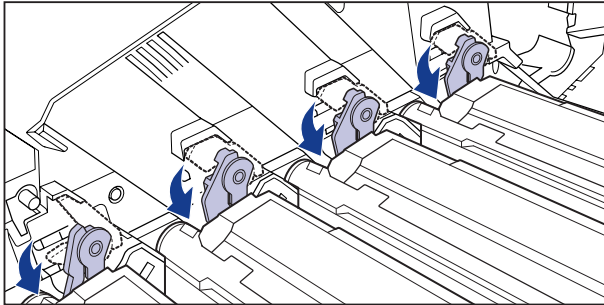

- 21** Make sure that the labels on the projections of the drum cartridge are visible.

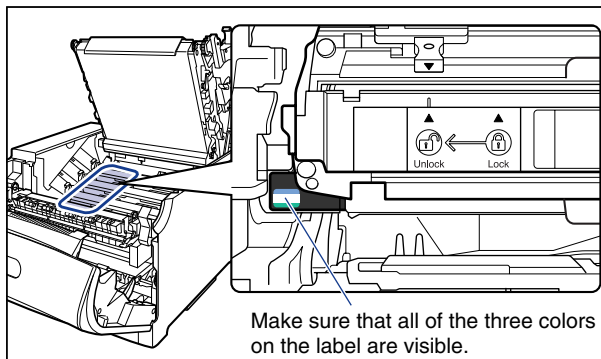

If you cannot see any of the three colors on the label from the front, take out the drum cartridge once, turn the projection in the direction of the arrow until it clicks and stops, and then reinstall the cartridge.

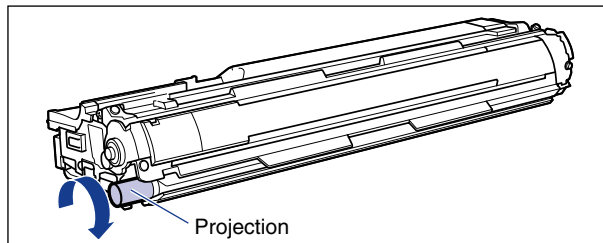

22 Slide the blue lock release lever to the position of "Ⓔ" to lock the drum cartridge.

Slide the blue lock release lever until the triangular mark on the lock release lever aligns with the triangular mark on the label.

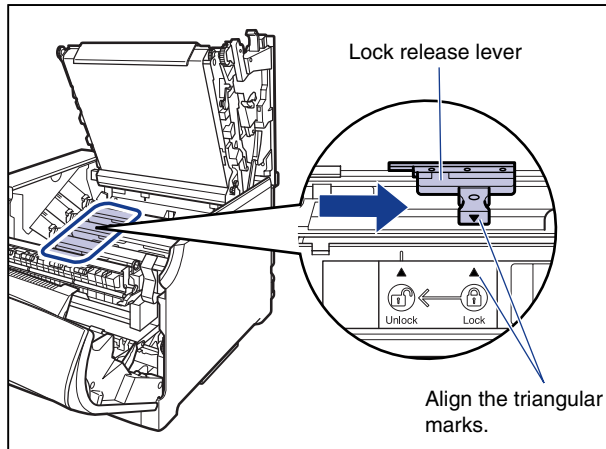

23 Close the top cover.

Close the top cover by the lever ① gently.

If you close the top cover forcefully, the ITB unit cover ② may not move back to the original position, and this may result in damage to the printer.

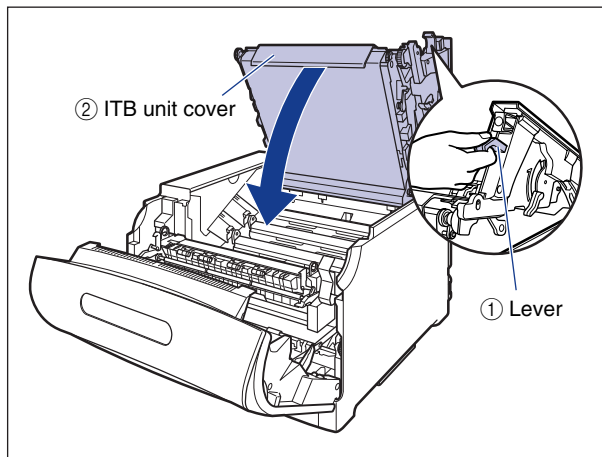

By pressing the portion indicated "PUSH", close the top cover firmly until it cannot be pressed down any further as shown in the figure.

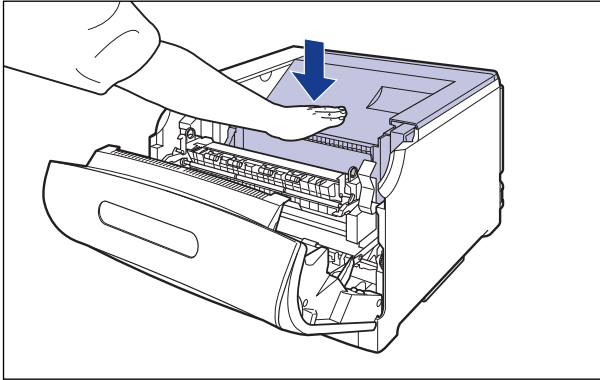

By holding the lever as shown in the figure make sure that the top cover does not open.

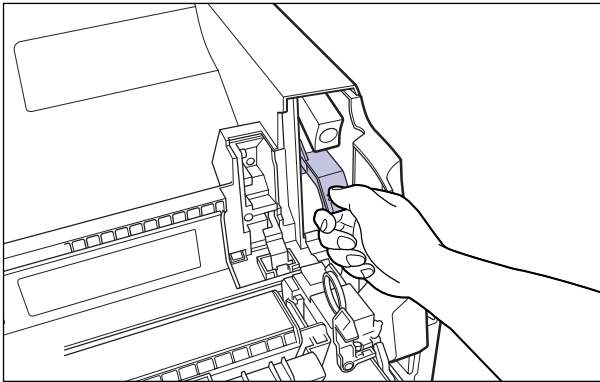

IMPORTANT

Close the top cover firmly until it cannot be pressed down any further. If the top cover is not closed firmly, this may result in poor print quality.

24 While holding the tabs, move the fixing unit back to its original position ①, and then press the tabs on the both sides as shown in the figure ②.

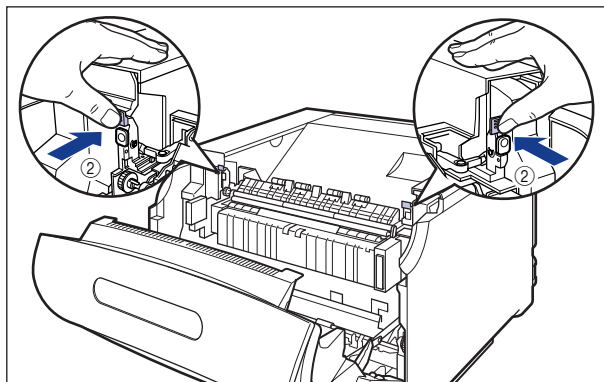
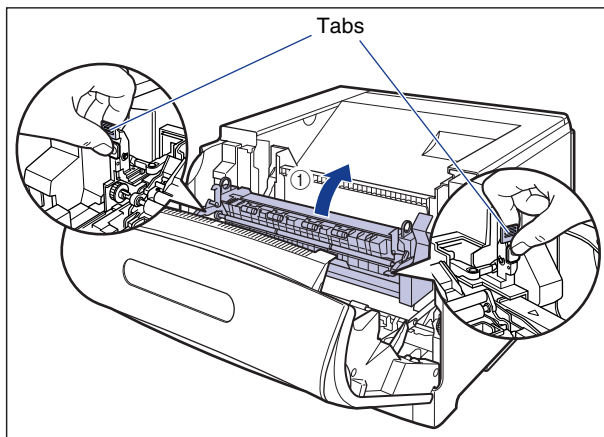

25 Close the front cover.

While supporting the front cover ①, push and close the front cover with both hands as shown in the figure ②.

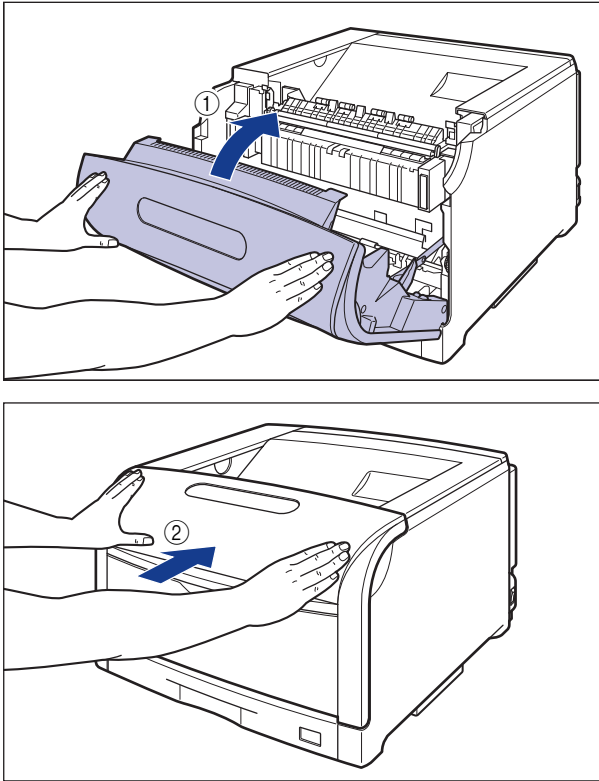

CAUTION

Push the front portion of the front cover to close it as shown in the figure. If closing the front cover by the levers on the both sides, you may catch your fingers, resulting in personal injury.

Replacing the Waste Toner Container

This section describes how to replace the waste toner containers.

When a Message Appears

When the waste toner container is full, a message appears on the display in case of LBP5900SE, or on the Printer Status Window in case of LBP5600SE, so follow the directions in the message.

■ LBP5900SE

Message	When it is Displayed	Contents and Remedies
E1 ハイトナーヨウキ ヨウイ	The waste toner container needs to be replaced soon.	<ul style="list-style-type: none">- You can continue to print.- Have ready a new waste toner container.
E1 ハイトナーヨウキ コウカン	The waste toner container is full.	<ul style="list-style-type: none">- The printer stops printing.- Replace the waste toner container with a new one.

■ LBP5600SE

Message	When it is Displayed	Contents and Remedies
The waste toner container needs to be replaced soon.	The waste toner container needs to be replaced soon.	<ul style="list-style-type: none">- You can continue to print.- Have ready a new waste toner container.
Waste Toner Container is Full. Open the cover and replace the waste toner container.	The waste toner container is full.	<ul style="list-style-type: none">- The printer stops printing.- Replace the waste toner container with a new one.

IMPORTANT

When you are replacing the waste toner container, be sure to use the waste toner container designed for this printer.

Model Name	Supported Canon Genuine Waste Toner Container
LBP5900SE / 5600SE	WASTE TONER BOX WT-98B

- You cannot reinstall a waste toner container for which the following messages have appeared after you remove it from the printer. If you do so, the toner inside the container may spill out. Be sure to replace the waste toner container with a new one.

LBP5900SE	E1 ハイトナーヨウキ ヨウイ E1 ハイトナーヨウキ コウカン
LBP5600SE	The waste toner container needs to be replaced soon. Waste Toner Container is Full

 NOTE

- The waste toner container (Canon Genuine Parts) is full with approx. 6,200 pages. The numbers of the pages are estimated when printing in the following conditions. Printing ratio: 5 %; Print density: the default; Paper size: A4; Paper type: Plain paper, 2 sheets intermittency of printing / 1-sided printing
- Depending on the printing preferences or printing environment such as the intermittency of printing, paper types, paper sizes, and 1-sided / 2-sided printing, the number of pages that you can print may be half this number.

Replacing the Waste Toner Container

If the message appears, replace the waste toner container with new one using the following procedure.

 **WARNING**

- **Do not throw a used waste toner container into open flames, as this may cause the toner remaining inside the waste toner container to ignite, resulting in burns or a fire.**
- **There are some areas inside the printer which are subject to high-voltages. When removing jammed paper or when inspecting the inside of the printer, do not allow necklaces, bracelets, or other metal objects to touch the inside of the printer. This may result in an electrical shock.**

 **CAUTION**

- **Take care not to allow the toner to come into contact with your hands or clothing, as this will dirty your hands or clothing. If they become dirty, wash them immediately with cold water. Washing with warm water will set the toner and make it impossible to remove the toner stains.**

- The fixing unit and its surroundings inside the printer are hot during use. Do not touch the fixing unit and its surroundings. This may result in burns.

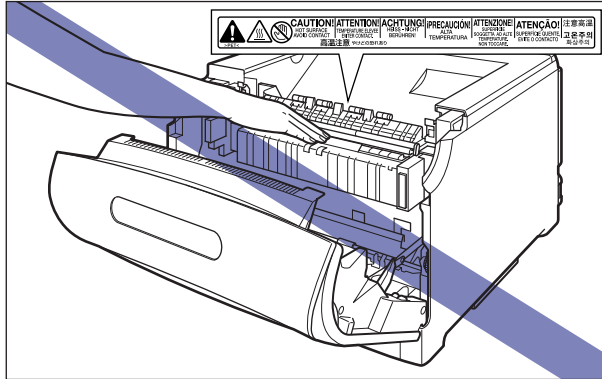

IMPORTANT

- Be sure to use only the waste toner container designed for this printer.
- You cannot reinstall a waste toner container for which the following messages have appeared after you remove it from the printer. If you do so, the toner inside the container may spill out. Be sure to replace the waste toner container with a new one.

LBP5900SE	E1 ハイトナーヨウキ ヨウイ E1 ハイトナーヨウキ コウカン
LBP5600SE	The waste toner container needs to be replaced soon. Waste Toner Container is Full

- The waste toner cannot be reused. Do not mix the waste toner with the new one.
- Never touch the high-voltage contacts inside the front cover. This may result in damage to the printer.

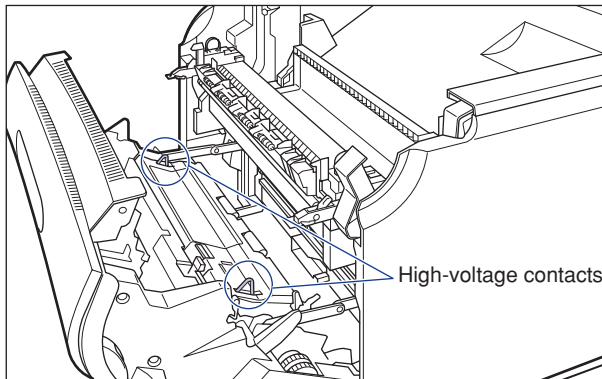

NOTE

The packing materials may be changed in form or position to be placed, or may be added or removed without notice.

1 Open the front cover.

While pressing the lever on the right side of the front cover, open the front cover toward you.

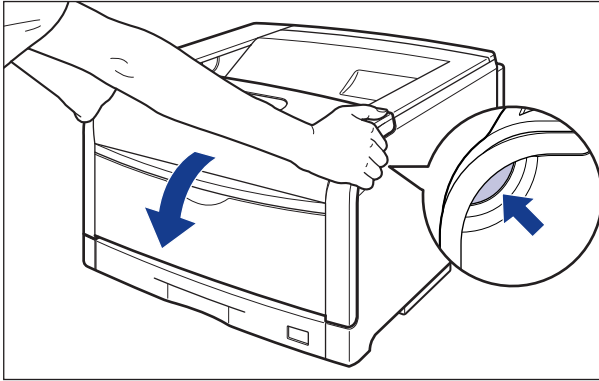

IMPORTANT

Before opening the front cover, make sure that the multi-purpose tray and the paper cassette of the printer are closed.

2 Hold the tab on the wasted toner cover, and open the wasted toner cover.

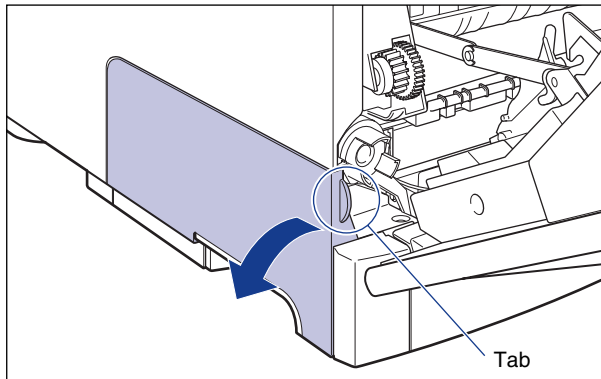

3 Remove the waste toner container.

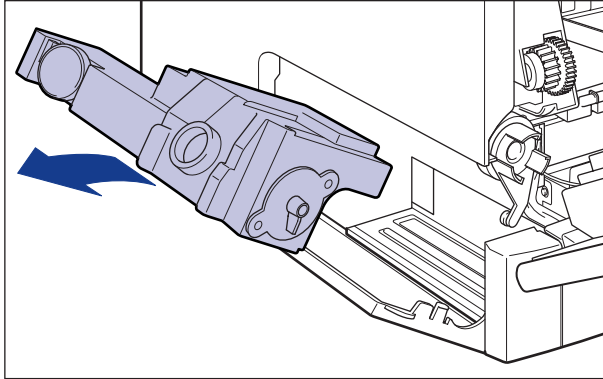

4 Install the supplied flap to the waste toner container.

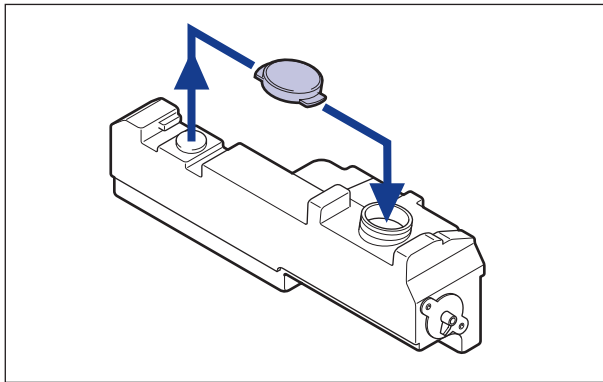

5 Take a new waste toner container out of the protective bag.

6 Install the waste toner container.

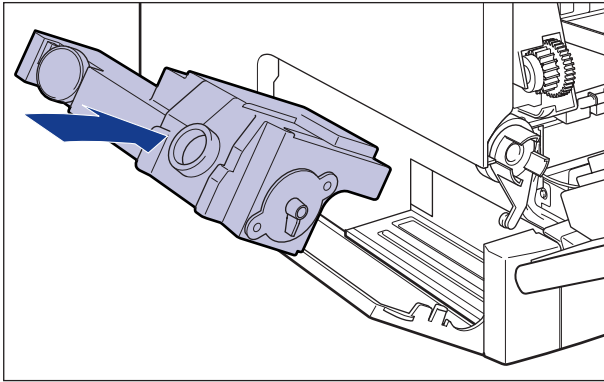

7 Hold the tab on the wasted toner cover, and close the wasted toner cover.

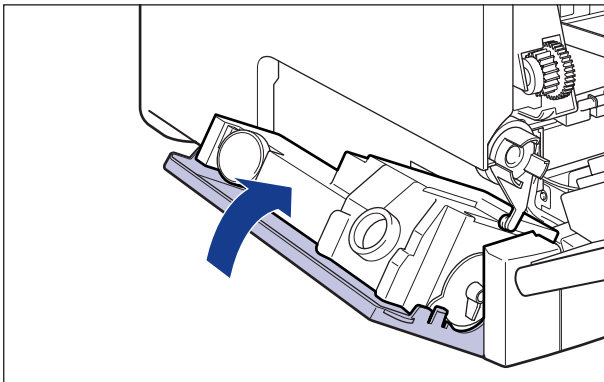

8 Close the front cover.

While supporting the front cover ①, push and close the front cover with both hands as shown in the figure ②.

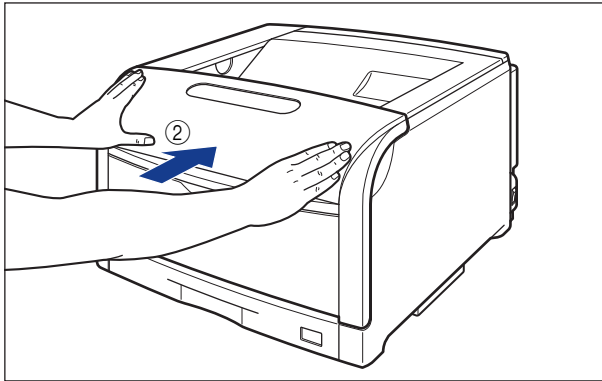
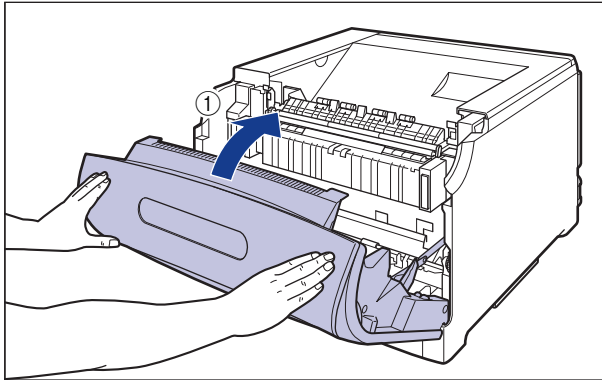

CAUTION

Push the front portion of the front cover to close it as shown in the figure. If closing the front cover by the levers on the both sides, you may catch your fingers, resulting in personal injury.

Canceling a Job (Only for LBP5900SE)

When you want to cancel the current job, perform "Job Cancel" using the following procedure. Job Cancel allows you to cancel the job that currently being received or processed.

This option does not affect the next print data or the jobs that have not been processed yet.



IMPORTANT

- Perform Job Cancel when processing data (the ジョブ indicator is on or blinking). If pressing [ジョブキャンセル] when the ジョブ indicator is off, Job Cancel cannot be performed.
- Data that has already finished processing and that is in print processing (print source operation started) cannot be canceled. In this case, the next print data may be canceled.
- In case of containing print data sent from the printer driver that is not designed for this printer, multiple data may be canceled.



NOTE

When performing Job Cancel, the job may not be canceled regardless of displaying <03 ジョブ キャンセル>. The secure print job before entering the password and the job to be saved in the box cannot be canceled. Delete the secure print job before entering the password and the job to be saved in the box with Remote UI.

Perform Job Cancel using the following procedure. Be sure to perform Job Cancel when ジョブ indicator is on or blinking (when the job to be canceled is receiving or processing data).

ジョブキャンセル



1 Press [ジョブキャンセル].

実行



2 When canceling the job, press [実行].

キャンセル シェックウ?

03 ジョブ キャンセル

00 インサツ カノウ A4

Displays <03 ジョブ キャンセル> and cancels processing print data.
When <00 インサツ カノウ> is displayed, Job Cancel is completed.



IMPORTANT

When <03 ジョブ キャンセル> is displayed, the printer cannot be operated.

Deleting/Pausing/Resuming a Job (Only for LBP5600SE)

You can delete, pause, or resume a job in the Printer Status Window.

1 Start printing.

The Printer Status Window appears.



NOTE

The Printer Status Window may not appear depending on the settings for [Display Printer Status Window] in the [Preferences] menu in the Printer Status Window.

2 When deleting or pausing the job, click the [Pause Job] button in the [Current Print Job] tab or [My Job Operation] tab.

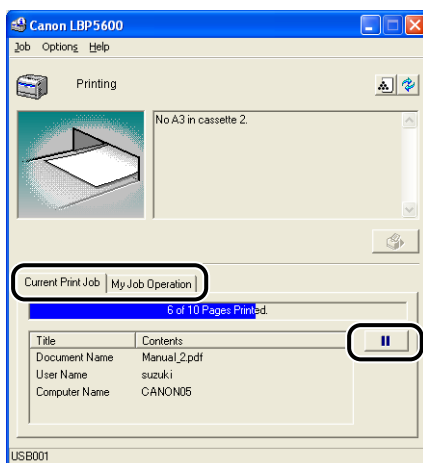

The following message is displayed and the [My Job Operation] tab is displayed by clicking the [Pause Job] button in the [Current Print Job] tab.

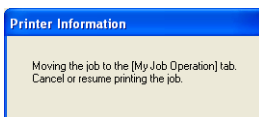

3 Click the button for the desired operation from among the [Job Operation] buttons.

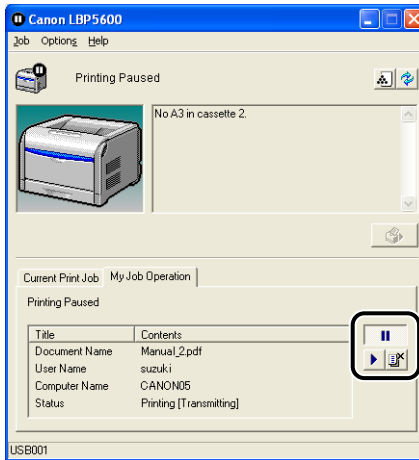

● **Deleting a Job**

[Click [] (Delete Job).

● **Pause a Job**

[Click [] (Pause Job).

● **Resuming the Job**

[Click [] (Resume Job).

Confirming the Printer Features

In Case of LBP5900SE

This printer has the function of Status Print that allows you to confirm such as the settings in the menu. Use these functions when required after installing and connecting the printer, for example when you want to check the operation.

The Status Print prints the list of the functions and settings in the menu that can be used currently. Perform Status Print using the following procedure.

NOTE

- Status Print is designed to be printed on A4 size paper. Other paper size can be printed, however, in this case the Status Print may be reduced or enlarged, printed partially or disproportionately.
- The settings in the menu from the control panel reflect the Status Print. For example, when automatic 2-sided printing is selected, the Status Print is also printed 2 pages on the both sides. However, the number of pages for copy is set aside, so one sheet of paper is always printed.

オンライン



1 Make sure that the printer is online.

If the printer is not online, press [オンライン].

ユーティリティ



2 Press [ユーティリティ].

ユーティリティ

ステータスプリント →

< ステータスプリント > appears on the display.

実行



3 Press [実行].

ステータスプリント →

シッコウ チュウ

Displays for approx. 1 second.

ステータスプリント →

Status Print is printed.

4 Confirm the contents of the Status Print.

Status Print prints information as shown in the following figure. The Status Print allows you to make sure of the list of the functions and settings in the menu that can be used currently, the software that is installed in the printer, the version name of the hardware, and a number of pages. You can check the number of total print pages using "Page Count" on the lower right of the Status Print.



IMPORTANT

This is a sample of Status Print. The contents may differ from the Status Print printed by your printer.

ステータスプリント
LBP5900

総RAM容量: 256 MB

<p>バージョン: ●●●●●●●● サブバージョン: ●●●●●●●●●● エンジンバージョン: ●●●●●●●●●● ハードディスク名簿: ●●●●●●●●●●●●●●</p> <p>拡張機能グループ</p> <p>スリープモード/バネルオフ スリープモード復帰時間: 30秒 深い睡眠モード/交換予告: 機能なし 自動エラースキップ: しない 表示言語: 日本語 音声: 1104 警告表示/トナー交換予告: する 定額課金機能: しない 廃トナー容器交換予告: する 不正な交換予告: する カセット用紙なし: する メール通知: する ウェイクアップタイマー: 機能しない ウェイクアップ時刻: 12:00 スリープタイマー: 機能しない スリープ時刻: 12:00 キャリブレーションタイマー: 機能しない キャリブレーション時刻: 12:00 ハードディスク: 使う 取り込み印刷: 許可する セキュアプリント/過去までの時間: 4時間 セキュアプリント保存形式: イメージ RIP: On: 使う 印刷範囲保護: しない 語言モード移行時間: 10秒</p> <p>印字調整グループ</p> <p>データ処理: ファイ(400dpi) 印刷速度: 高効率 トラフモード: 使わない トナー濃度(電圧オフ): 9 M(マゼンダ): 9 Y(イエロー): 9 K(ブラック): 9 カラーモード: 自動 モノクロ印刷/調整キースト: 解像度 グラフィック: 標準 イメージ: 標準 カラー中間調キースト: 解像度 グラフィック: 標準 イメージ: 標準 グレー補正キースト: する グラフィック: 標準 イメージ: しない</p> <p>デバイスID: ●●●●●●●● Model: ●●●●●●●● Description: ●●●●●●●●●●</p> <p>搭載コントローラ: LIPS: ●●●●●●●●●● LIPS LX: ●●●●●●●●●●●●●● ESCP: ●●●●●●●●</p> <p>標準ネットワーク: バージョン: ●●●●●●●● MAC Address: ●●●●●●●●●●●●●●</p> <p>USB: ベンダID: ●●●●●●●● プロダクトID: ●●●●●●●● シリアルナンバー: ●●●●●●●●●●●●●● USB印刷モード: ●●●</p>	<p>給紙グループ</p> <p>デフォルト用紙サイズ: A4 手戻しレイ用紙サイズ: A4 手戻しレイで紙: しない 用紙名: 変時トレイ: 使わない 自動選別/手戻しトレイ: 使う カセット1: 使う カセット2: 使う カセット3: 使う カセット4: 使う 用紙名簿/手戻しトレイ: ●●●●●●●● カセット1: ●●●●●●●● カセット2: ●●●●●●●● カセット3: ●●●●●●●● カセット4: ●●●●●●●●</p> <p>デフォルト用紙サイズ: 普通紙 手戻しレイ用紙サイズ: 普通紙 カセット1用紙サイズ: 普通紙 カセット2用紙サイズ: 普通紙 カセット3用紙サイズ: 普通紙 カセット4用紙サイズ: 普通紙 手戻し両面: 両面 手戻し両面: 両面 両面印刷: しない</p>	<p>レイアウトグループ</p> <p>コピー枚数: 1枚 コピー補正: 0.0mm 縦向き補正: 0.0mm とじ方向: 長辺とじ とじしろ: 40.0mm 特殊両面処理: する</p> <p>インタフェースグループ</p> <p>インタフェース選択/セントロロックス: 使う USB: 使う 無線LAN: ●●●●●●●● タイムアウト: 15秒 セントロロックス/インテック/タイム: 使わない コネクション: 機能しない 拡張受信/パワープ: 使わない</p> <p>動作モードグループ</p> <p>動作モード選択/自動選択 自動切戻/LIPS: 使う ESCP: 使う 最先エミュレーション: しない</p> <p>ユーザメンテナンsgループ</p> <p>トレイ幅(紙厚): 0.0 mm 縦向き補正: 0.0 mm カセット1縦向き補正: 0.0 mm 縦向き補正: 0.0 mm カセット2縦向き補正: 0.0 mm 縦向き補正: 0.0 mm カセット3縦向き補正: 0.0 mm 縦向き補正: 0.0 mm カセット4縦向き補正: 0.0 mm 縦向き補正: 0.0 mm 両面縦向き補正: 0.0 mm 横向き補正: 0.0 mm リカバリ印刷: する 特殊モード1: 使わない 用紙サイズ調整: しない 両面縦向き処理: しない 小サイズ特殊処理: しない 特殊印字処理/普通紙: しない コード紙: しない</p> <p>CMS(マッパッチング)選択: プリント CMS(マッパッチング)設定: ガンマ グラフィック: ガンマ イメージ: シフト RGBスプループロファイル/デキスト: sRGB_v1.31 グラフィック: sRGB_v1.31 イメージ: sRGB_v1.31 出力プロファイル/デキスト: Normal グラフィック: Normal イメージ: Photo マッチング方法/デキスト: 色のみ後発 グラフィック: 色のみ後発 イメージ: 色のみ後発 ガンマ補正/デキスト: 1.4 グラフィック: 1.4 イメージ: 1.4 両頁警告: 詳細</p> <p>Manufacturer: ●●●●●●●● Model: ●●●●●●●● Description: ●●●●●●●●●●</p> <p>LIPSは、キヤノン株式会社の商標です。 ESCPは、セイコーエプソン株式会社の商標です。</p> <p>カートリッジ情報: Cカートリッジ寿命: 99頁 Mカートリッジ寿命: 79頁 Yカートリッジ寿命: 53頁 Kカートリッジ寿命: 50頁</p> <p>最終発行日時: 2000/01/15 09:00 総印刷ページ数: 0000001</p>
---	---	--

CanonおよびCanonロゴはキヤノン株式会社の商標です。

2005/06/15 09:17:11 Page Count : 0000061

In Case of LBP5600SE

This printer has the function of Printer Status Print that allows you to confirm the optional settings of the printer, settings for [Device Settings] in the [Options] menu in the Printer Status Window, and the current printer status such as number of total printed pages. Use these functions when required after installing and connecting the printer, for example when you want to check the operation.

 NOTE

Printer Status Print is designed to be printed on A4 size paper. Load A4 size paper.

1 Display the Printer Status Window.

2 From the [Options] menu in the Printer Status Window, select [Utility] → [Printer Status Print].

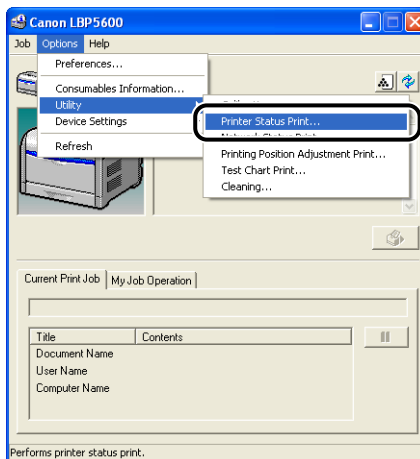

A confirmation message is displayed.

3 Click [OK].

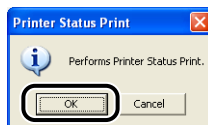

Printer Status Print is printed.

4 Confirm the contents of the Printer Status Print.

Printer Status Print prints information as shown in the following figure. You can confirm the optional settings of the printer, settings for [Device Settings] in the [Options] menu in the Printer Status Window, and the current printer status such as a number of total printed pages.



IMPORTANT

This is a sample of Printer Status Print. The contents may differ from the Printer Status Print printed by your printer.

Canon		Status Print
Options		
Cassette 2	:	Exist
Cassette 3	:	None
Cassette 4	:	None
Network Board	:	Exist
Device Settings		
Sleep Mode Settings		
Sleep Mode	:	On
Time to Enter Sleep Mode	:	30 minutes
Calibration Settings		
Periodical Calibration Timer	:	Off
Calibration Time	:	9:00
Warnings Display		
Toner Cartridge Replacement Notice	:	On
Drum Cartridge Replacement Notice	:	On
Waste Toner Container Replacement Notice	:	On
Fixing Unit Replacement Notice	:	On
Auto Select		
Cassette 1	:	On
Cassette 2	:	On
Cassette 3	:	On
Cassette 4	:	On
Feed Direction of Custom Paper Size		
Cassette 2	:	Short Edge Feed
Cassette 3	:	Short Edge Feed
Cassette 4	:	Short Edge Feed
Printing Position Adjustment		
Multi-purpose Tray	:	0.0 mm
Cassette 1	:	0.0 mm
Cassette 2	:	0.0 mm
Cassette 3	:	0.0 mm
Cassette 4	:	0.0 mm
Duplex Unit	:	0.0 mm
Small-size Paper Special Settings		
Small-size Paper Special Process 1	:	0
Small-size Paper Special Process 2	:	0
Printer Date & Time	:	2005/06/21 21:22
Product Name		
Product Name	:	LBP5600
Controller Version		
Controller Version	:	XXXX
Engine Version		
Engine Version	:	XXXX
Driver Version		
Driver Version	:	XXXX
USB		
Vendor ID	:	0x04a9
Product ID	:	0x2645
Serial Number	:	XXXXXXXXXX
Last Calibration Information		
Date and Time	:	Invalid
Number of Total Printed Pages	:	48
Counter		
Date And Time	:	2005/06/21 21:22
Number of Total Printed Pages	:	48
Color S Print Pages	:	20
Color L Print Pages	:	0
B&W S Print Pages	:	27
B&W L Print Pages	:	1
Number of 2-sided Printing Sheets	:	0
Number of Jobs	:	18
Canon and Canon logo are trademarks of CANON INC.		

Service Call Display

In Case of LBP5900SE

When a problem has occurred and the printer does not work properly, the following service call appears.

Message	Cause	Remedy
<p>E_{nnn}-_{nnnn}</p> <p>(n indicates alphanumeric characters)</p>	A problem has occurred inside the printer.	Cycle the power of the printer using the following procedure. If the message does not disappear regardless of cycling a few times, contact your local authorized Canon dealer.
<p>E001-_{nnnn}</p> <p>E003-_{nnnn}</p> <p>(n indicates alphanumeric characters)</p>	A problem has occurred in the fixing unit of the printer.	Follow the instructions 2 or later, and contact your local authorized Canon dealer.

- 1** Turn the printer OFF, wait for 10 seconds or longer, and then turn it ON again.

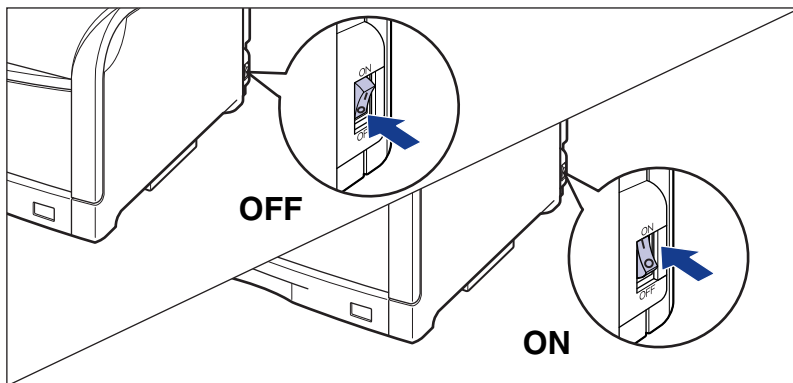

If the message does not reappear, the printer can be used as is. If the message still appears, proceed to the next step.

- 2** Note down eight-digit alphanumeric characters and the message that appear on the display.
- 3** Turn the printer and the computer OFF ①, remove the USB cable ②, disconnect the power plug from the AC power outlet ③, and then remove the ground wire from the ground terminal ④.

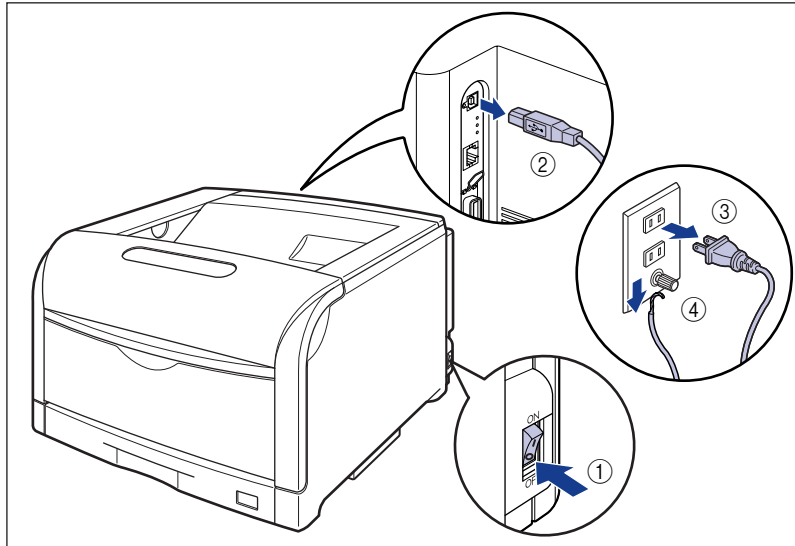

- 4** Contact your local authorized Canon dealer.

When contacting your Canon dealer, please report the problems and eight-digit alphanumeric characters that you have noted.

In Case of LBP5600SE

When a problem has occurred and the printer does not work properly, the エラー (error) indicator (red) comes on and the following service call appears in the Printer Status Window.

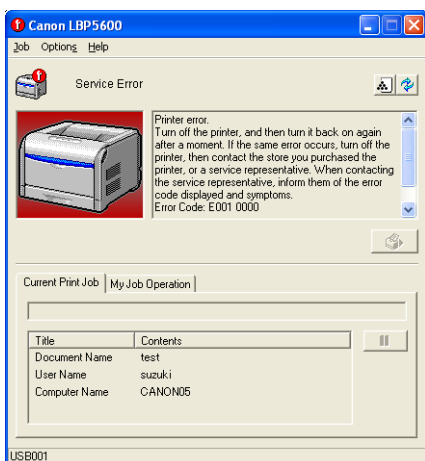
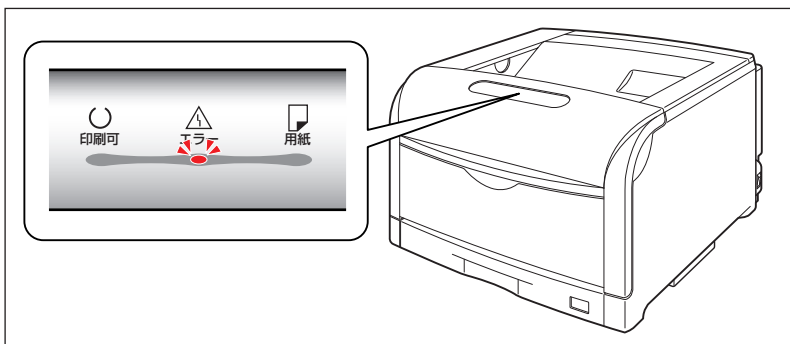

If the service call appears, cycle the power of the printer using the following procedure. This may clear the message.

- 1 Turn the printer OFF, wait for 10 seconds or longer, and then turn it ON again.

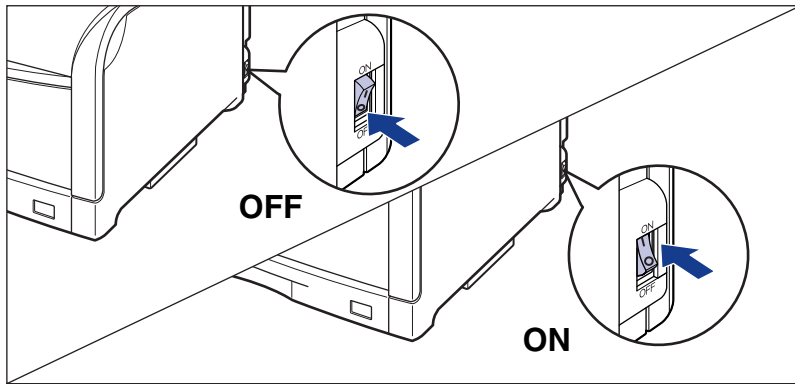

If the message does not reappear, the printer can be used as it is. If the message still appears, proceed to the next step.

- 2 Note down the error code displayed in the Printer Status Window.

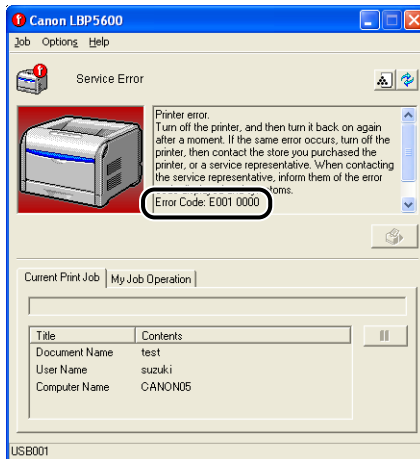

3 Remove the rear cover.

Open the rear cover a little ①, then remove the rear cover ②.

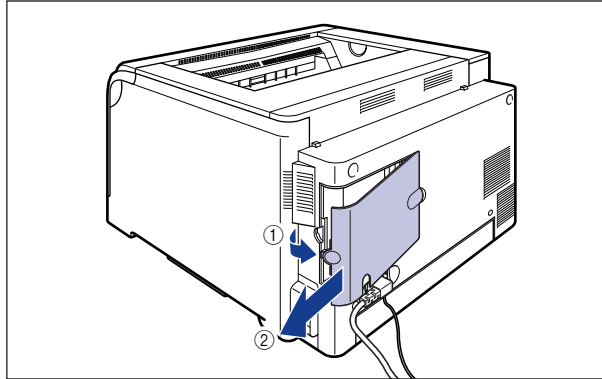

4 Turn the printer and the computer OFF ①, remove the USB cable ②, disconnect the power plug from the AC power outlet ③, and then remove the ground wire from the ground terminal ④.

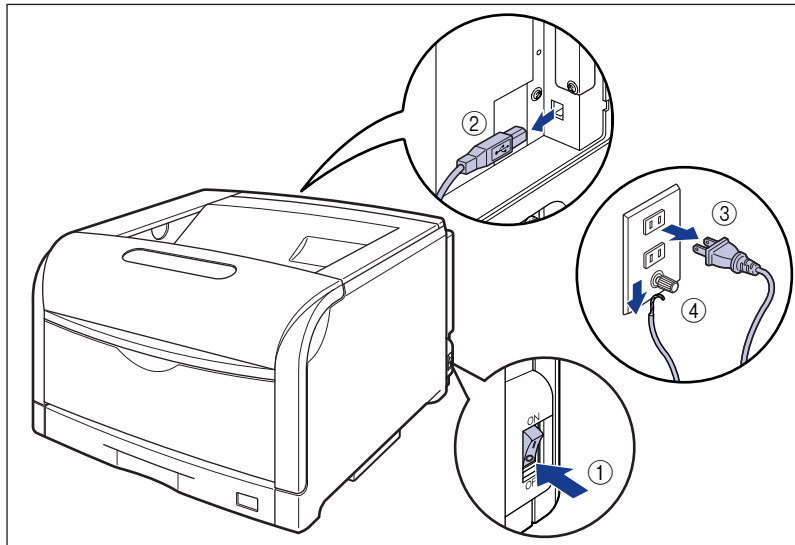

5 Contact your local authorized Canon dealer.

When contacting your Canon dealer, please report the problems and the error code that you have noted.

Message List (Only for LBP5900SE)

If the printer cannot print for any reason (an error is occurring) when using the printer, warning beep sounds, the メッセージ indicator comes on, and an error message that indicates the contents of the trouble) appears on the display. When any remedy is required although this status does not affect the job (Warning), a warning message appears on the display.

When these messages are displayed, follow the instruction in the message and take the following measures.

NOTE

- When multiple warnings occur at the same time, warning messages are displayed alternately.
- When an error and warning occur at the same time, the warning message is not displayed.
- When the message with <Warning Message> appears, the message does not appear in case of setting <ケイコク ヒョウジ> in the セットアップ menu to <シナイ>.
- When the message with <Error Skip> mark appears, you can perform the error skip and continue to print by pressing [オンライン], however, the print data may be missed and the printer may not print properly. When canceling the processing, perform the operation of the soft reset, clear the cause of error off, press [オンライン] and print again. When the message with this mark appears, the error skip can be performed in case of setting <ジドウ エラースキップ> in the <セットアップ> menu to <スル>.

Message	Cause and Remedy
11 XXX ヨウシガアリマセン (xxx indicates abbreviation paper size)	Cause The paper size that is specified from an application is not loaded (when paper source mode is <ジドウ>, this indicates all paper sources, when paper source mode is fixed, this indicates specified paper source). Remedy Load the paper properly.
12 カバーガ アイテイマス	Cause The front cover is open. Remedy Close the front cover firmly. If the printer is not online, press [オンライン].
13 ヨウシガ ツマリマシタ	Cause Paper jam inside the printer. Remedy Remove jammed paper and return the paper cassette and the cover to the original position. If the printer is not online, press [オンライン].

Message	Cause and Remedy
14 トナー/カバー カクニン	<p>Cause The toner cartridge of Y (Yellow), M (Magenta), C (Cyan), or K (Black) is not installed or is not installed properly.</p> <p>Remedy Install the toner cartridge of displayed color, or install it properly.</p>
16 X トナー ヨウイ (X indicates K, Y, M, or C) <Warning message>	<p>Cause The toner cartridge of Y (Yellow), M (Magenta), C (Cyan), or K (Black) is nearing the end of its life.</p> <p>Remedy You can continue printing for a while, however have ready a new toner cartridge. Replace the toner cartridge of displayed color with a new one before printing a large amount of data. After replacing, reset the counter of the toner cartridge.</p>
16 X トナー コウカン (X indicates K, Y, M, or C)	<p>Cause The toner cartridge of Y (Yellow), M (Magenta), C (Cyan), or K (Black) has reached the end of its life.</p> <p>Remedy Press [オンライン]. You can continue printing for a while, however have ready a new toner cartridge. Replace the toner cartridge of displayed color with a new one before printing a large amount of data. After replacing, reset the counter of the toner cartridge.</p>
18 キュウシ エラー	<p>Cause The paper size or paper of the paper type that cannot be fed from the multi-purpose tray or paper cassette is specified.</p> <p>Remedy When specifying the paper source, press [給紙選択] and set <キュウシモード> to <ジドウ>.</p>
16 X トナー コウカン (X indicates K, Y, M, or C)	<p>Cause The toner cartridge of Y (Yellow), M (Magenta), C (Cyan), or K (Black) has reached the end of its life.</p> <p>Remedy Replace the toner cartridge of displayed color with a new one.</p> <p>Cause Toner is solidified on the bottom of the toner cartridge (a message is displayed regardless of replacing a new toner cartridge).</p> <p>Remedy Remove the replaced toner cartridge, hold it with the tab facing down, shake it up and down strongly again, evenly distribute the toner inside the cartridge, and install it.</p>

Message	Cause and Remedy
32 リョウメンインサツ エラー <Error skip>	<p>Cause The paper that cannot be printed in automatic 2-sided printing has been specified.</p> <p>Remedy Set the paper source in this printer and the paper size in an application to the standard paper size, and print again.</p>
41 ヨウシサイズ カクニン	<p>Cause The actual paper size that has been loaded in the multi-purpose tray differs from the setting of <テザシトレイ ヨウシサイズ> that has been selected from an application or the control panel.</p> <p>Remedy Match the paper size that is loaded with <テザシトレイ ヨウシサイズ>, and press [オンライン].</p> <p>Cause In case of LIPS LX printer driver, when setting of <テザシトレイ ヨウシサイズ> or <カセット N (N=2、3、4) ヨウシサイズ> in キュウシ group of セットアップ menu to <フリー>, custom paper of 297.0 mm long or less has been loaded in portrait orientation and printed.</p> <p>Remedy Load it in landscape orientation and print it again.</p>
98 X ドラムコウカン (X indicates K, Y, M, or C)	<p>Cause The drum cartridge of Y (Yellow), M (Magenta), C (Cyan), or K (Black) cannot have been used.</p> <p>Remedy Replace the drum cartridge of displayed color with a new one.</p>
E0 X ドラム ヨウイ (X indicates K, Y, M, or C) <Warning message>	<p>Cause The drum cartridge of Y (Yellow), M (Magenta), C (Cyan), or K (Black) is nearing the end of its life.</p> <p>Remedy You can continue printing for a while, however have ready a new drum cartridge. Replace the drum cartridge of displayed color with a new one before printing a large amount of data.</p>
E1 ハイトナーヨウキ ナシ	<p>Cause The waste toner container is not installed, or is not installed properly.</p> <p>Remedy Install the waste toner container or install it properly.</p>

Message	Cause and Remedy	
E1 ハイトナーヨウキ ヨウイ <Warning message>	Cause	The waste toner container needs to be replaced soon.
	Remedy	You can continue to print for a while, however have ready a new waste toner container.
E1 ハイトナーヨウキ コウカン	Cause	The waste toner container has been full.
	Remedy	Replace the waste toner container with a new one.
E2 X ドラム ナシ (X indicates K, Y, M, or C)	Cause	The drum cartridge of Y (Yellow), M (Magenta), C (Cyan), or K (Black) is not installed or is not installed properly.
	Remedy	Install the drum cartridge of displayed color, or install it properly.
E5 ティチャクキ ヨウイ <Warning message>	Cause	The fixing unit is nearing the end of its life.
	Remedy	You can continue to print for a while, however have ready a new fixing unit.
E7 ティチャクキ カクニン	Cause	Fixing unit is not installed, or is not installed properly.
	Remedy	Install the Fixing unit, or install it properly.
EF X ドラム コウカン (X indicates K, Y, M, or C) <Error skip>	Cause	The drum cartridge of Y (Yellow), M (Magenta), C (Cyan), or K (Black) has reached the end of its life.
	Remedy	Press [オンライン]. You can continue to print for a while, however, as this may result in deterioration in print quality. Replace the drum cartridge with a new one. After replacing, if the printer is not online, press [オンライン].
98 X ドラムコウカン (xxx indicates abbreviation paper size)	Cause	The paper size that is selected in an application is not loaded in the paper cassette or the multi-purpose tray, or the paper source of the different paper size is selected.
	Remedy	Load the paper of size that is set in an application (or scaling) in the selected paper cassette.