

Canon

Laser Beam Printer

Satera LBP 3970/3920

User's Guide

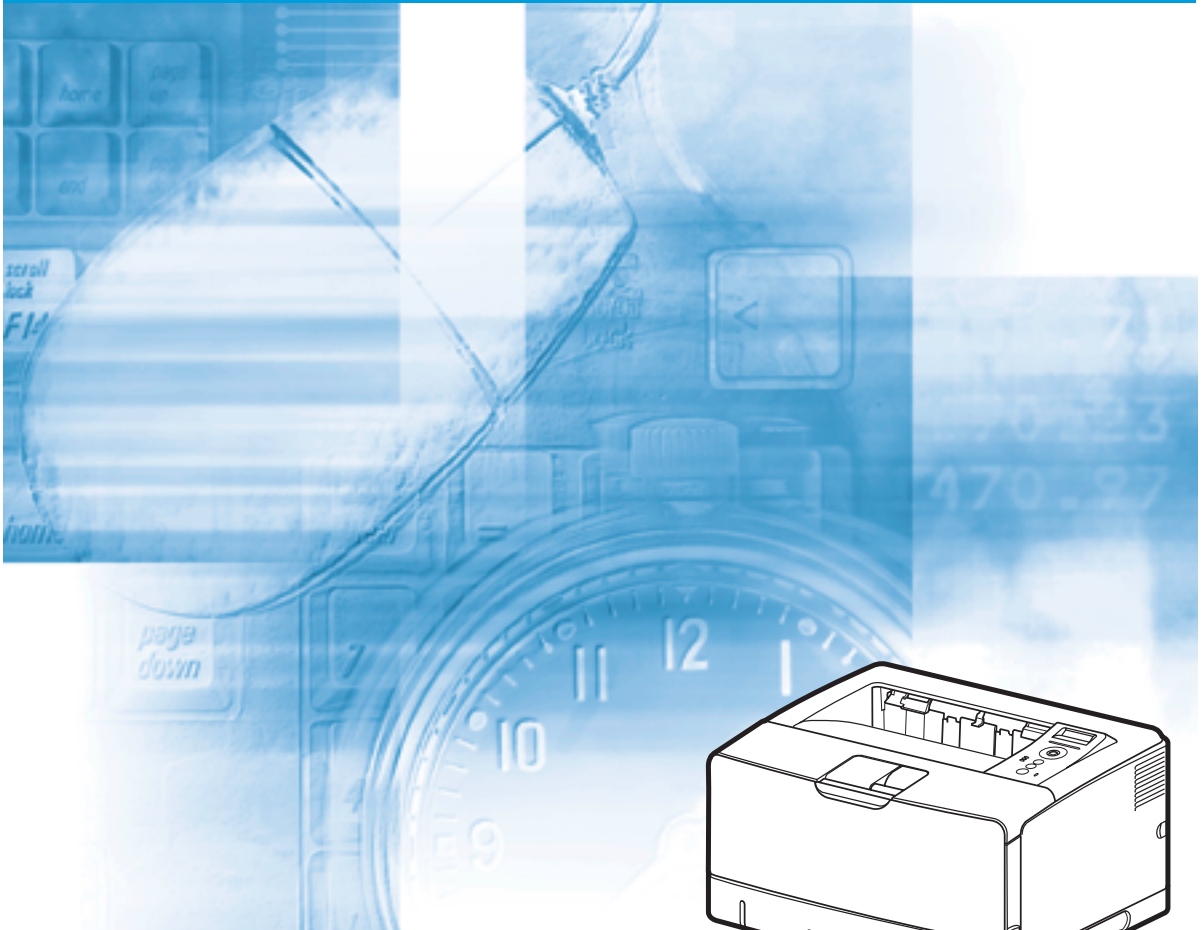

Contents

Turning the Printer ON/OFF	2
Turning the Printer ON	2
Turning the Printer OFF	3
Online and Offline	5
Placing the Printer Online	5
Placing the Printer Offline	6
Paper Requirements	7
Usable Paper	7
Paper Size/Type	8
Abbreviations of Paper Sizes	14
Printable Area	14
Unusable Paper	16
Paper Capacity of Paper Source	17
Paper Capacity of the Output Trays	18
Loading Paper in the Paper Cassette	19
When Loading Standard Size Paper	19
When Loading Custom Size Paper (Non-Standard Size Paper)	27
Loading Paper in the Multi-purpose Tray	36
When Loading Paper (Other than Postcards and Envelopes)	36
When Loading Postcards or Envelopes	43
Paper Jams	50
Paper Jam Area	53
Procedure for Clearing Paper Jams	54
Replacing the Toner Cartridge	75
When < トナー ヨウイ/カクニン > Appears	75
Replacing the Toner Cartridge	76
Canceling a Job	86
Confirming the Printer Features	87
Service Call Display	89
Message List	91

Turning the Printer ON/OFF

The printer can be turned ON/OFF using the power switch on the right side of the printer body. Be sure to observe the following instructions in order to prevent unexpected problems.

Turning the Printer ON

In order to use this printer, you should press "I" of the power switch to turn the printer ON. After running a self-diagnostic test on the printer unit and optional accessories, the printer will be ready to print.

IMPORTANT

Do not turn the power ON immediately after turning it OFF. If you want to turn the printer ON again after turning it OFF, wait at least 10 seconds after turning the printer OFF before turning it ON again.

1 Press "I" of the power switch on the printer.

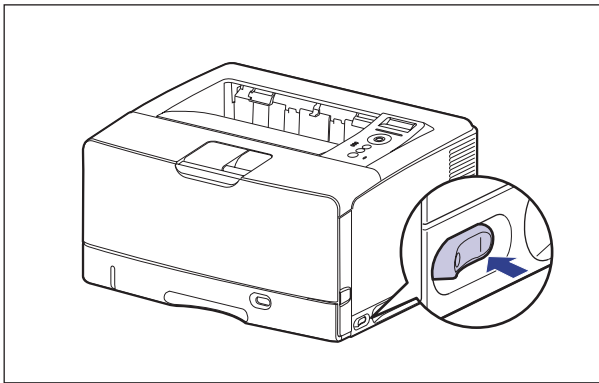

The indicators and display on the control panel come on, and the printer initiates a self-diagnostic test on the printer unit and optional accessories.

If no abnormality is found during the self-diagnostic test, the オンライン indicator, 印刷可 indicator and Paper Source indicator for the currently selected paper source come on, <00 インサツ カノウ>, <00 LIPS>, or <00 ESC/P> appears in the display, and the printer is ready to print.

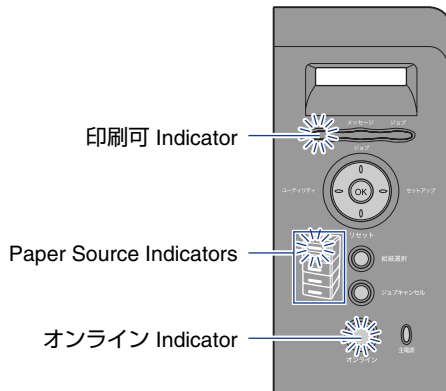

The following information is displayed in the display.

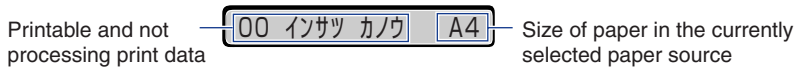

Turning the Printer OFF

Turn the printer OFF using the following procedure.



IMPORTANT

- If the printer is used on a network, make sure that it is not printing data from another computer before turning the power OFF.
- If you turn the printer OFF when the ジョブ indicator is on, all the print data remaining in the printer memory will be erased. If there is any necessary print data remaining in the printer, wait until it is output, or press [リセット] in the offline state and then select <ハイ シュツ> to output the data before turning the printer OFF.
- Do not turn the power OFF when the printer is in any of the following status:
 - While the printer is in the middle of printing
 - While the printer is running a self-diagnostic test immediately after turning the power ON
 - While a message informing you that the NVRAM is being initialized or being written is displayed
 - While <02 キドウチュウ> is displayed

1 Make sure that the ジョブ indicator is off.

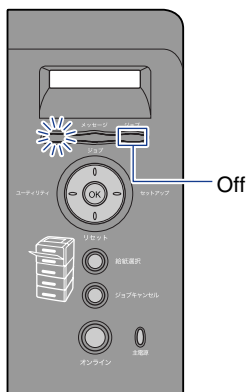

2 Press "○" of the power switch on the printer.

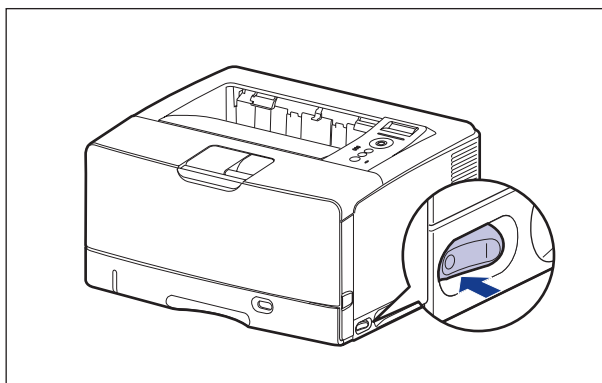

Online and Offline

When the printer can receive data from the computer and print the data, the printer is in the state of "Online", and when the printer is disconnected with the computer and cannot receive data, the printer is in the state of "Offline".

To perform the settings for each menu using the control panel, switch the printer status as follows:

○: The status that you can enter the menu

-: The status that you cannot enter the menu

	When the printer is online	When the printer is offline
セットアップ Menu	○*	○
キューシ センタク Menu	○	○
リセット Menu	○	○
ジョブ Menu	○	-
ユーティリティ Menu	○	-

* You cannot specify the settings in the ユーザメンテナンス options when the printer is in the online status.

Placing the Printer Online

When printing from the computer, the printer has to be online. Before printing, make sure that the printer is online. If not, place the printer online using the following procedure. The printer comes online automatically after you turn it ON.



1 Press [オンライン].

The オンライン indicator comes on, and the printer is ready to print.



IMPORTANT

When an error is occurring in the printer (when the メッセージ indicator is on, or the number in the message blinks), the printer does not come online. Eliminate the cause of the error before you place the printer online.

 NOTE

If the printer has entered the sleep mode 1 or sleep mode 2, the オンライン indicator is off even when the printer is online, and only the 印刷可 indicator and 主電源 indicator are on. If the printer has entered the sleep mode 3, only the 主電源 indicator is on. If the printer receives data while it is in the sleep mode, the mode is released, the オンライン indicator comes on, and the printer is ready to print. However, if the printer has entered the sleep mode 3, the mode is not released even after the printer receives data from the computer connected by a USB cable.

Placing the Printer Offline

To configure the printer so that it does not receive data from the computer or specify the settings for all the options in the セットアップ menu, place the printer offline using the following procedure.



1 Press [オンライン].

The オンライン indicator goes off, allowing you to specify the settings on the control panel.



IMPORTANT

This printer comes online automatically if left in the offline state for five minutes or longer. However, when an error is occurring in the printer (when the メッセージ indicator is on, or the number in the message blinks), or while you are performing any setting, such as selecting the menu functions or a paper source, or when specifying the paper size, the printer does not come online.



Paper Requirements

Usable Paper

To ensure optimum performance, use only paper that falls within the specifications in the following lists. Using inappropriate paper may result in deterioration in print quality or paper jams.



IMPORTANT

- Print speed may drop depending on the settings for the paper orientation, paper size, paper type and total print pages.
- When continuously printing the paper of A4 size (297.0 mm wide) or smaller, the safety function that prevents damages caused by heat may slow the print speed down in stages. (The print speed may be as slow as approximately 1.9 pages/minute.)

Paper Size/Type

The following shows the paper sizes that can be used with this printer. The symbol "●" indicates the paper that can be used for 1-sided printing and automatic 2-sided printing using the optional duplex unit, the symbol "○" indicates the paper that can be used for only 1-sided printing, and the symbol "-" indicates the paper that cannot be used.

Paper Type	Paper Source				
	Multi-purpose Tray	Cassette 1	Cassette 2 (Optional)	Cassette 3*1 (Optional)	Cassette 4*1 (Optional)
Plain paper (60 - 90 g/m ²)	●	●	●	●	●
A5*2					
B5*2	●	●	●	●	●
A4	●	●	●	●	●
B4*3	●	●	●	●	●
A3*3	●	●	●	●	●
Letter	●	●	●	●	●
Executive*2	●	●	●	●	●
Legal*3	●	●	●	●	●
Ledger (11 x 17)*3	●	●	●	●	●
Custom paper size	●*4	●*5	●*6	●*6	●*6
Postcard*3 100.0 mm x 148.0 mm	○	-	-	-	-
Reply postcard*2 148.0 mm x 200.0 mm	○	-	-	-	-
4 on 1 postcard*2 200.0 mm x 296.0 mm	○	-	-	-	-

Paper Type	Paper Source				
	Multi-purpose Tray	Cassette 1	Cassette 2 (Optional)	Cassette 3* ¹ (Optional)	Cassette 4* ¹ (Optional)
Heavy paper (91 - 199 g/m ²) A5 - Ledger (11 x 17)	○	-	-	-	-
Custom paper size	○* ⁴	-	-	-	-
Postcard* ³ 100.0 mm x 148.0 mm	○	-	-	-	-
Reply postcard* ² 148.0 mm x 200.0 mm	○	-	-	-	-
4 on 1 postcard* ² 200.0 mm x 296.0 mm	○	-	-	-	-
Transparency A4	○	-	-	-	-
Label A4	○	-	-	-	-
Postcard* ³ 100.0 mm x 148.0 mm	○	-	-	-	-
Reply postcard* ² 148.0 mm x 200.0 mm	○	-	-	-	-
4 on 1 postcard* ² 200.0 mm x 296.0 mm	○	-	-	-	-
Envelope* ³ YOUGATA No. 4 105.0 mm x 235.0 mm	○	-	-	-	-
YOUGATA No. 2 114.0 mm x 162.0 mm	○	-	-	-	-
KAKUGATA No. 2 240.0 mm x 332.0 mm	○	-	-	-	-

*1 Cassette 3 and Cassette 4 can be installed only in LBP3970.

*2 Paper can be loaded only in landscape orientation.

*3 Paper can be loaded only in portrait orientation.

*4 You can load paper of the following custom paper sizes.

- When loading paper in portrait orientation: Width 90.0 to 312.0 mm; Length 148.0 to 470.0 mm
- When loading paper in landscape orientation (only when LIPS LX Printer Driver is used): Width 148.0 to 312.0 mm; Length 148.0 to 312.0 mm

You can perform automatic 2-sided printing on paper (plain paper) of the following custom paper sizes.

- When loading paper in portrait orientation: Width 210.0 to 297.0 mm; Length 210.0 to 431.8 mm
- When loading paper in landscape orientation (only when LIPS LX Printer Driver is used): Width 210.0 to 297.0 mm; Length 148.0 to 297.0 mm

*5 You can load paper of the following custom paper sizes.

- When loading paper in portrait orientation: Width 210.0 to 297.0 mm; Length 210.0 to 431.8 mm*
- * If the paper width is 279.5 to 297.0 mm, the paper length should be 210.0 to 420.0 mm.
- When loading paper in landscape orientation (only when LIPS LX Printer Driver is used): Width 210.0 to 297.0 mm; Length 148.0 to 297.0 mm

*6 You can load paper of the following custom paper sizes.

- When loading paper in portrait orientation: Width 210.0 to 297.0 mm; Length 210.0 to 431.8 mm
- When loading paper in landscape orientation (only when LIPS LX Printer Driver is used): Width 210.0 to 297.0 mm; Length 148.0 to 297.0 mm

■ Plain Paper

This printer can print plain paper at sizes of A3, B4, A4, B5, A5, Ledger (11 x 17), Legal, Letter, Executive, Postcard, Reply postcard, 4 on 1 postcard, and custom paper sizes that weighs between 60 and 90 g/m².

Plain paper can be loaded in the paper cassettes and multi-purpose tray. Also, paper at sizes of A3, B4, A4, B5, A5, Ledger (11 x 17), Letter, Legal, Executive, and paper of the following custom paper sizes are available for automatic 2-sided printing.

When loading paper in portrait orientation: Width 210.0 to 297.0 mm; Length 210.0 to 431.8 mm

When loading paper in landscape orientation (only when LIPS LX Printer Driver is used): Width 210.0 to 297.0 mm; Length 148.0 to 297.0 mm

■ Heavy Paper

This printer can print heavy paper at sizes of A3, B4, A4, B5, A5, Ledger (11 x 17), Legal, Letter, Executive, Postcard, Reply postcard, 4 on 1 postcard, and custom paper sizes that weighs between 91 and 199 g/m². Heavy paper can be loaded in the multi-purpose tray, and is available only for 1-sided printing.

■ Transparency

This printer can print A4 size transparencies. Transparencies can be loaded in the multi-purpose tray.



IMPORTANT

- Use "A4 size transparencies for LBP recommended by Canon". "A4 size transparencies for LBP recommended by Canon" weighs 8.7 g per sheet.
- Thoroughly fan the transparencies before loading them as they may stick to each other.

■ Label

This printer can print A4 size labels. Labels can be loaded in the multi-purpose tray.

IMPORTANT

- Use "A4 size labels recommended by Canon". "A4 size labels recommended by Canon" weighs 7.8 g per sheet.
- Do not use the labels in the following conditions. Using inappropriate labels may result in paper jams that are difficult to clear or may result in damage to the printer.
 - Peeled labels or partly used labels
 - Coated labels that are easily peeled off from the backing sheet
 - Labels with uneven adhesive

■ Postcard/Reply postcard/4 on 1 postcard

This printer can print postcards, reply postcards, 4 on 1 postcards, and 4 on 1 postcards recommended by Canon. Load postcards, reply postcards, and 4 on 1 postcards in the multi-purpose tray with the printing side facing up.

IMPORTANT

- Printing inappropriate size postcards (other than Postcard, Reply postcard, 4 on 1 postcard, and 4 on 1 postcard recommended by Canon) may result in deterioration in print quality or paper jams.
- You cannot print reply postcards with folds.
- If the post cards are curled, flatten the curls by warping them in the opposite direction before loading them.
- Postcards and reply postcards for ink jet printers cannot be printed.
- Postcards cannot be loaded in landscape orientation. Be sure to load them in portrait orientation with the printing side facing up.
(← : Feeding direction)

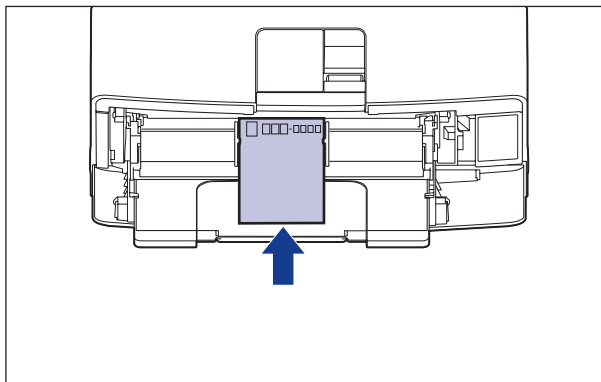

- Reply postcards and 4 on 1 postcards cannot be loaded in portrait orientation. Be sure to load them in landscape orientation with the printing side facing up.
(← : Feeding direction)

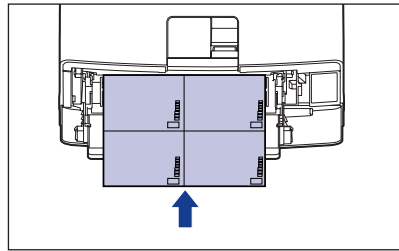
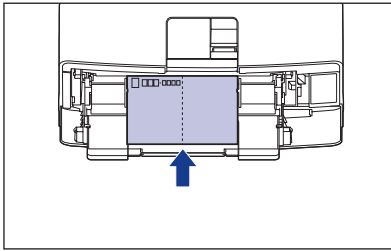

- Printing speed drops when printing postcards, reply postcards, or 4 on 1 postcards.

■ Envelope

The envelopes that can be used with this printer are YOUGATA No. 4, YOUGATA No. 2, and KAKUGATA No. 2 with the following structures only. Load the envelopes with the address side (non-glued side) facing up in the multi-purpose tray.

YOUGATA No. 4
(105 mm × 235 mm)

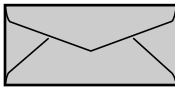

YOUGATA No. 2
(114 mm × 162 mm)

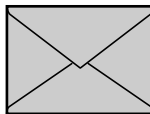

KAKUGATA No. 2
(240 mm × 332 mm)
(Envelope K-201G for
Canon LBP/recommended)

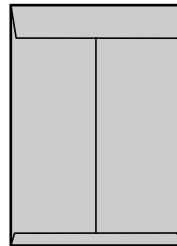

* You cannot use envelopes at sizes of YOUGATA No. 4 and YOUGATA No. 2 that have a flap on the short edge.

👉 IMPORTANT

- Do not use the following types of envelopes. Using inappropriate envelopes may result in paper jams that are difficult to clear or may result in damage to the printer.
 - Envelopes with fasteners or snaps
 - Envelopes with address windows
 - Envelopes with adhesive on the surface
 - Wrinkled or creased envelopes
 - Poorly manufactured envelopes in which the glued parts are uneven
 - Irregularly-shaped envelopes
- Before loading the envelopes, flatten the stack of envelopes to release any remaining air, and press the fold lines along the edges tight.
- Do not print on the reverse side (glued side) of envelopes.

- When loading envelopes at a size of YOUNGATA No. 4 or YOUNGATA No. 2, load them so that the flap is toward the left of the printer when viewed from the front.
(← : Feeding direction)

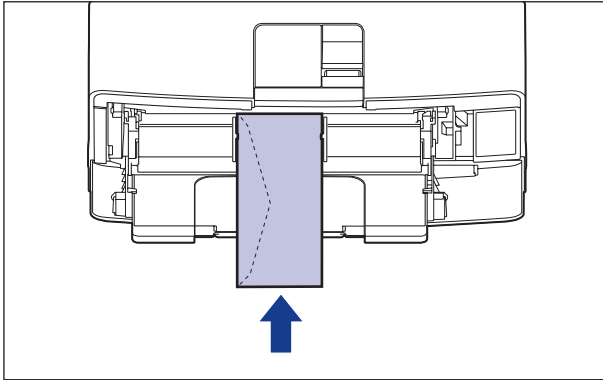

- When loading envelopes of the KAKUGATA No. 2 size, leave the flaps open and load them so that the bottom of the envelopes is toward the back of the printer when viewed from the front.
(← : Feeding direction)

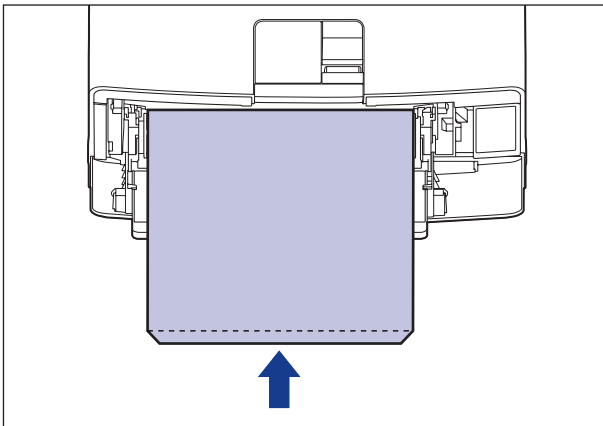

- Printing speed drops when printing envelopes.

 NOTE

When printing envelopes, they may be creased.

Abbreviations of Paper Sizes

The following shows the abbreviations of paper sizes that are marked on the paper cassette:

Paper Size	Abbreviations on the Paper Cassette
Ledger (11 x 17)	11 x 17
Legal	LGL
Letter	LTR
Executive	EXEC
Custom paper size	Custom

Printable Area

The following shows the printable area of this printer: However, if you have selected the [Print with Upper Left of Sheet as Starting Point] check box in the [Finishing Details] dialog box in the LIPS printer driver, you can extend the printable area to near the edges of the paper. For more details, see Help of the printer driver.

■ Plain Paper/Heavy Paper/Transparency/Label

You cannot print on any area within 5 mm of the edges of paper.

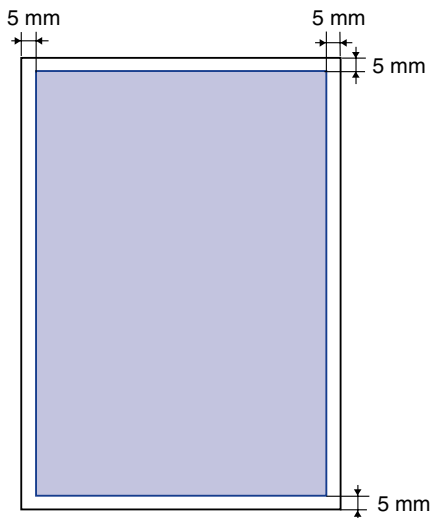

■ Postcard/Reply Postcard/4 on 1 Postcard

You cannot print on any area within 5 mm of the edges of a postcard.

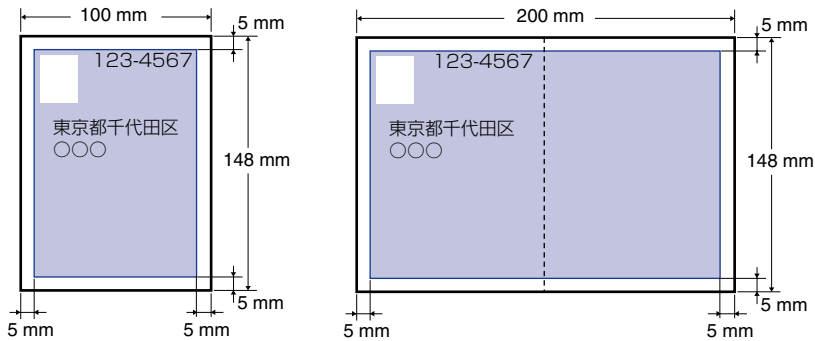

IMPORTANT

You may not obtain the optimum print quality when printing postcard data with no margin. It is recommended that you specify the size of the data a little smaller than the printable area for the postcard size.

■ Envelope

You cannot print on any area within 10 mm of the edges of an envelope.

You may have to change the printable area before printing, depending on the application you use.

(Sample: Envelope YOUGATA No. 4)

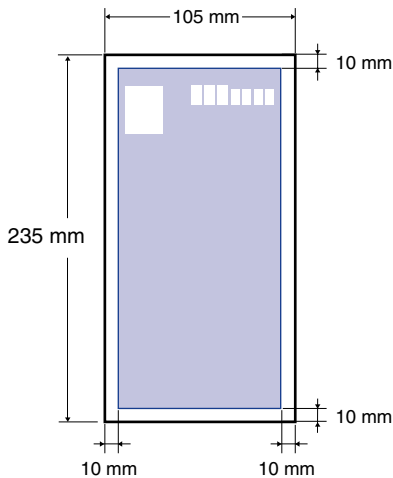

IMPORTANT

When you print envelopes, a part of the printed zip code may be missing. In this case, you can print the envelopes without any part of the zip code missing by selecting the [Print with Upper Left of Sheet as Starting Point] check box or [Expand Print Region and Print] check box.

Unusable Paper

To avoid problems such as paper jams and other malfunctions, the following types of paper should never be used:



IMPORTANT

- Paper that jams easily
 - Paper that is too thick or too thin
 - Irregularly-shaped paper
 - Wet or moist paper
 - Torn or damaged paper
 - Rough, extremely smooth, or glossy paper
 - Paper with binding holes or perforations
 - Curled or creased paper
 - Specially coated paper (coated paper for ink jet printers, etc.)
 - Labels with backing sheet that is easily peeled off
 - Paper that has already been printed by a copy machine or another laser printer (The reverse side of the paper is also unusable. Using the multi-purpose tray, however, you can perform 2-sided printing manually on the other side of previously printed paper. You cannot print on the printed side again.)
 - Paper with jagged edges
 - Wrinkled paper
 - Paper with the corners folded
- Paper that changes its quality at a high temperature
 - Paper that contains ink that melts, burns, evaporates or emits harmful gases at a temperature lower than the heating temperature (approx. 270 °C) of the fixing unit
 - Heat-sensitive paper
 - Treated color paper
 - Specially coated paper (coated paper for ink jet printers, etc.)
 - Paper with adhesive on the surface
- Paper that causes printer malfunctions or damages the printer
 - Carbon paper
 - Paper with staples, clips, ribbons or tapes
 - Paper that has already been printed by a copy machine or another laser printer (The reverse side of the paper is also unusable. Using the multi-purpose tray, however, you can perform 2-sided printing manually on the other side of previously printed paper. You cannot print on the printed side again.)
- Paper that is difficult for the toner to fix onto
 - Paper with rough surfaces
 - Specially coated paper (coated paper for ink jet printers, etc.)
 - Paper containing thick fibers

Paper Capacity of Paper Source

Paper Type	Paper Source				
	Multi-purpose tray	Cassette 1	Cassette 2 (Optional)	Cassette 3* (Optional)	Cassette 4* (Optional)
Plain paper (Ex. 64 g/m ²)	Approx. 100 sheets	Approx. 250 sheets	Approx. 500 sheets	Approx. 500 sheets	Approx. 500 sheets
Heavy paper (Ex. 128 g/m ²)	Approx. 50 sheets	-	-	-	-
Transparency	Approx. 50 sheets	-	-	-	-
Label	Approx. 40 sheets	-	-	-	-
Postcard	Approx. 40 sheets	-	-	-	-
Reply postcard	Approx. 40 sheets	-	-	-	-
4 on 1 postcard	Approx. 40 sheets	-	-	-	-
4 on 1 postcard recommended by Canon	Approx. 40 sheets	-	-	-	-
Envelope	Approx. 10 sheets	-	-	-	-

* Cassette 3 and Cassette 4 can be installed only in LBP3970.

Paper Capacity of the Output Trays

Paper Type	Output Trays*	
	Output Tray	Sub-output Tray
Plain paper (Ex. 64 g/m ²)	Approx. 250 sheets	Approx. 50 sheets
Heavy paper (Ex. 128 g/m ²)	Approx. 150 sheets	Approx. 30 sheets
Transparency	Approx. 100 sheets	1 sheet
Label	Approx. 100 sheets	Approx. 20 sheets
Postcard	Approx. 100 sheets	Approx. 20 sheets

Paper Type	Output Trays*	
	Output Tray	Sub-output Tray
Reply postcard	Approx. 100 sheets	Approx. 20 sheets
4 on 1 postcard	Approx. 100 sheets	Approx. 20 sheets
4 on 1 postcard recommended by Canon	Approx. 100 sheets	Approx. 20 sheets
Envelope	Approx. 50 sheets	Approx. 10 sheets

* Actual paper capacity varies depending on the installation environment and paper type.

Loading Paper in the Paper Cassette

Load paper in the paper cassette. The paper loading methods are different between standard size paper and custom size paper. Therefore, load paper properly using the following procedures.

- When Loading Standard Size Paper (See p. 19)
- When Loading Custom Size Paper (Non-Standard Size Paper) (See p. 27)



IMPORTANT

For more details on the usable paper, see "Usable Paper," on p. 7.



NOTE

Load paper in the optional 250-sheet universal cassette UC-67D in the same manner as you load paper in Cassette 1.

Load paper in the optional 500-sheet universal cassette UC-67KD in the same manner as you load paper in Cassette 2, 3, and 4.

When Loading Standard Size Paper

Perform the following procedure to load standard size paper.

Load paper in portrait or landscape orientation. Depending on the size of the paper to be loaded, the loading orientation differs as follows:

- Cassette 1

Portrait orientation

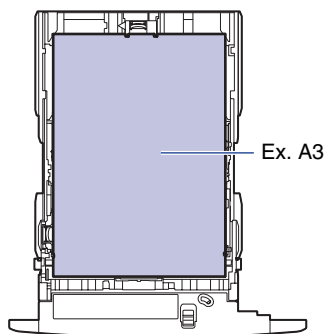

Landscape orientation

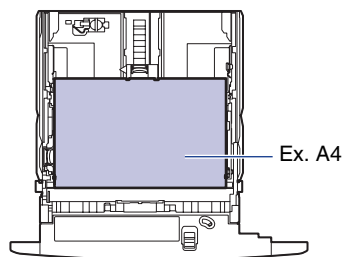

Paper that can be loaded in landscape orientation:
A4, B5, A5, Letter, Executive

Paper that can be loaded in portrait orientation:
A3, B4, A4R, Ledger (11 x 17), Legal, LetterR

• Cassette 2, 3, and 4

Portrait orientation

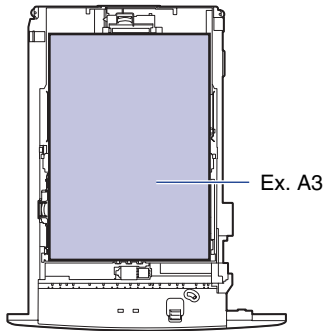

Landscape orientation

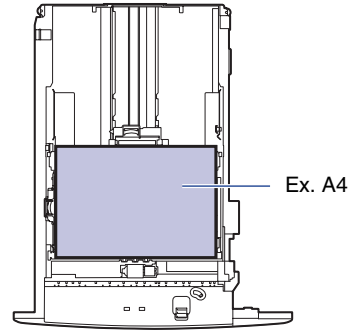

Paper that can be loaded in portrait orientation:
A3, B4, A4R, Ledger (11 x 17), Legal, LetterR

Paper that can be loaded in landscape orientation:
A4, B5, A5, Letter, Executive

1 Pull out the paper cassette.

Cassette 1

Pull out the paper cassette gently until it stops ①.

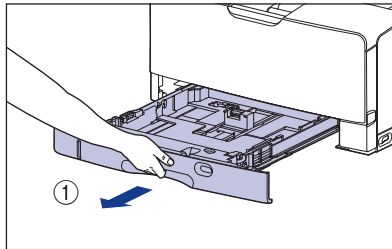

Cassette 2, 3, and 4

Pull out the paper cassette gently until it stops ①.

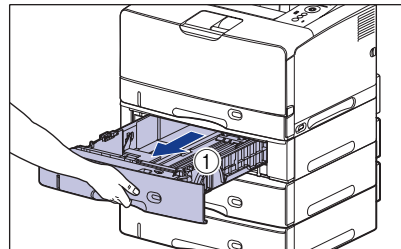

Raise the front side of the paper cassette and remove it from the printer ②.

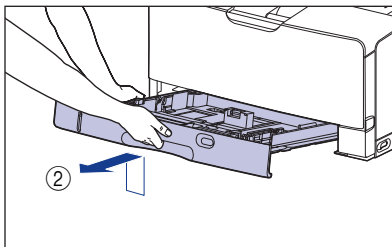

Hold the grips (A) with both hands, raise the front side of the paper cassette slightly ②, and then pull it out completely ③ as shown in the figure.

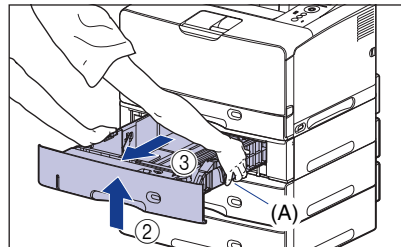

CAUTION

Be sure to take the paper cassette out of the printer before loading paper. If paper is loaded while the paper cassette is partially pulled out, the paper cassette may drop or the printer may become damaged resulting in personal injury.

IMPORTANT

- The paper cassette cannot be pulled out horizontally. If you try to pull it out forcefully, this may result in damage to the paper cassette.
- Hold the paper cassette with both hands securely because the cassette is heavy.
- Place the removed paper cassette on a flat and stable surface.

2 When changing the size of the paper to be loaded, adjust the length of the paper cassette and change the positions of the paper guides.

● When loading paper in Cassette 1, adjust the length of the paper cassette according to the paper to be loaded.

When loading paper at sizes of A4, B5, A5, Letter, and Executive, shorten the paper cassette.

When loading paper at sizes of A3, B4, A4R, Ledger (11 x 17), Legal, and LetterR, extend the paper cassette.

To adjust the length of the paper cassette, align the lock release lever with "Ⓔ" to release the lock, slide the paper cassette by holding the rear portion of the paper cassette, and then align the lock release lever with "Ⓕ" to lock the cassette.

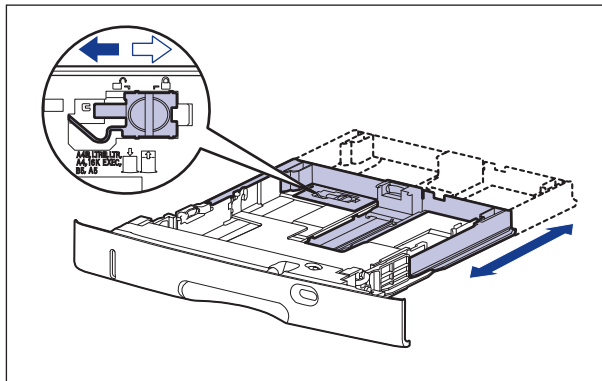

- While holding the lock release lever of the side paper guides, slide the guides to the size mark for the paper to be loaded.

The side paper guides move together. Align the position of (A) with the size mark for the paper to be loaded.

Cassette 1

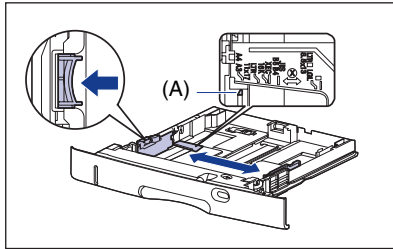

Cassette 2, 3, and 4

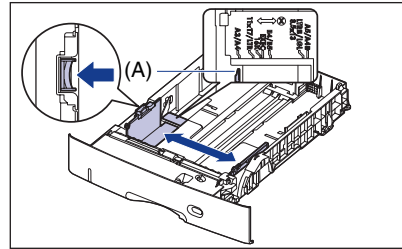

 **IMPORTANT**

Do not use the "16K" and "8.5 x 13" position.

- While holding the lock release lever of the rear paper guide, slide the guide to the size mark for the paper to be loaded.

Align the position of (A) with the size mark for the paper to be loaded.

Cassette 1

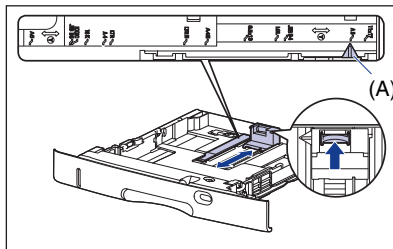

Cassette 2, 3, and 4

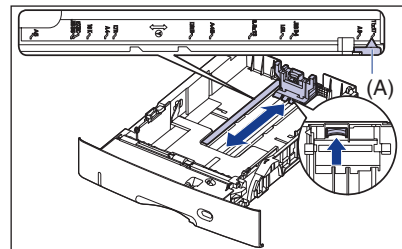

 **IMPORTANT**

Do not use the "16K" and "8.5 x 13" position.

3 Load the paper stack so that the rear edge is aligned with the paper guide.

Cassette 1

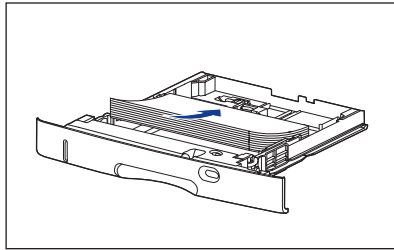

Cassette 2, 3, and 4

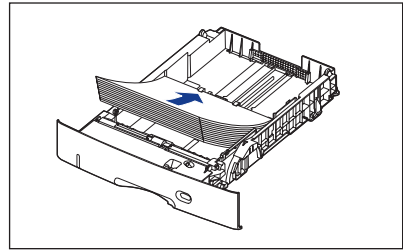

CAUTION

When loading paper, take care not to cut your hands with the edges of the paper.

IMPORTANT

- Be sure to check if the paper guide is at the position of the size of the loaded paper. If the paper guide is set at a wrong position, this may result in misfeeds.
- If you use paper that has been poorly cut, multiple sheets of paper may be fed at once. In this case, fan the paper thoroughly, and then align the edges of the stack on a hard, flat surface.

NOTE

To print letterhead paper or paper printed with a logo, load the paper in the proper orientation according to the following instructions:

( : Feeding direction)

- When loading paper at a size of A4, B5, A5, Letter, or Executive in landscape orientation, load the paper so that the printing side is facing down, as shown in the following figures.

Cassette 1

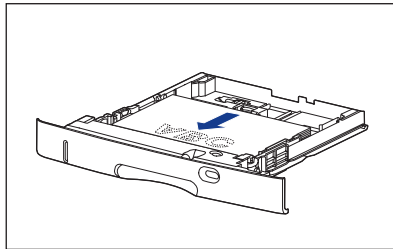
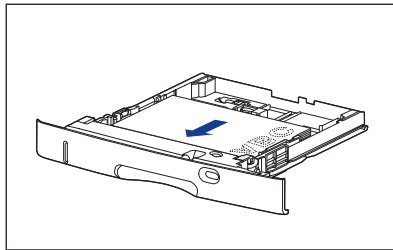

Cassette 2, 3, and 4

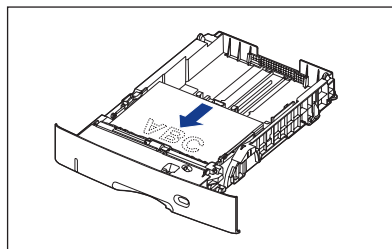
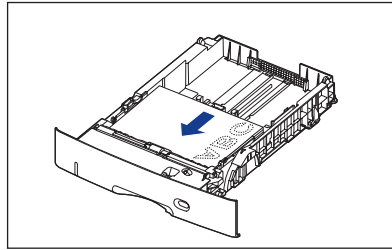

- When loading paper at a size of A3, B4, A4R, Ledger (11 x 17), Legal, or LetterR in portrait orientation, load the paper so that the printing side is facing down, as shown in the following figures.

Cassette 1

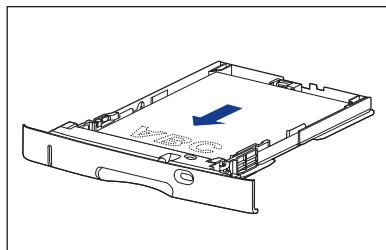
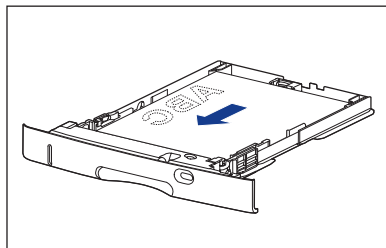

Cassette 2, 3, and 4

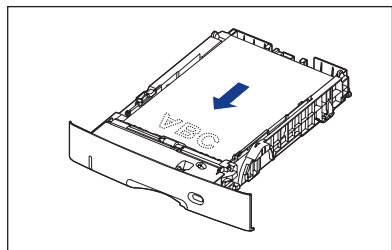
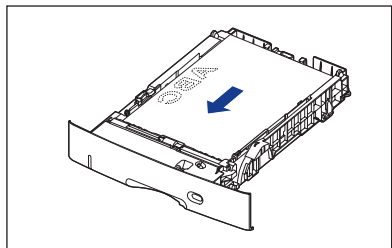

4 Hold down the paper as shown in the figure, make sure that the paper stack does not exceed the load limit marks (A), and then set it under the hooks (B) on the paper guides.

Make sure that there is sufficient space between the hooks of the paper guides and the paper stack. If there is no sufficient space, slightly reduce the amount of paper.

Cassette 1

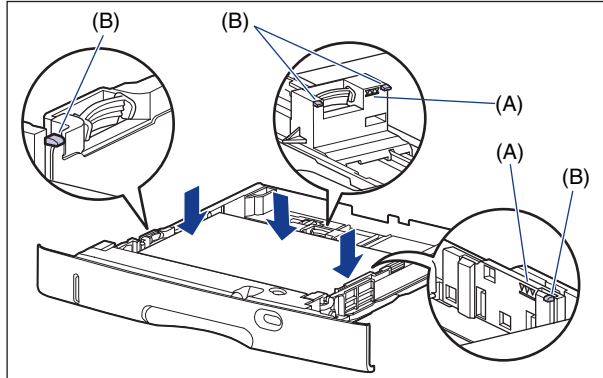

Cassette 2, 3, and 4

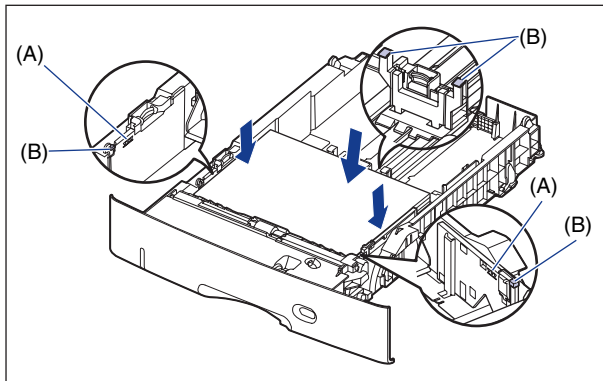

 **IMPORTANT**

The paper capacity of Cassette 1 is approximately 250 sheets of plain paper (64 g/m²), and that of Cassette 2, 3, and 4 is approximately 500 sheets of plain paper (64 g/m²). Be sure that the paper stack does not exceed the load limit marks on the paper guides. If the paper stack exceeds the load limit marks, this may result in misfeeds.

5 When changing the size of the paper to be loaded, set the paper size setting switch and paper size register dial to the size of the loaded paper.

- Holding the tab of the paper size setting switch, set the paper size setting switch (A) to the size of the loaded paper.

Cassette 1

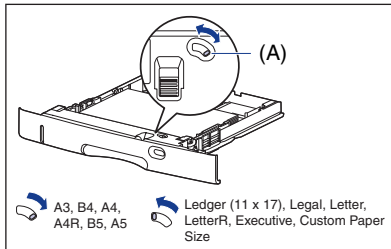

Cassette 2, 3, and 4

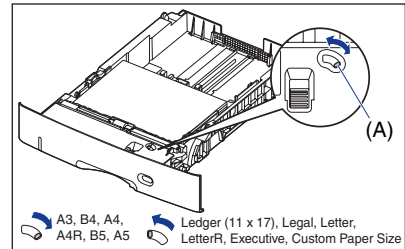

- Adjust the paper size register dial (B) to set the dial to the size of the loaded paper.

Cassette 1

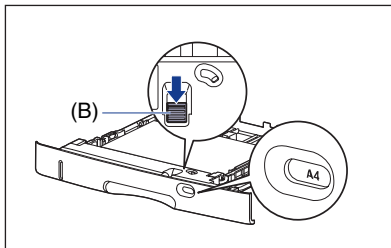

Cassette 2, 3, and 4

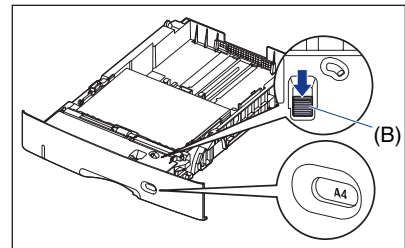

IMPORTANT

- Make sure that the paper size the paper size register dial is indicating corresponds with the size of the loaded paper before setting the paper cassette in the printer. If the paper size that the paper size register dial is indicating does not correspond with the size of the loaded paper, this may result in printer malfunction.
- Do not use the "16K" and "8.5 x 13" position.

6 Set the paper cassette in the printer at an angle as shown in the figure ①, then push it into the printer or paper feeder gently and horizontally ②.

Push the paper cassette into the printer firmly until the front side of the paper cassette is flush with the front surface of the printer.

Cassette 1

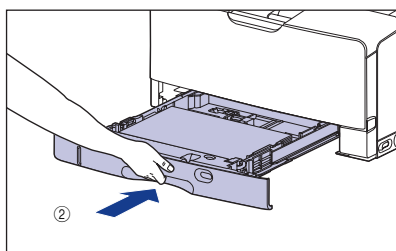
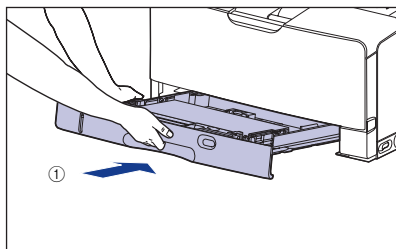

Cassette 2, 3, and 4

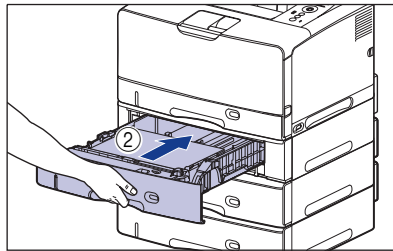
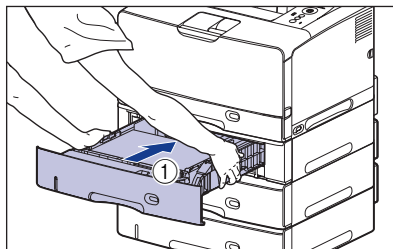

CAUTION

When setting the paper cassette in the printer, be careful not to catch your fingers.

When Loading Custom Size Paper (Non-Standard Size Paper)

Perform the following procedure to load custom size paper.



IMPORTANT

- You can load paper of the following custom paper sizes.
 - When loading paper in portrait orientation: Width 210.0 to 297.0 mm; Length 210.0 to 431.8 mm*
 - * When loading paper that is 279.5 to 297.0 mm wide in Cassette 1, the paper length should be 210.0 to 420.0 mm.
 - When loading paper in landscape orientation (only when LIPS LX Printer Driver is used): Width 210.0 to 297.0 mm; Length 148.0 to 297.0 mm
- When custom size paper is loaded, specify the setting for <カセット N (N=1、2、3*、4*) ヨウシサイズ > as follows.
 - * Can be specified only with LBP3970.

- When the paper is loaded in landscape orientation (only when LIPS LX Printer Driver is used): < ユーザセッテイサイズ >
- When the paper is loaded in portrait orientation: < ユーザセッテイサイズ R >
- When you change the orientation of the loaded custom size paper frequently, it is convenient if you set < カセット N (N=1、2、3*、4*) ヨウシサイズ > to < フリー >. When < カセット N (N=1、2、3*、4*) ヨウシサイズ > is set to < フリー >, you do not need to change the setting for < カセット N (N=1、2、3*、4*) ヨウシサイズ > each time you change the paper orientation. However, if you specify < フリー >, make sure that the size of the loaded paper matches the paper size specified in the printer driver before printing. If they do not match, the printer may stop printing, displaying the message < 41 ヨウシサイズ カクニン >, or a paper jam may occur. Be sure to check if the paper size specified in the printer driver matches the size of the paper loaded in the paper cassette before using the printer. However, if < トクシュモード J > is set to < ツカウ >, the printer prints without checking the paper size even when the paper size specified in the printer driver and the size of the paper loaded in the paper cassette do not match.
 - * Can be specified only with LBP3970.
- When custom size paper is printed from LIPS LX Printer Driver, you can load the paper either in portrait or landscape orientation. However, when you are printing custom size paper of its long edges 297.0 mm or less with < カセット N (N=1、2、3、4) ヨウシサイズ > set to < フリー >, load the paper in landscape orientation. When you are not printing from LIPS LX Printer Driver, load the paper in portrait orientation.

1 Pull out the paper cassette.

Cassette 1
Pull out the paper cassette gently until it stops ①.

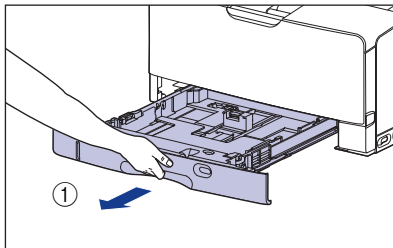

Cassette 2, 3, and 4
Pull out the paper cassette gently until it stops ①.

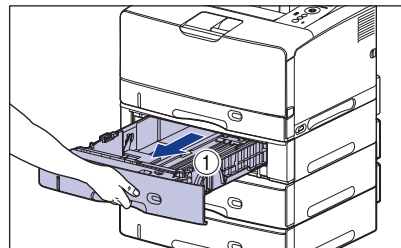

Raise the front side of the paper cassette and remove it from the printer ②.

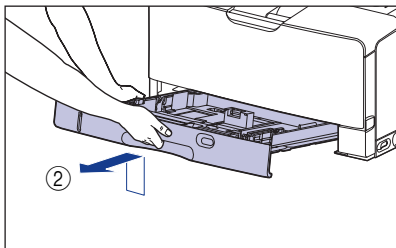

Hold the grips (A) with both hands, raise the front side of the paper cassette slightly ②, and then pull it out completely ③ as shown in the figure.

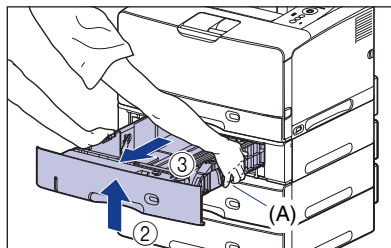

⚠ CAUTION

Be sure to take the paper cassette out of the printer before loading paper. If paper is loaded while the paper cassette is partially pulled out, the paper cassette may drop or the printer may become damaged resulting in personal injury.

👉 IMPORTANT

- The paper cassette cannot be pulled out horizontally. If you try to pull it out forcefully, this may result in damage to the paper cassette.
- Hold the paper cassette with both hands securely because the cassette is heavy.
- Place the removed paper cassette on a flat and stable surface.

2 When loading paper that is longer than A4 size (297.0 mm long) in Cassette 1, adjust the length of the paper cassette.

To adjust the length of the paper cassette, align the lock release lever with "Ⓜ" to release the lock, slide the paper cassette by holding the rear portion of the paper cassette, and then align the lock release lever with "Ⓛ" to lock the cassette.

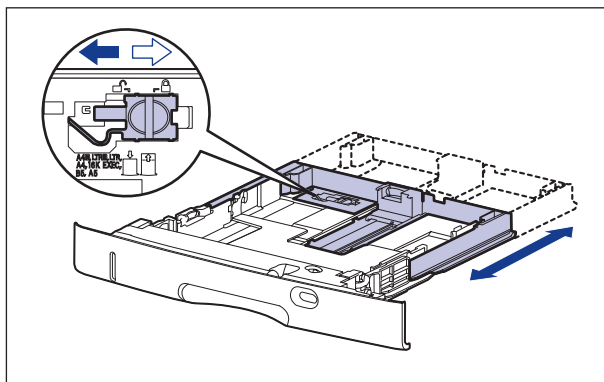

3 Load the paper so that the edge of the paper is aligned with the front side of the paper cassette.

Cassette 1

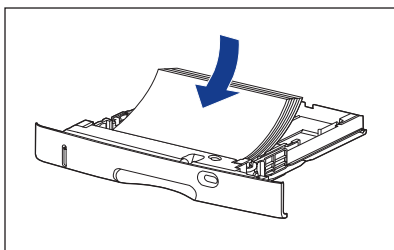

Cassette 2, 3, and 4

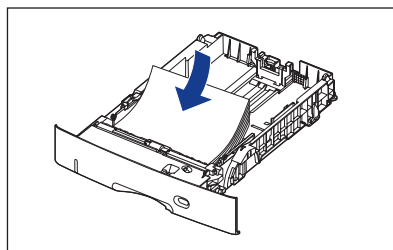

CAUTION

When loading paper, take care not to cut your hands with the edges of the paper.

IMPORTANT

- If you use paper that has been poorly cut, multiple sheets of paper may be fed at once. In this case, fan the paper thoroughly, and then align the edges of the stack on a hard, flat surface.
- When custom size paper is printed from LIPS LX Printer Driver, you can load the paper either in portrait or landscape orientation. However, when you are printing custom size paper of its long edges 297.0 mm or less with <カセット N (N=1、2、3、4) ヨウシサイズ> set to <フリー>, load the paper in landscape orientation. When you are not printing from LIPS LX Printer Driver, load the paper in portrait orientation.

NOTE

To print letterhead paper or paper printed with a logo, load the paper in the proper orientation according to the following instructions:

(: Feeding direction)

- When loading paper in landscape orientation, load the paper so that the printing side is facing down as shown in the following figures.

Cassette 1

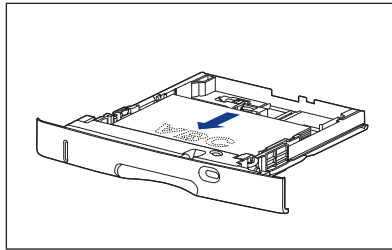
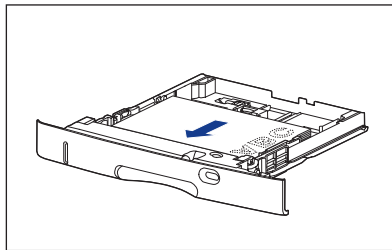

Cassette 2, 3, and 4

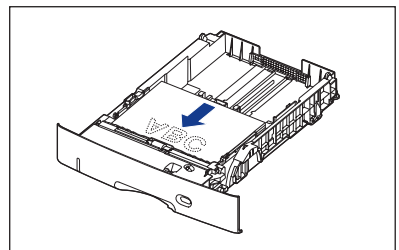
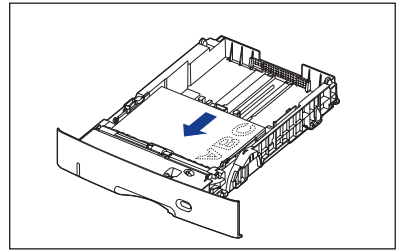

- When loading paper in portrait orientation, load the paper so that the printing side is facing down as shown in the following figures.

Cassette 1

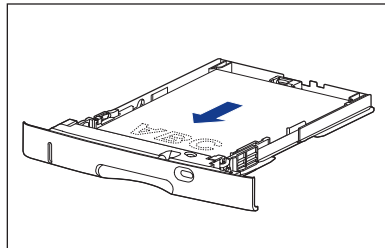
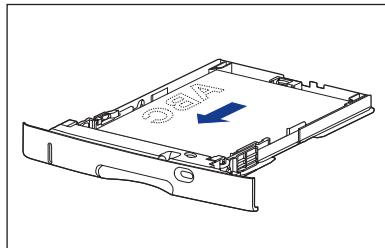

Cassette 2, 3, and 4

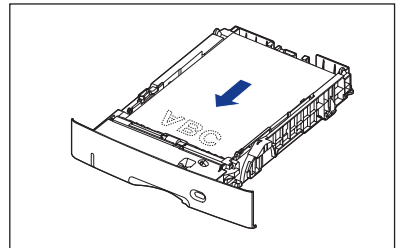
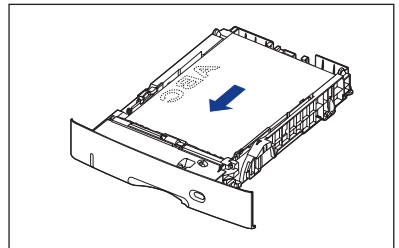

4 While holding the lock release lever of the side paper guides, slide the guides to the size mark for the loaded paper.

The side paper guides move together.

Cassette 1

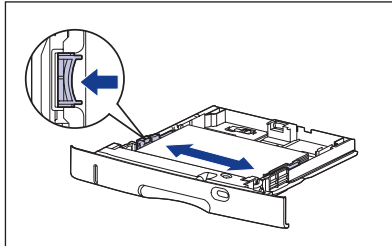

Cassette 2, 3, and 4

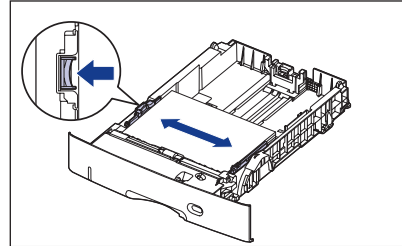

IMPORTANT

Be sure to align the paper guides with the width of the paper. If the paper guides are too loose or too tight, this may result in misfeeds or paper jams.

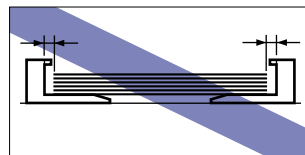
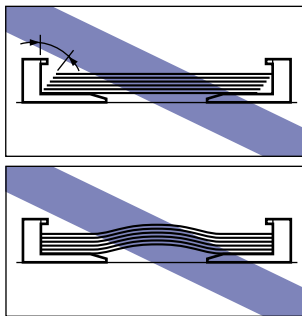

5 While holding the lock release lever of the rear paper guide, slide the guide to the size mark for the loaded paper.

Cassette 1

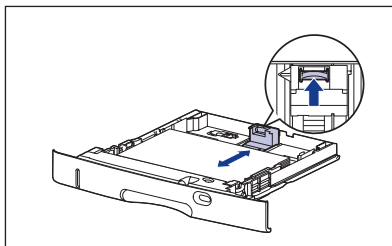

Cassette 2, 3, and 4

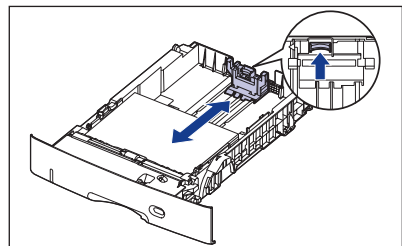

6 Hold down the paper as shown in the figure, make sure that the paper stack does not exceed the load limit marks (A), and then set it under the hooks (B) on the paper guides.

Make sure that there is sufficient space between the hooks of the paper guides and the paper stack. If there is no sufficient space, slightly reduce the amount of paper.

Cassette 1

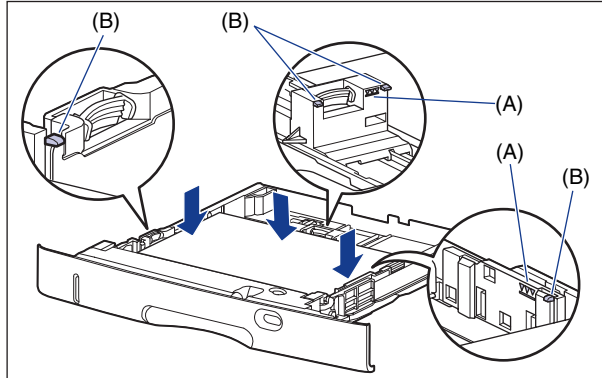

Cassette 2, 3, and 4

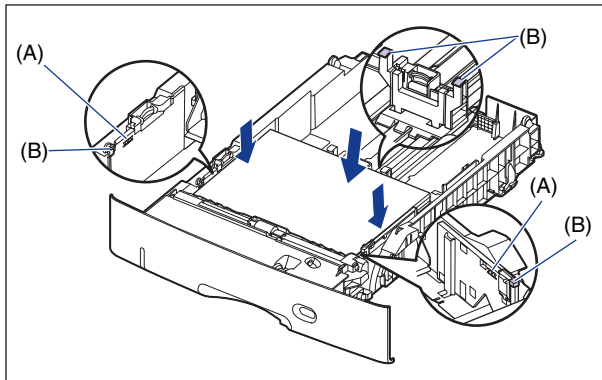

IMPORTANT

The paper capacity of Cassette 1 is approximately 250 sheets of plain paper (64 g/m²), and that of Cassette 2, 3, and 4 is approximately 500 sheets of plain paper (64 g/m²). Be sure that the paper stack does not exceed the load limit marks on the paper guides. If the paper stack exceeds the load limit marks, this may result in misfeeds.

7 Holding the tab of the paper size setting switch (A), set it to the left.

Cassette 1

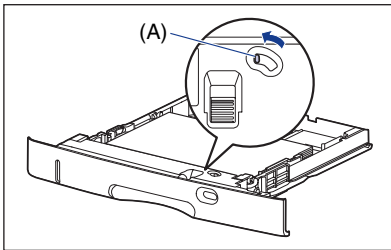

Cassette 2, 3, and 4

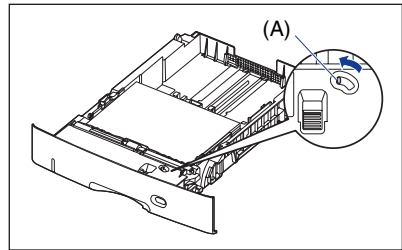

8 Set the paper size register dial (A) to "Custom".

Cassette 1

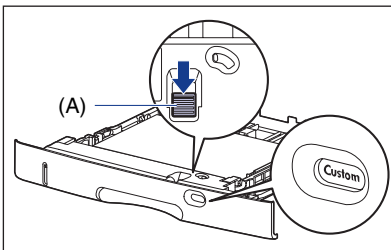

Cassette 2, 3, and 4

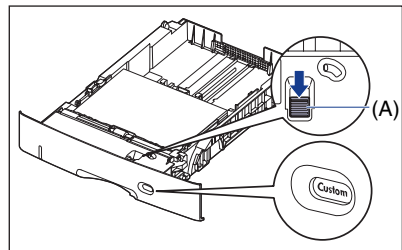

IMPORTANT

Make sure that the paper size register dial is set to "Custom" before setting the paper cassette in the printer. If the paper size that the paper size register dial is indicating does not correspond with the size of the loaded paper, this may result in printer malfunction.

9 Set the paper cassette in the printer at an angle as shown in the figure ①, then push it into the printer or paper feeder gently and horizontally ②.

Push the paper cassette into the printer firmly until the front side of the paper cassette is flush with the front surface of the printer.

Cassette 1

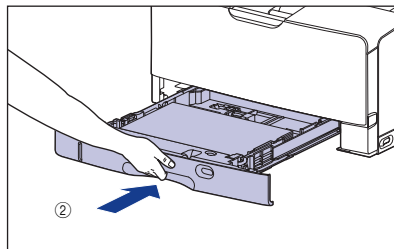
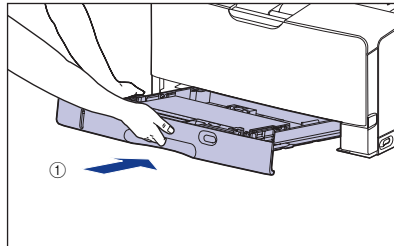

Cassette 2, 3, and 4

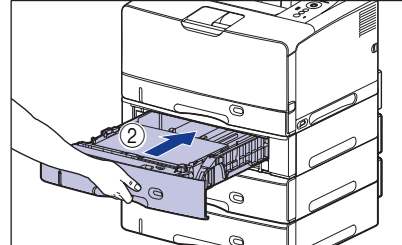
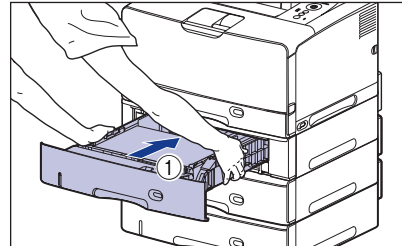

CAUTION

When setting the paper cassette in the printer, be careful not to catch your fingers.

Loading Paper in the Multi-purpose Tray

Load paper in the multi-purpose tray. The paper loading procedure varies depending on the paper type. Refer to the respective procedures for each paper type.

- Plain Paper, Heavy Paper, Transparency, Label (See "When Loading Paper (Other than Postcards and Envelopes)," on p. 36)
- Postcard, Envelope (See "When Loading Postcards or Envelopes," on p. 43)



IMPORTANT

For more details on the usable paper, see "Usable Paper," on p. 7.

When Loading Paper (Other than Postcards and Envelopes)

Perform the following procedure to load plain paper, heavy paper, transparencies, or labels in the multi-purpose tray.

Load paper in portrait or landscape orientation. Depending on the size of the paper to be loaded, the loading orientation differs as follows:

Landscape orientation

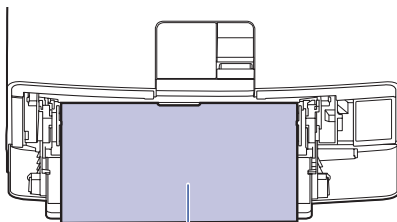

Ex. A4

Paper that can be loaded in landscape orientation:
A4, B5, A5, Letter, Executive

Portrait orientation

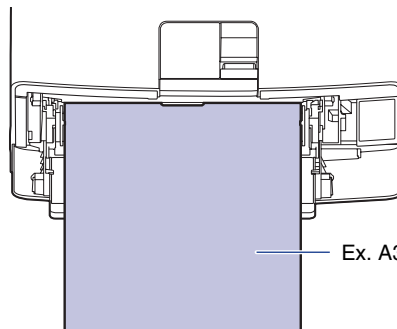

Ex. A3

Paper that can be loaded in portrait orientation:
A3, B4, A4R, Ledger (11 x 17), Legal, LetterR

1 Open the multi-purpose tray.

Holding the silver opening at the center of the printer, open the multi-purpose tray.

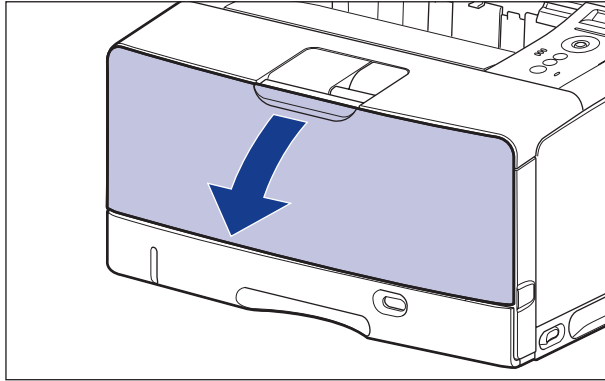

2 Pull out the auxiliary tray.

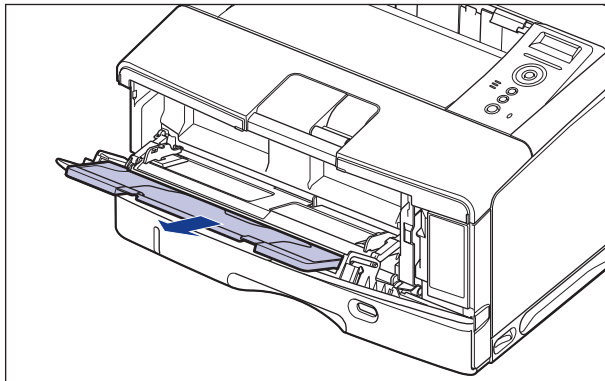

IMPORTANT

Be sure to pull out the auxiliary tray when loading paper in the multi-purpose tray.

- 3** When loading long-size paper such as A3, B4, etc, open the tray extension.

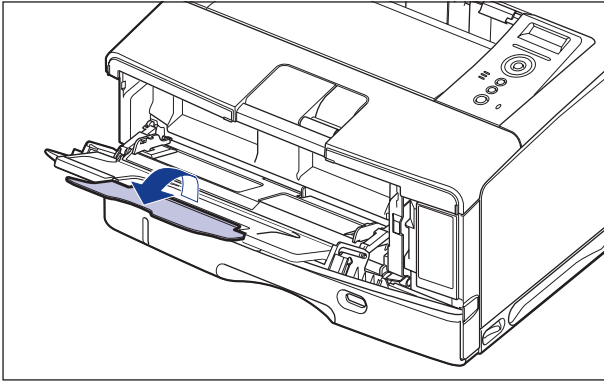

- 4** Spread the paper guides a little wider than the actual paper width.

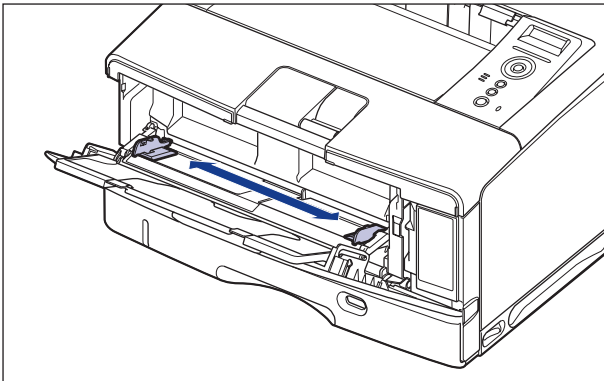

5 Before loading transparencies or labels, fan them in small batches and align the edges.

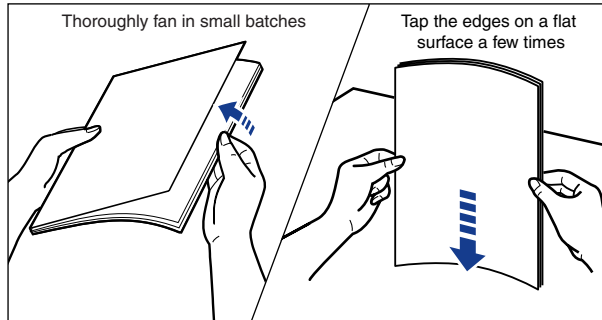

CAUTION

When loading paper, take care not to cut your hands with the edges of the paper.

IMPORTANT

- Be sure to fan the transparencies or labels thoroughly before loading them. If they are not fanned enough, multiple sheets of paper may be fed at once, causing paper jams.
- When fanning or aligning the transparencies, try to hold the edges to avoid touching the printing surface.
- Take care not to mark or stain the printing surface of the transparencies with fingerprints, dust, or oil. This may result in poor print quality.

6 Gently load the stack of paper with the printing side facing up until it touches the back of the tray.

Be sure that the paper stack is loaded under the load limit guides (A).

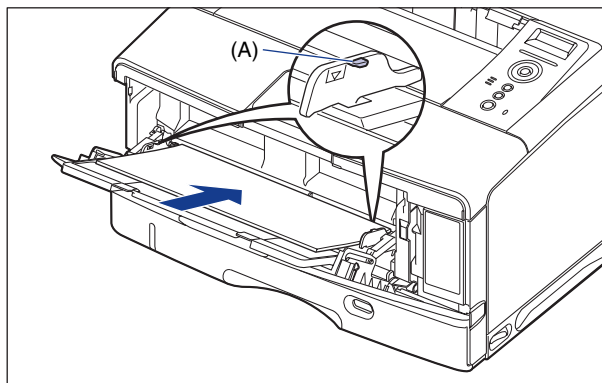



CAUTION

When loading paper, take care not to cut your hands with the edges of the paper.



IMPORTANT

- The multi-purpose tray can be loaded with up to the number of sheets listed below. Make sure that the paper stack does not exceed the load limit guides.
 - Plain paper : Approx. 100 sheets (Ex. 64 g/m²)
 - Heavy paper : Approx. 50 sheets (Ex. 128 g/m²)
 - Transparency : Approx. 50 sheets
 - Label : Approx. 40 sheets
- Load the paper so that it is straight.
- If the rear edge of the paper stack is not properly aligned, this may result in misfeeds or paper jams.
- If the paper is curled or folded at corners, flatten it before loading it in the printer.
- If you use paper that has been poorly cut, multiple sheets of paper may be fed at once. In this case, fan the paper thoroughly, and then align the edges of the stack on a hard, flat surface.
- When custom size paper is printed from LIPS LX Printer Driver, you can load the paper either in portrait or landscape orientation. However, when you are printing custom size paper of its long edges 312.0 mm or less with <テザシトレイ ヨウシサイズ> set to <フリー>, load the paper in landscape orientation. When you are not printing from LIPS LX Printer Driver, load the paper in portrait orientation.



NOTE

To print letterhead paper or paper printed with a logo, load the paper in the proper orientation according to the following instructions:

(← : Feeding direction)

- When loading paper at a size of A4, B5, A5, Letter, or Executive in landscape orientation, load the paper so that the printing side is facing up, as shown in the following figures.

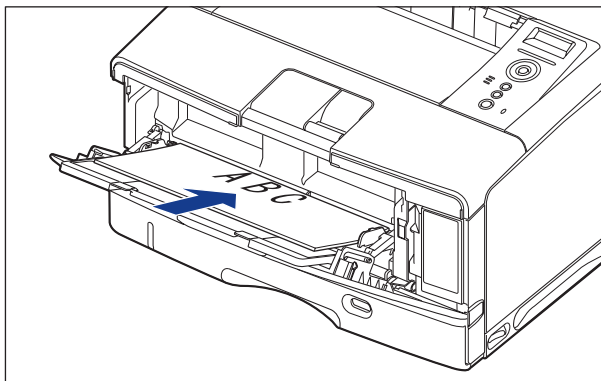
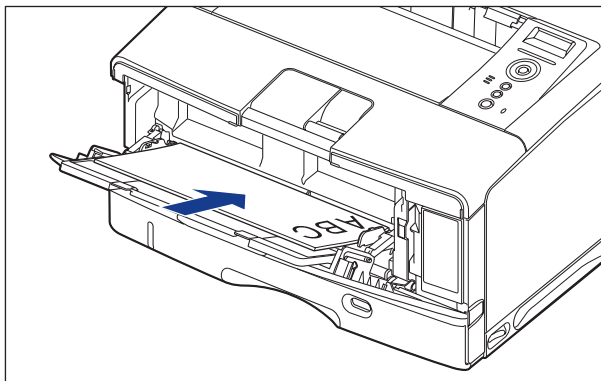

- When loading paper at a size of A3, B4, A4R, Ledger (11 x 17), Legal, or LetterR in portrait orientation, load the paper so that the printing side is facing up, as shown in the following figures.

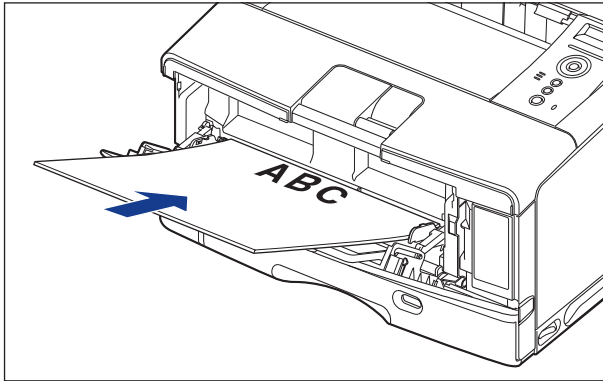
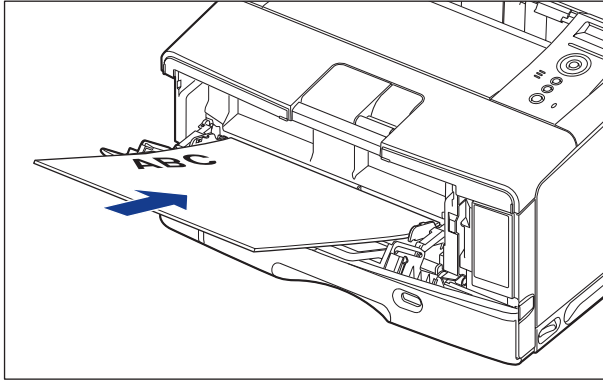

7 Align the paper guides with both sides of the stack.

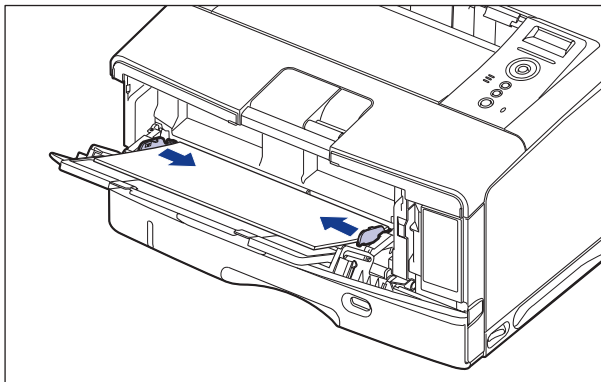

 **IMPORTANT**

Be sure to align the paper guides with the width of the paper. If the paper guides are too loose or too tight, this may result in misfeeds or paper jams.

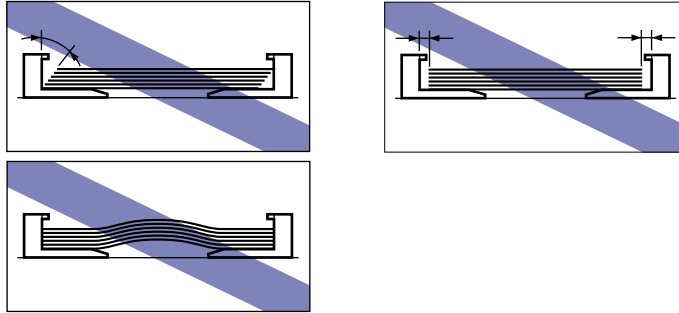

When Loading Postcards or Envelopes

You can load postcards at sizes of Postcard, Reply postcard, 4 on 1 postcard, and 4 on 1 postcard recommended by Canon, and envelopes at sizes of YOUGATA No. 4, YOUGATA No. 2, and KAKUGATA No. 2 in the multi-purpose tray. Use the following procedure when loading postcards or envelopes in the multi-purpose tray.

 **NOTE**

This printer can print plain paper (60 - 90 g/m²) or heavy paper (91 - 199 g/m²) at sizes of Postcard, Reply postcard, and 4 on 1 postcard. When printing plain paper or heavy paper at a size of Postcard, Reply postcard, or 4 on 1 postcard, see "When Loading Paper (Other than Postcards and Envelopes)," on p. 36.

1 Open the multi-purpose tray.

Holding the silver opening at the center of the printer, open the multi-purpose tray.

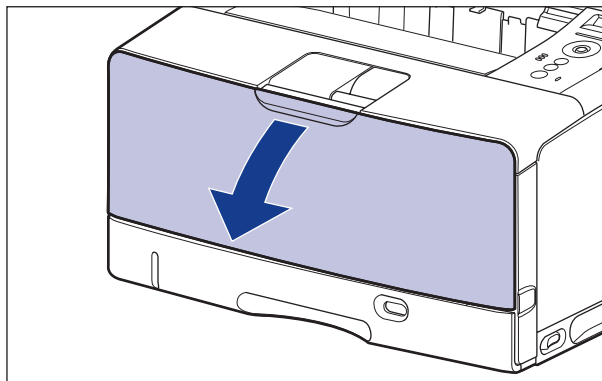

2 Pull out the auxiliary tray.

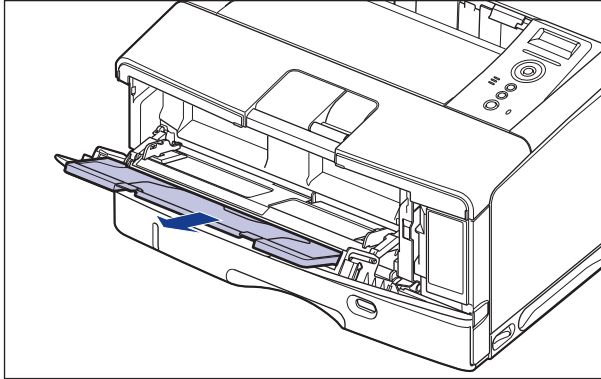

IMPORTANT

Be sure to pull out the auxiliary tray when loading paper in the multi-purpose tray.

3 When loading long-size paper such as envelopes of the KAKUGATA No. 2 size, open the tray extension.

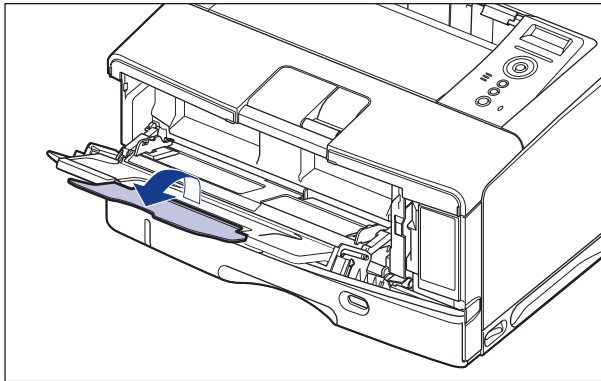

- 4** Spread the paper guides a little wider than the actual paper width.

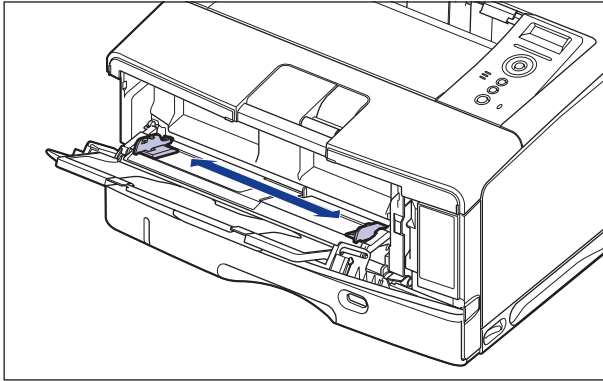

- 5** Before loading envelopes, align them as shown in the following figures.

- Place the stack of envelopes on a flat surface, flatten them to release any remaining air, and be sure that the edges are pressed tightly.

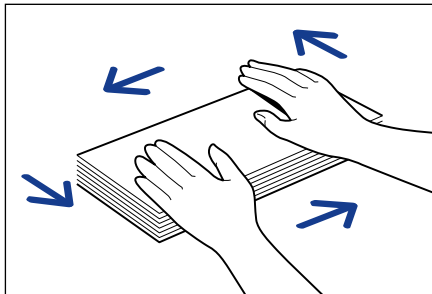

CAUTION

When loading paper, take care not to cut your hands with the edges of the paper.

- Loosen any stiff corners of the envelopes and flatten curls as shown in the figure.

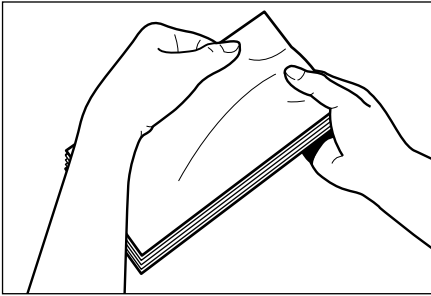

- Align the edges of the envelopes on a flat surface.

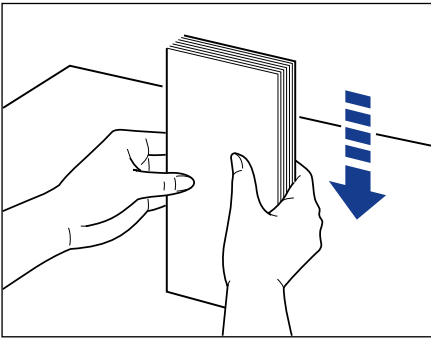

6 Gently load the stack of paper with the printing side facing up until it touches the back of the multi-purpose tray as shown in the figure.

Be sure that the paper stack is loaded under the load limit guides (A).

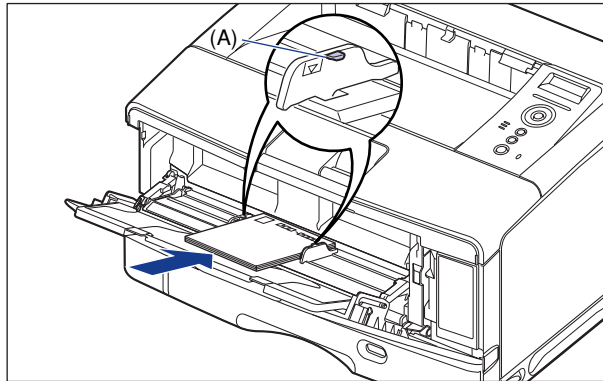

CAUTION

When loading paper, take care not to cut your hands with the edges of the paper.



IMPORTANT

- Load postcards or envelopes as shown in the following figures.
(← : Feeding direction)

YOUGATA No. 4/YOUGATA No. 2

Load the envelopes so that the flap is toward the left of the printer when viewed from the front.

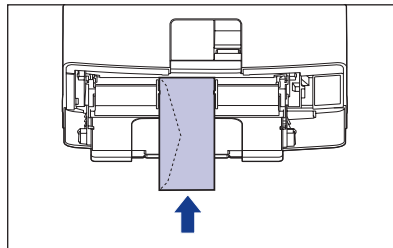

KAKUGATA No. 2

Load the envelopes so that the bottom of the envelopes is toward the back of the printer when viewed from the front.

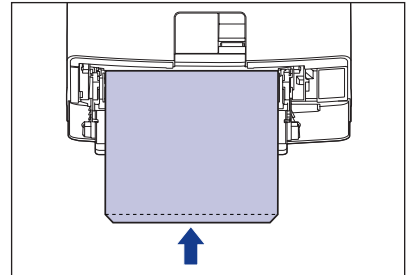

Postcard/Reply Postcard

Load the postcards so that the top of the postcards is toward the back of the printer when viewed from the front.

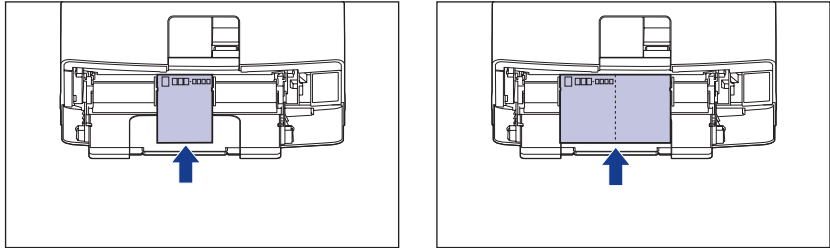

4 on 1 Postcard

Load the postcards so that the top of the postcards is toward the right of the printer when viewed from the front.

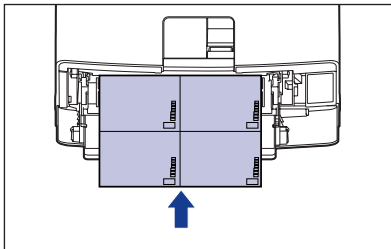

- You can load up to approximately 40 sheets of postcards at sizes of Postcard, Reply postcard, 4 on 1 postcard, and 4 on 1 postcard recommended by Canon, and up to 10 sheets of envelopes. Make sure that the paper stack does not exceed the load limit guides.
- You cannot print on the reverse side (glued side) of envelopes.
- When printing reply postcards, match the paper settings and printing orientation specified in the application with the actual printing orientation. (Example: For Windows 2000/XP/Server 2003, select [Double Japan Postcard Rotated].)
- If the post cards are curled, flatten the curls by warping them in the opposite direction before loading them.
- If you use postcards that have been poorly cut, multiple sheets of postcards may be fed at once. In this case, align the edges of the stack on a hard, flat surface.

7 Align the paper guides with both sides of the stack.

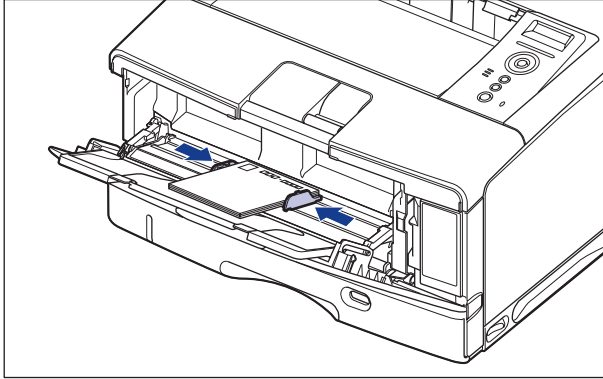

IMPORTANT

Be sure to align the paper guides with the width of the paper. If the paper guides are too loose or too tight, this may result in misfeeds or paper jams.

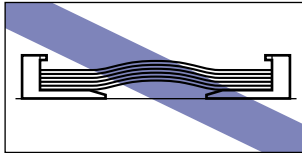
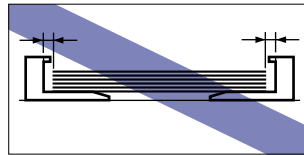
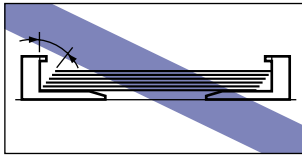

Paper Jams

When a paper jam occurs during printing for some reason, the printer beeps, displaying the message <13 ヨウシガ ツマリマシタ> in the display. When a paper jam occurs, remove the jammed paper using the following procedure, and then resume the job. If the message that indicates the paper jam does not disappear even after removing the jammed paper following the procedure, there is a possibility that torn pieces of paper are still left inside the printer. Inspect each part of the printer again, and completely remove all pieces of jammed paper.

WARNING

There are some areas inside the printer which are subject to high-voltages. When removing jammed paper or when inspecting the inside of the printer, do not allow necklaces, bracelets, or other metal objects to touch the inside of the printer, as this may result in burns or electrical shock.

CAUTION

- **The fixing unit and its surroundings inside the printer are hot during use. Make sure the fixing unit is completely cool before removing the jammed paper. Touching the fixing unit when it is still hot may result in burns.**
- **When removing jammed paper, take care not to allow the toner to come into contact with your hands or clothing, as this will dirty your hands or clothing. If they become dirty, wash them immediately with cold water. Washing with warm water will set the toner and make it impossible to remove the toner stains.**
- **When removing paper jammed inside the printer, remove the jammed paper gently to prevent the toner on the paper from scattering and getting into your eyes or mouth. If the toner gets into your eyes or mouth, wash them immediately with cold water and immediately consult a physician.**
- **When removing jammed paper, take care not to cut your hands with the edges of the paper.**
- **Keep your hands or clothing away from the roller in the output area after removing jammed paper completely. Even if the printer is not printing, sudden rotation of the roller may catch your hands or clothing, resulting in personal injury.**

IMPORTANT

- **Remove jammed paper while the power of the printer is ON. If the power is turned OFF, the data being printed will be deleted.**
- **Applying excess force may result in tearing paper or damaging the parts in the printer. When removing jammed paper, pull out the paper in the most appropriate direction, judging from the position of the paper.**

- If paper is torn, be sure to find and remove any remaining pieces of paper.
- The error message may remain if jammed paper is removed without opening the front cover. In this case, open and close the front cover once.
- Do not touch the high-voltage contact (A) or the electrical contact (B) shown in the figure, as this may result in damage to the printer.

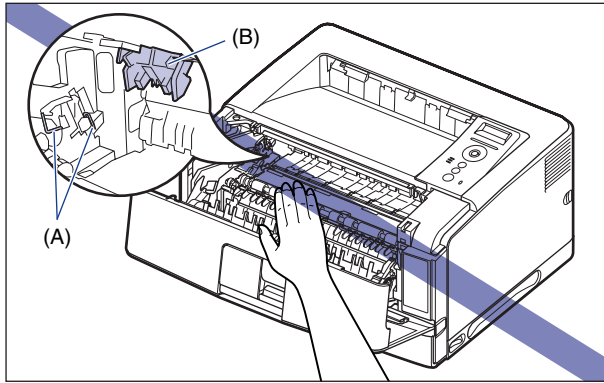

- Do not touch the transfer roller (C), as this may result in deterioration in print quality.

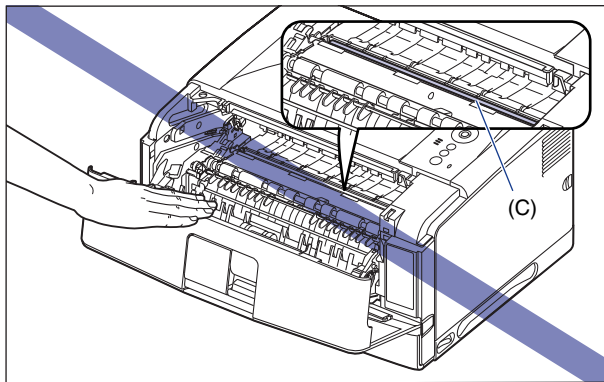

- The surroundings of the output tray and sub-output tray are hot during printing or immediately after printing. When taking out of the paper or removing jammed paper, be careful not to touch the surroundings of the output tray or sub-output tray.

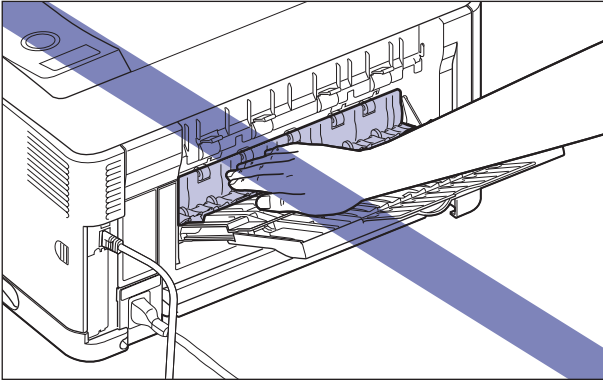
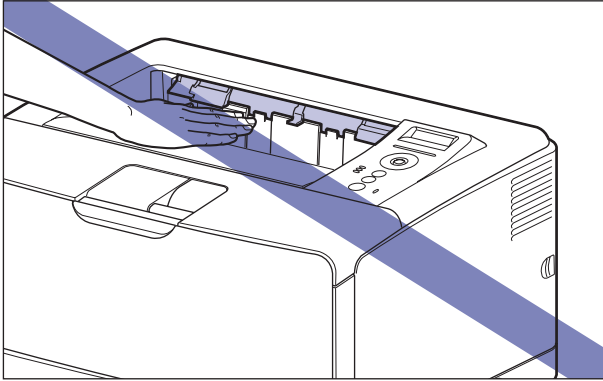

Paper Jam Area

The messages displayed in the Printer Status Window indicate where the paper is jammed.

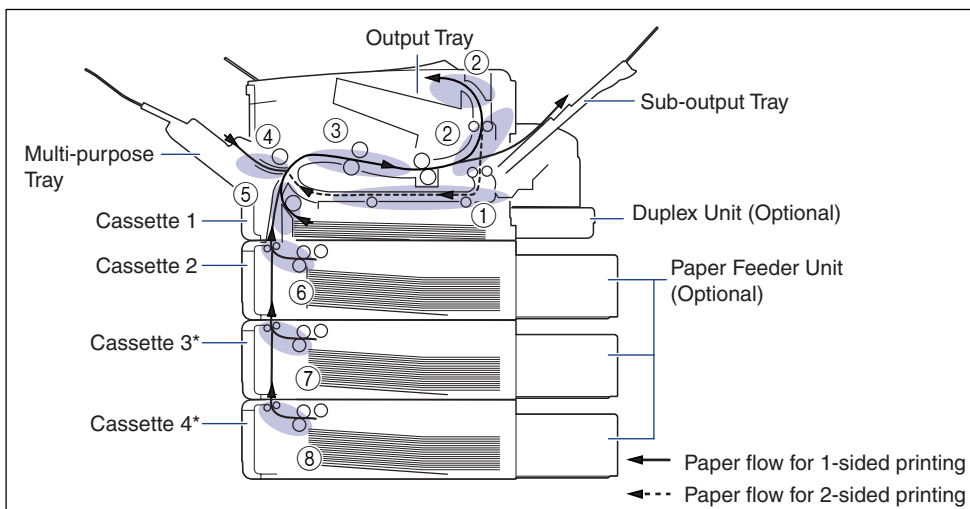

Paper Jam Area		Display Message
①	Duplex print transport area (only when the duplex unit is installed)	リョウメンユニット エリア
②	Output tray, Sub-output tray	サブハイシトレイ エリア
③	Inside the front cover	マエカバー エリア
④	Multi-purpose tray	テザシトレイ エリア
⑤	Cassette 1	カセット 1 エリア
⑥	Cassette 2 (only when the paper feeder is installed)	カセット 2 エリア
⑦	Cassette 3* (only when the paper feeder is installed)	カセット 3 エリア
⑧	Cassette 4* (only when the paper feeder is installed)	カセット 4 エリア

* Cassette 3 and Cassette 4 can be installed only in LBP3970.

Procedure for Clearing Paper Jams

Remove any jammed paper using the following procedures.

1 Confirm all the messages that appear in the display.

Messages appear one at a time. Confirm all of them.

As the messages disappear when the cover is open, take a note of them if required.

13 ヨウシカ ッマリマシタ



マエカハ - エリア

2 Remove any paper jammed in the output trays (the output tray and sub-output tray).



IMPORTANT

If the jammed paper cannot be removed easily, do not try to remove it forcefully but proceed to the next step.

● If the output tray is being used

- Remove any paper jammed in the output tray.

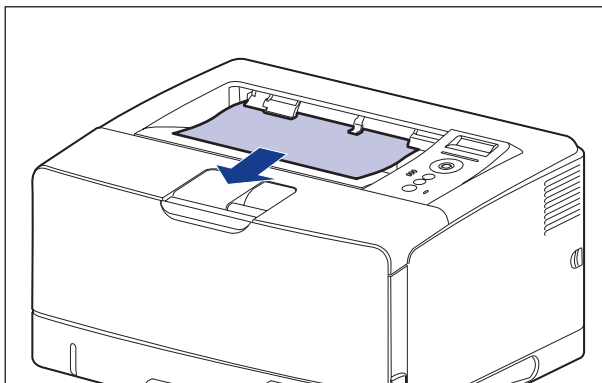

- ❑ Open the sub-output tray.

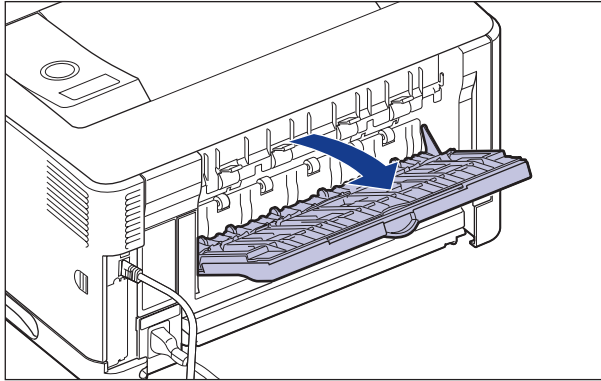

- ❑ Open the white transport guide inside the sub-output tray ①, then remove any jammed paper ②.

Send the top edge of the jammed paper toward you, then remove it.

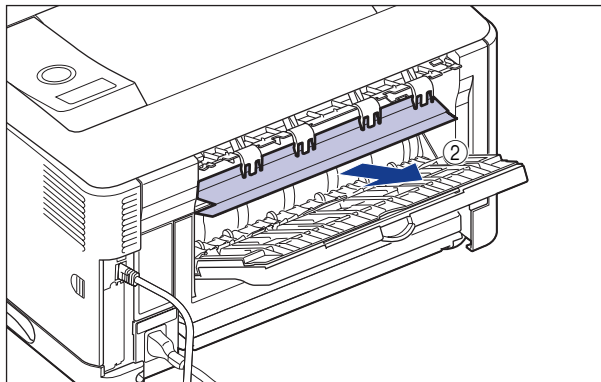
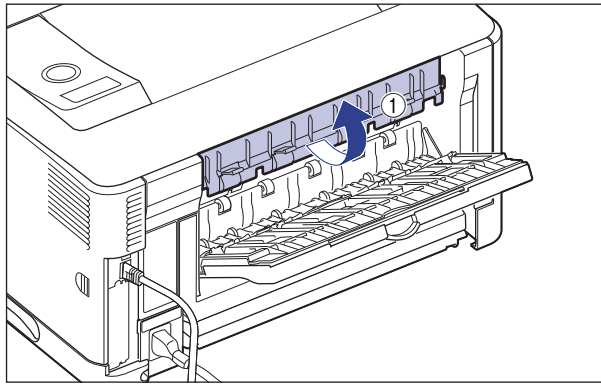

● **If the sub-output tray is being used**

- Remove any paper jammed in the sub-output tray.

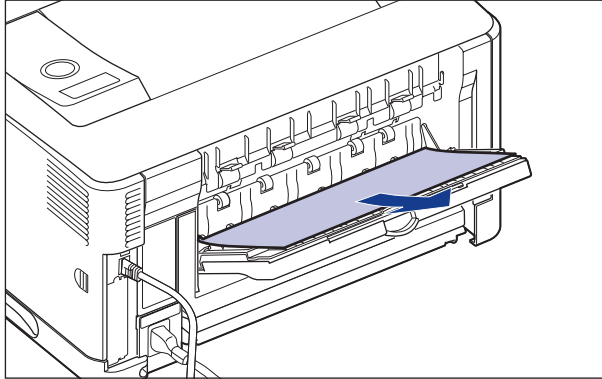

3 If you are using the multi-purpose tray, remove any paper jammed in the multi-purpose tray, and then close it.

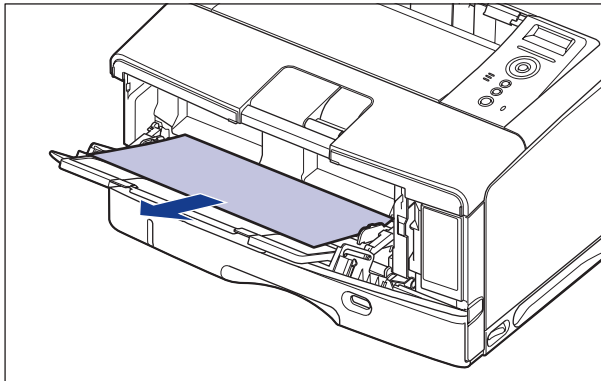

IMPORTANT

If the jammed paper cannot be removed easily, do not try to remove it forcefully but proceed to the next step.

4 Open the front cover.

Open the front cover gently while pressing the lever on the top surface of the cover.

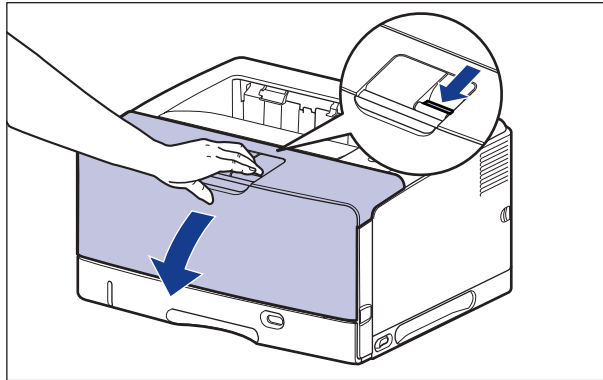

5 Remove the toner cartridge from the printer.

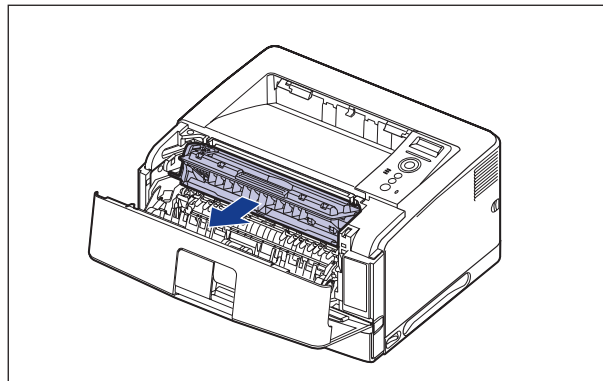



IMPORTANT

Do not touch the high-voltage contact (A) or the electrical contact (B) shown in the figure, as this may result in damage to the printer.

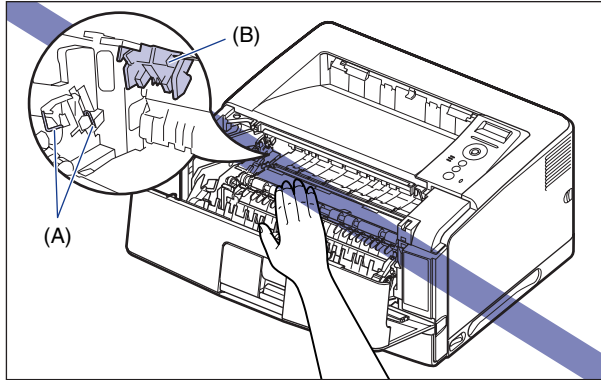

6 Place the toner cartridge into the protective bag.

7 Remove any paper jammed inside the front cover.

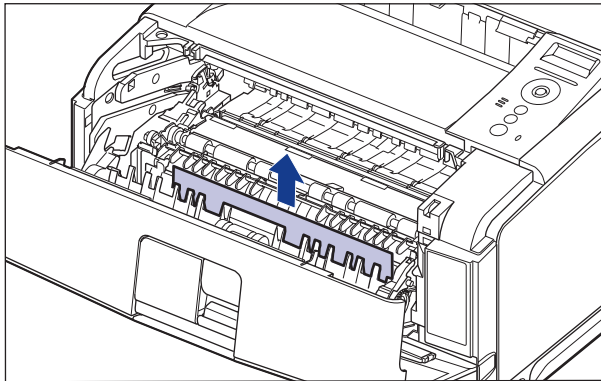

8 Raise the transport guide.

Holding the green tab, raise the transport guide.

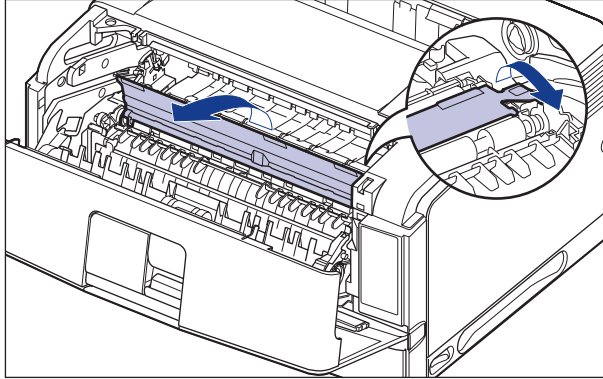

CAUTION

Do not take your hands off the transport guide. The transport guide may snap back to its original position, and this may result in personal injury.

9 Remove any jammed paper.

Send the top edge of the jammed paper out of the transport guide ①, then remove the paper in the direction of the arrow gently ②. Remove the jammed paper in the direction of the arrow gently to prevent unfixed toner from spilling.

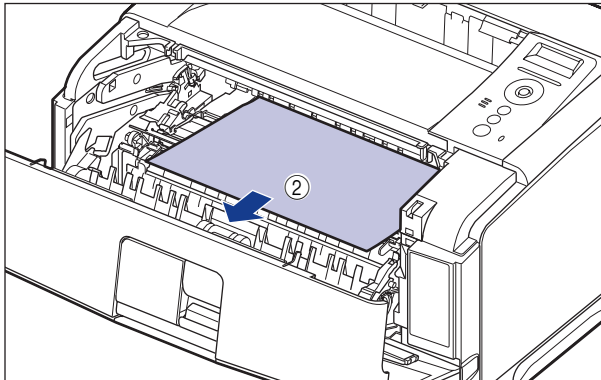
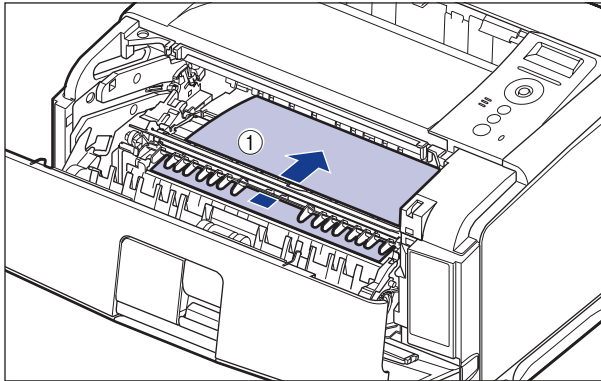

10 If a paper jam occurs when performing 2-sided printing, perform the following procedure.

If you are not performing 2-sided printing, proceed to the next step.

- Raise the black transport guide ①, then remove any jammed paper ②.

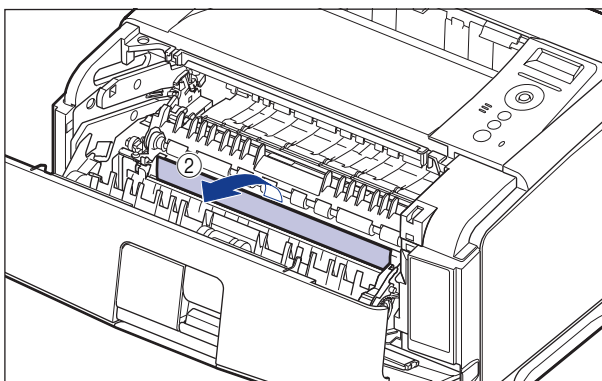
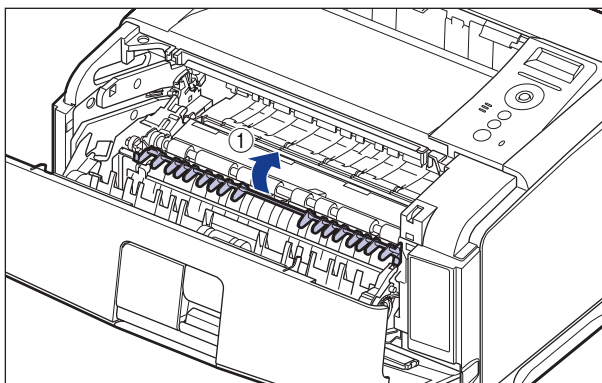

⚠ CAUTION

Do not take your hands off the transport guide. The transport guide may snap back to its original position, and this may result in personal injury.

- ❑ Pull out the duplex unit gently until it stops ①, then raise the front side of the duplex unit and remove it from the printer unit ②.

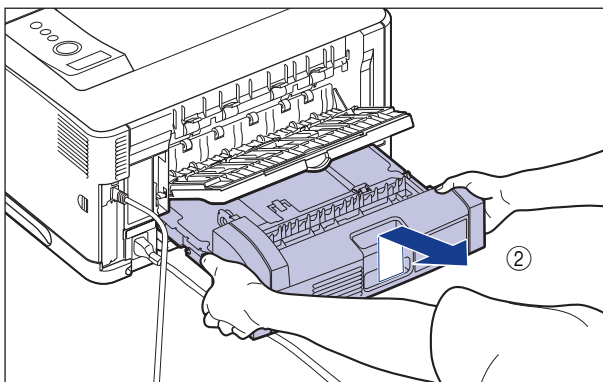
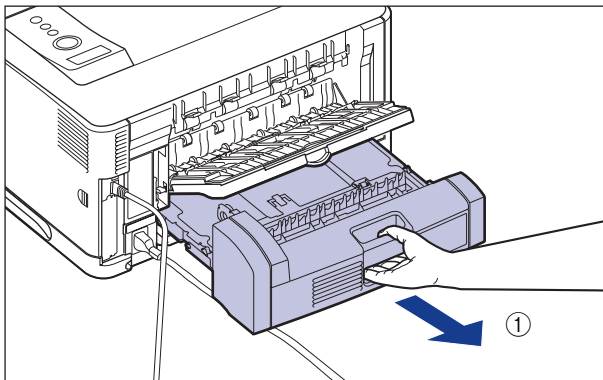

- ❑ Remove any paper jammed in the duplex unit.

If you see the jammed paper in the area of (A), pull out the paper toward you to remove it.

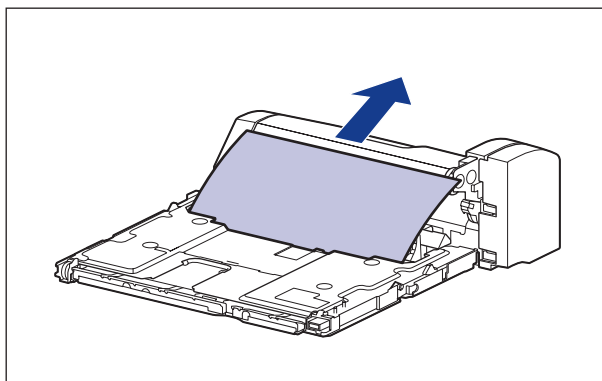
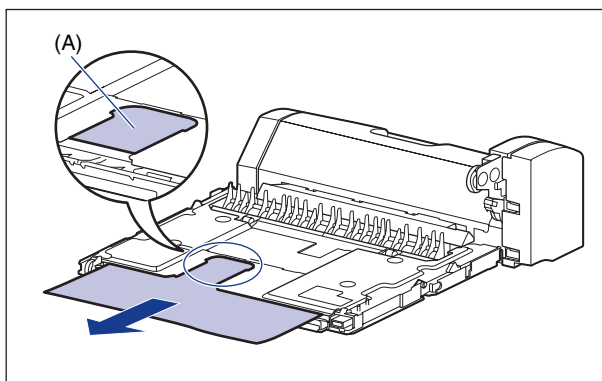

- ❑ Raise the sub-output tray slightly ①, then unhook the hook of the black transport guide ②.

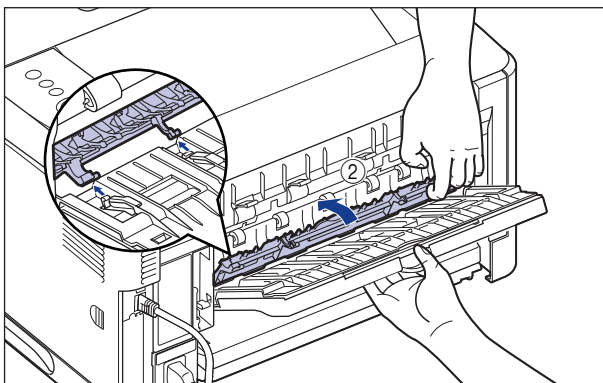
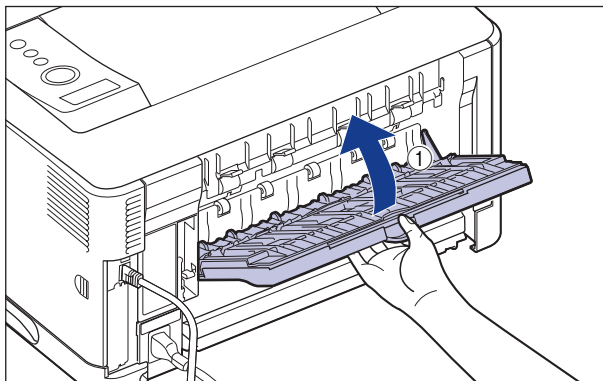

- ❑ Open the sub-output tray to the position shown in the figure.

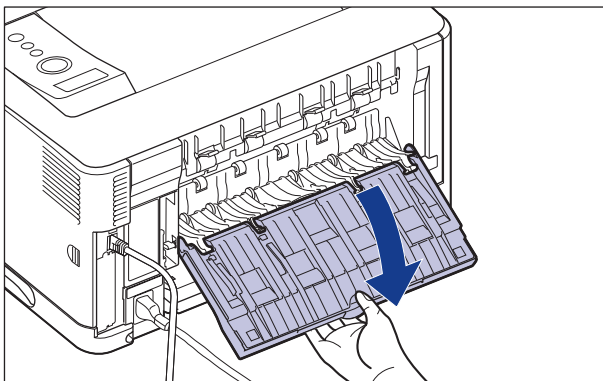

- ❑ Remove any jammed paper.

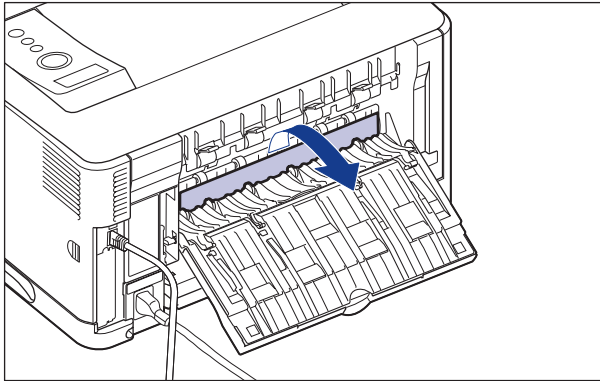

- ❑ Close the sub-output tray.

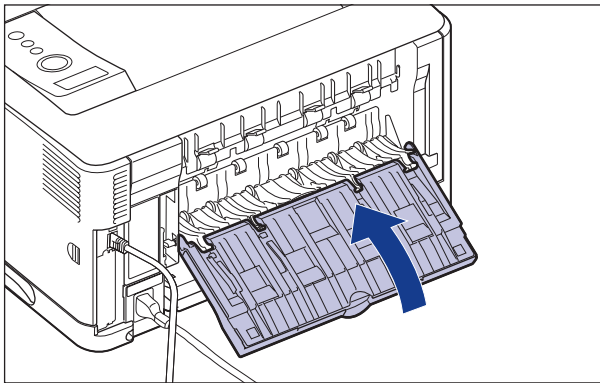

- ❑ Holding the duplex unit as shown in the figure, push it into the printer firmly and horizontally.

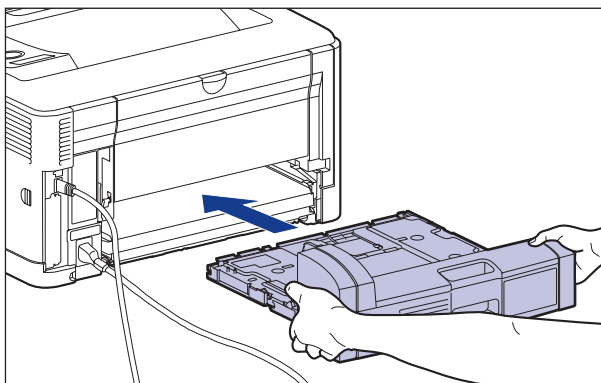

CAUTION

Push the duplex unit gently to avoid catching your hands. Be careful not to hurt your hands.

IMPORTANT

If the duplex unit is not installed on the printer firmly (if there is any space between the rear of the printer and the duplex unit), this may result in misfeeds.

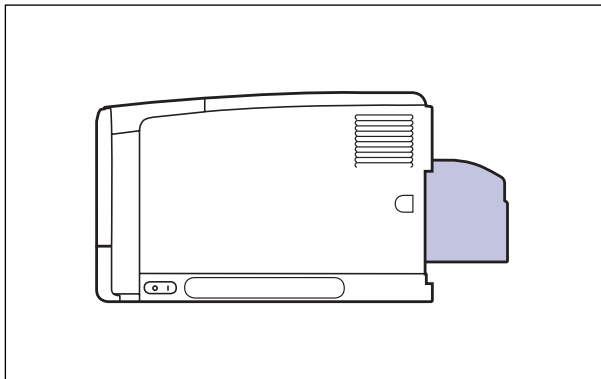
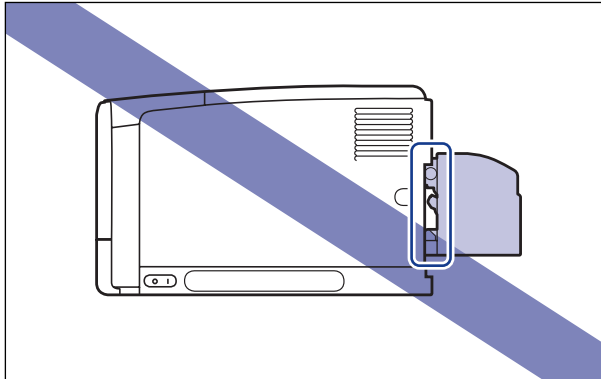

11 If the sub-output tray is being used, open it, and if the output tray is being used, close the sub-output tray.

12 Close the front cover.

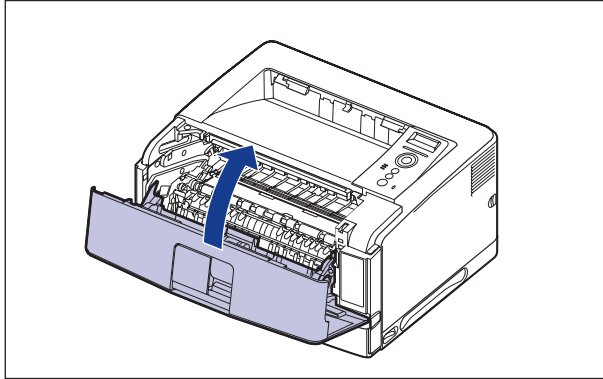

13 If the paper feeders are installed, pull out all the paper cassettes from the bottom.

Pull out the paper cassette until it stops ①.

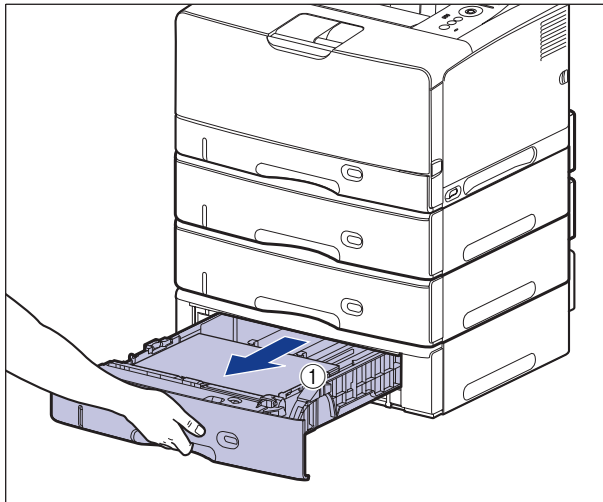

Hold the grips (A) with both hands, raise the front side of the paper cassette slightly ②, and then pull it out completely ③ as shown in the figure.

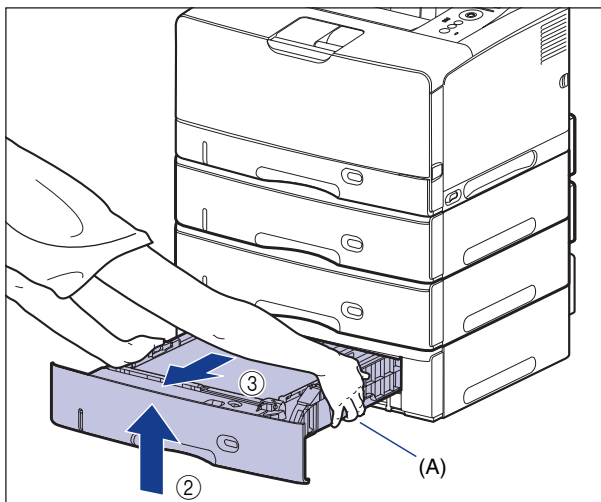

- 14** Pull out the paper cassette of the printer unit gently until it stops ①, then raise the front side of the paper cassette and remove it from the printer unit ②.

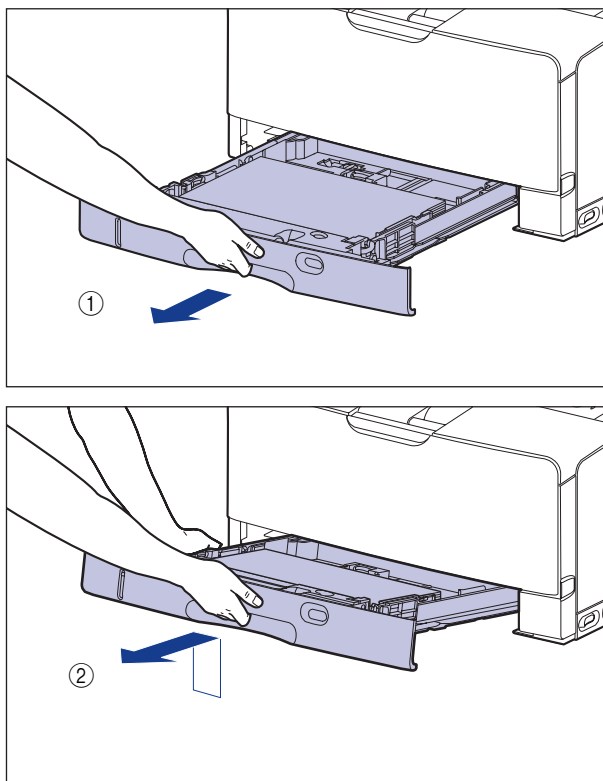

15 Remove any jammed paper.

- If paper is jammed in the paper cassette of the printer unit, pull out the paper downward as shown in the figure.

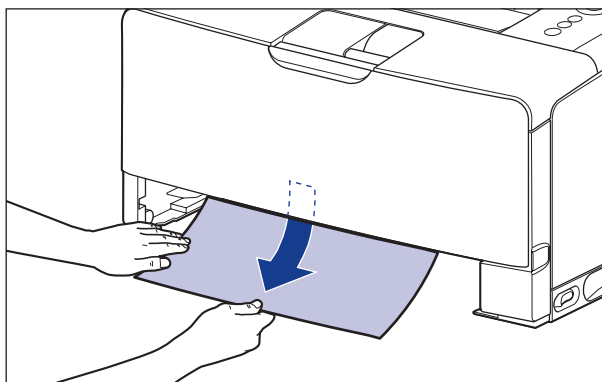

- ❑ If paper is jammed in the paper feeder, pull out the paper upward as shown in the figure.

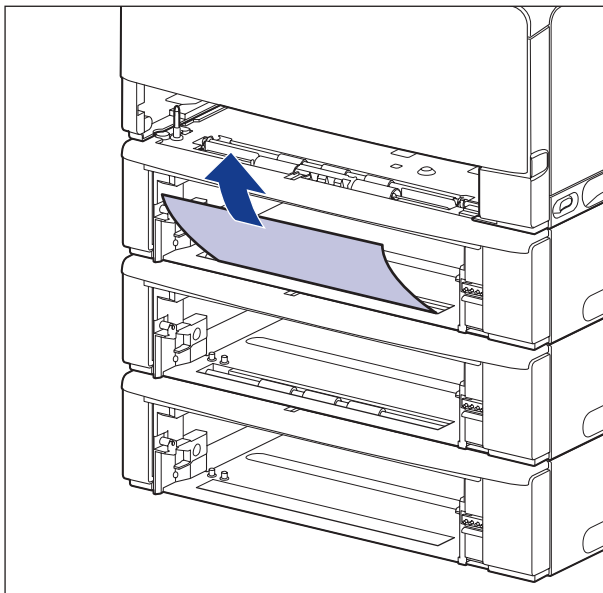

 **IMPORTANT**

Be sure not to touch the feed rollers (A) of the printer and paper feeder. This may result in damage to the printer or printer error.

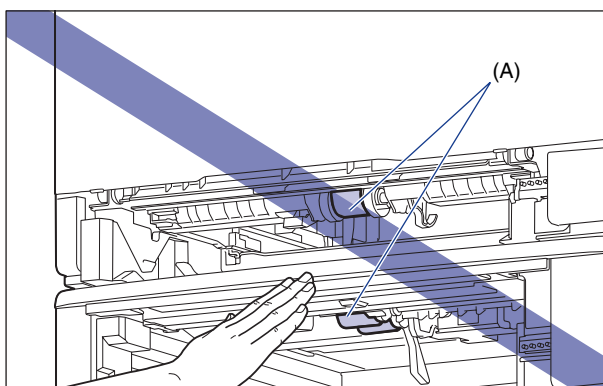

16 Set the paper cassette in the printer at an angle as shown in the figure ①, then push it into the printer gently and horizontally ②.

Push the paper cassette into the printer firmly until the front side of the paper cassette is flush with the front surface of the printer.

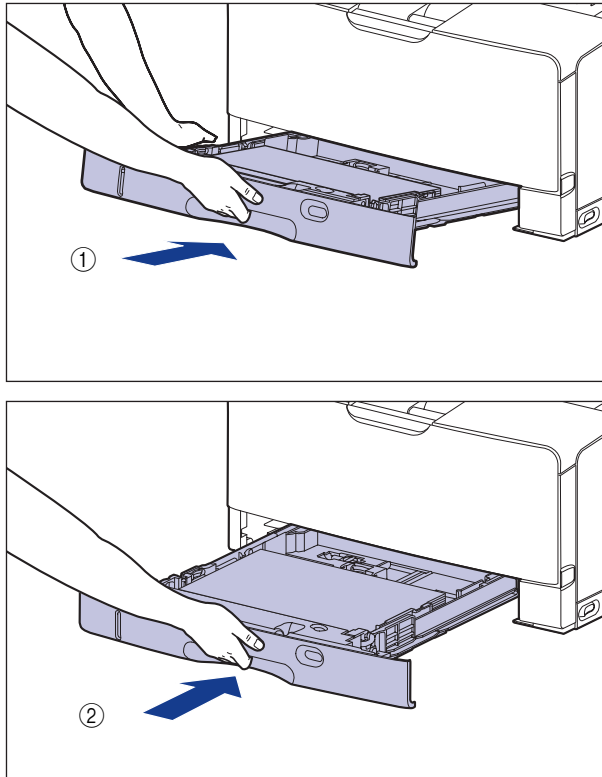

If the paper feeder is installed, set the paper cassette of the paper feeder also.

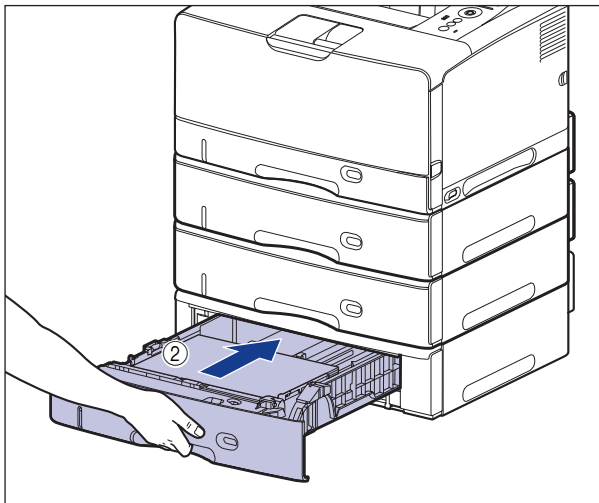
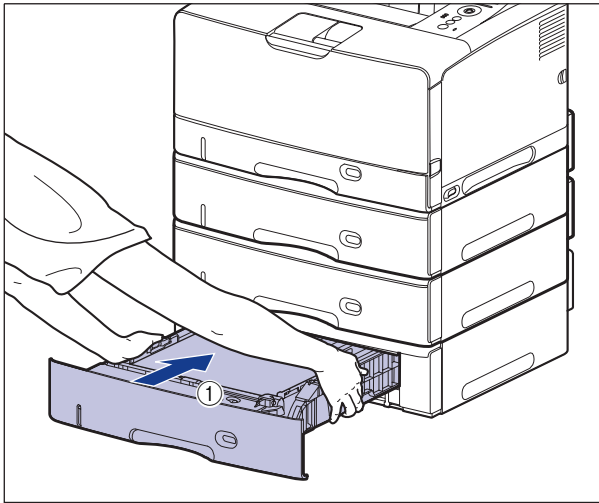

CAUTION

When setting the paper cassette in the printer, be careful not to catch your fingers.

17 Open the front cover.

Open the front cover gently while pressing the lever on the top surface of the cover.

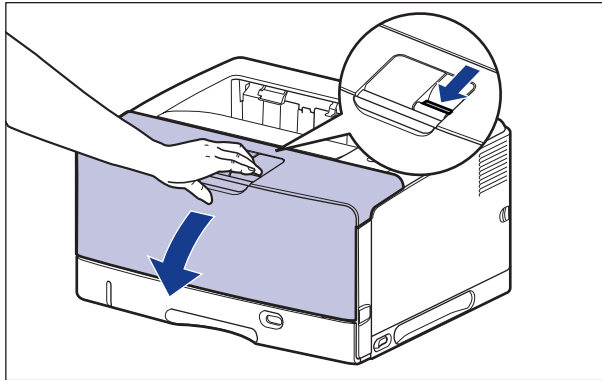

18 Hold the toner cartridge with both hands and install it into the printer.

Align (A) of the toner cartridge with the toner cartridge guides (B), then insert the cartridge until it stops.

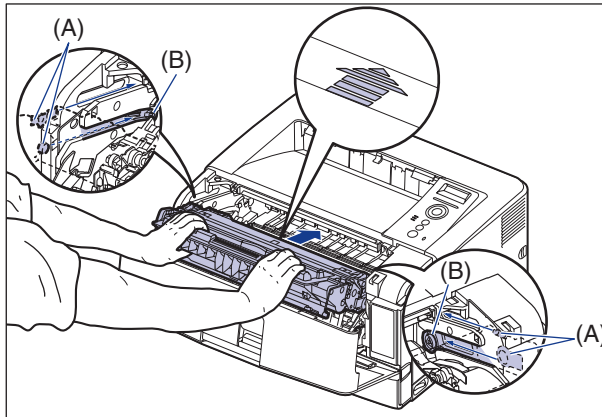

19 Close the front cover.

Close the front cover completely.

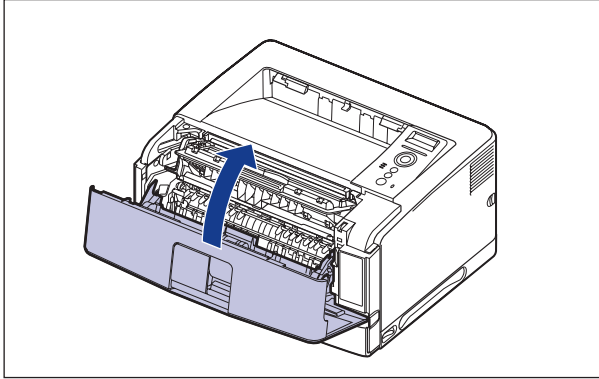

IMPORTANT

- Make sure that the front cover does not open (make sure that there is no space between the front cover and the printer and that the front cover is stable). If the front cover is not closed completely, this may result in poor print quality.
- If you cannot close the front cover, check if the toner cartridge is installed properly. If you try to close the front cover forcefully, this may result in damage to the printer.
- Do not leave the front cover open for a long time after installing the toner cartridge.

Replacing the Toner Cartridge

This section describes how to replace the toner cartridge.

When < トナー ヨウイ/カクニン > Appears

Toner cartridges are consumable products. If the toner is running out during printing, a message appears in the display.

Message	When it is Displayed	Contents and Remedies
16 トナー ヨウイ	When the toner cartridge needs to be replaced soon	<ul style="list-style-type: none">- You can continue to print.- Have a new toner cartridge available.- It is recommended that you replace the toner cartridge before printing a large amount of data.
16 トナー カクニン	When the toner cartridge needs to be replaced soon	<ul style="list-style-type: none">- The printer stops printing.- You can continue to print by pressing [オンライン].- Have a new toner cartridge available.- It is recommended that you replace the toner cartridge before printing a large amount of data.
9F トナー カクニン	When there is a possibility that the toner cartridge has reached the end of its life	<ul style="list-style-type: none">- You can continue to print.- You can continue printing for a while, however, as this may result in damage to the printer, it is recommended to replace the toner cartridge with a new one.
1G トナー カクニン	When the toner cartridge has reached the end of its life	<ul style="list-style-type: none">- You can continue to print.- Replace the toner cartridge with a new one.

* Whether <16 トナー ヨウイ> or <16 トナー カクニン> appears when lifetime of the toner cartridge has reached depends on the setting for <ケイコク ショリ> in the セットアップ menu. The printer is set to display <16 トナー ヨウイ> in the default settings.

 **IMPORTANT**

If the printing appears faint or inconsistent even when the message <16 トナー ヨウイ> or <16 トナー カクニン> does not appear, this may be due to the toner cartridge reaching the end of its life. Do not continue to use the toner cartridge, and replace it with a new one when there is deterioration in print quality. When you are replacing the toner cartridge, be sure to use a toner cartridge designed for this printer.

Model Name	Supported Canon Genuine Toner Cartridge
LBP3970/3920	Cartridge 509

 **NOTE**

The lifetime of the toner cartridges (Canon Genuine Cartridges) designed for this printer is as follows. The page counts are on the basis of "ISO/IEC 19752"* when printing A4 size paper with the default print density setting. The level of toner consumption varies depending on the type of documents printed. If your average document contains a lot of graphics, tables, or charts, the life of the toner cartridge will be shorter as they consume more toner.

- The toner cartridge included with the printer
Approx. 6,000 pages
- The replacement toner cartridge
Cartridge 509: Approximately 12,000 pages

* "ISO/IEC 19752" is the global standard related to "Method for the determination of toner cartridge yield for monochromatic electrophotographic printers and multi-function devices that may contain printer components" issued by ISO (International Organization for Standardization).

Replacing the Toner Cartridge

Replace the toner cartridge with a new one using the following procedure.

 **WARNING**

Do not throw a used toner cartridge into open flames, as this may cause the toner remaining inside the cartridge to ignite, resulting in burns or a fire.

 **CAUTION**

Take care not to allow the toner to come into contact with your hands or clothing, as this will dirty your hands or clothing. If they become dirty, wash them immediately with cold water. Washing with warm water will set the toner and make it impossible to remove the toner stains.

 **IMPORTANT**

Be sure to use only the toner cartridges designed for this printer.

 **NOTE**

The packing materials may be changed in form or position to be placed, or may be added or removed without notice.

1 Open the front cover.

Open the front cover gently while pressing the lever on the top surface of the cover.

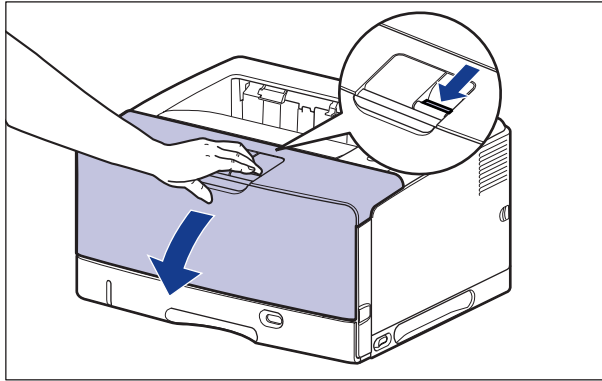

2 Remove the toner cartridge from the printer.

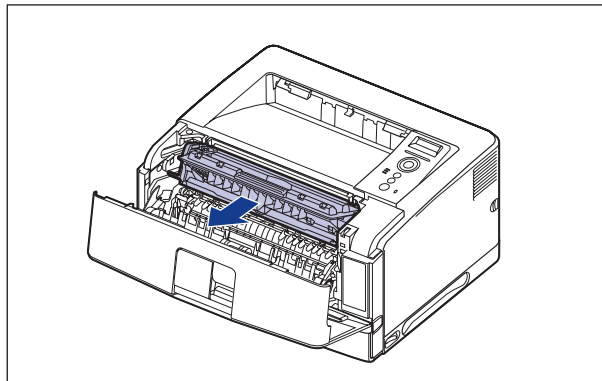

IMPORTANT

Do not touch the high-voltage contact (A) or the electrical contact (B) shown in the figure, as this may result in damage to the printer.

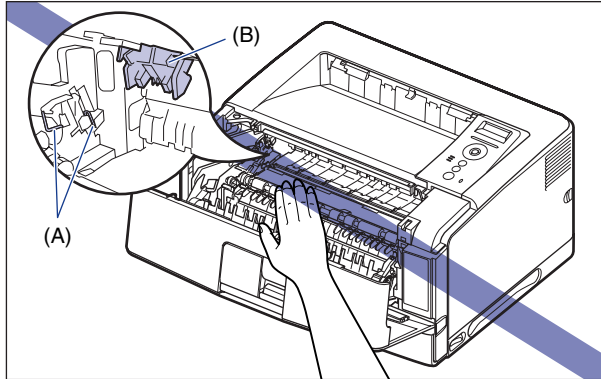

3 Clean the transport guide.

● **Raise the transport guide.**

Holding the green tab, raise the transport guide.

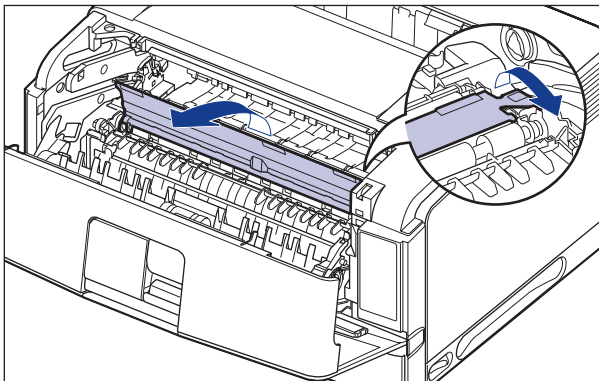

CAUTION

Do not take your hands off the transport guide. The transport guide may snap back to its original position, and this may result in personal injury.

- Using a slightly dampened cloth with water, wipe off chipped paper and toner that are attached to the transport guide.

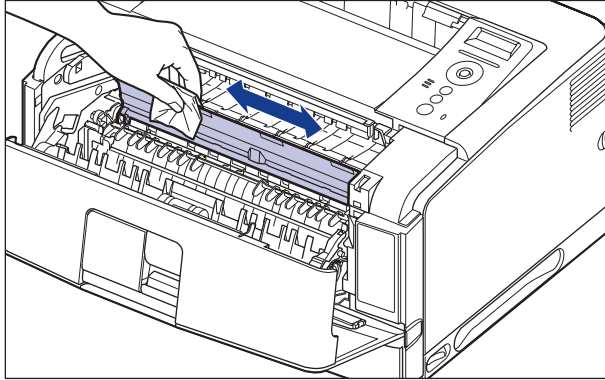

After wiping off the dirt, wipe the area with a soft, dry cloth.

 **IMPORTANT**

- Do not use a cleaning agent such as mild detergent.
- Do not touch the feed roller (A). This may result in damage to the printer or printer error.

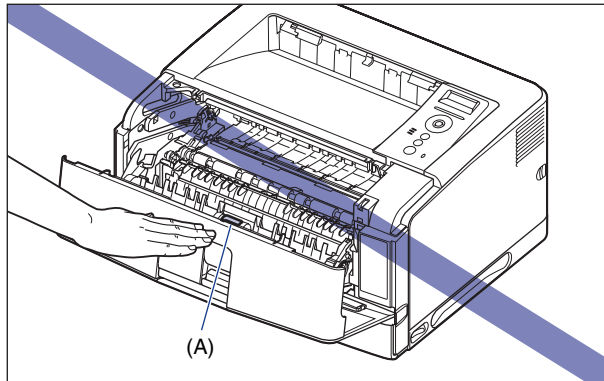

- Be sure that no water or chipped paper is remaining on the transport guide.
- Be sure to finish with wiping with a dry cloth. Water remaining inside the printer may result in damage to the printer.

- Move the transport guide back to its original position slowly.

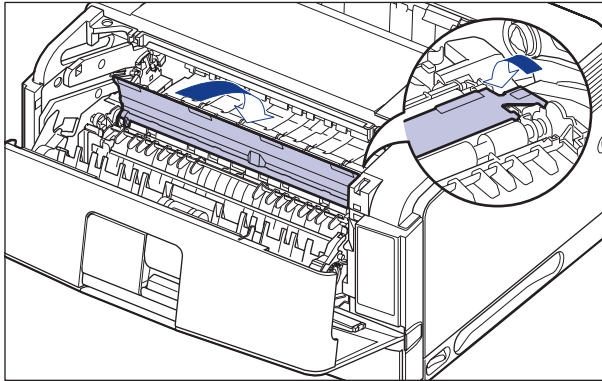

⚠ CAUTION

Do not take your hands off the transport guide until it moves back to its original position. The transport guide may snap back to its original position, and this may result in personal injury.

4 Take the toner cartridge out of the protective bag.

There are cuts on both sides of the protective bag, so you can open it by hand.

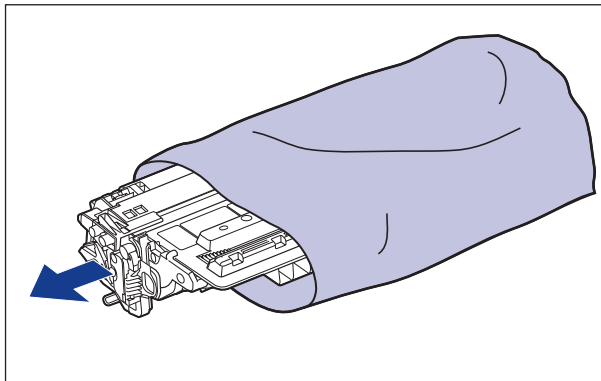

👉 IMPORTANT

Keep the protective bag for the toner cartridge. It may be required after taking out the toner cartridge for printer maintenance.

- 5** Pull up the tape gently while supporting the toner cartridge ①, then remove it together with the black protective sheet ②.

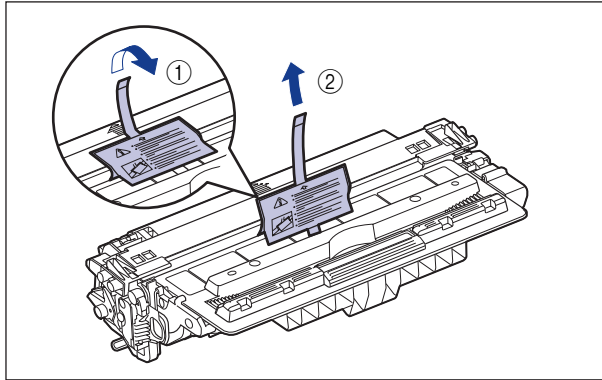

- 6** Hold the toner cartridge as shown in the figure, shake it gently 5 or 6 times to evenly distribute the toner inside the cartridge.

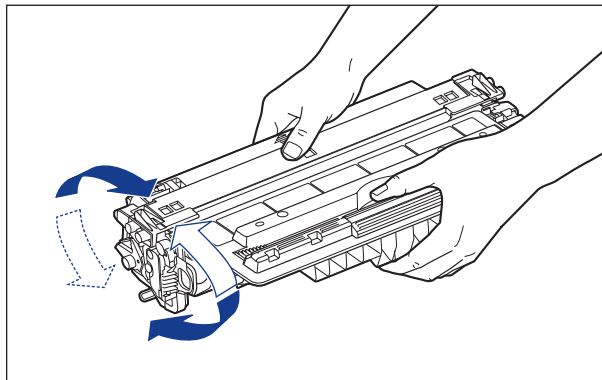

IMPORTANT

- If toner is not distributed evenly, this may result in deterioration in print quality. Be sure to carry out this procedure properly.
- Be sure to shake the toner cartridge gently. If you do not shake the cartridge gently, toner may spill out.

7 Place the toner cartridge on a flat surface, fold back the tab of the sealing tape ①, and then pull out the sealing tape (approx. 72 cm long) gently ② while supporting the toner cartridge.

Remove the sealing tape by hooking your fingers into the tab and pulling it out straight in the direction of the arrow.

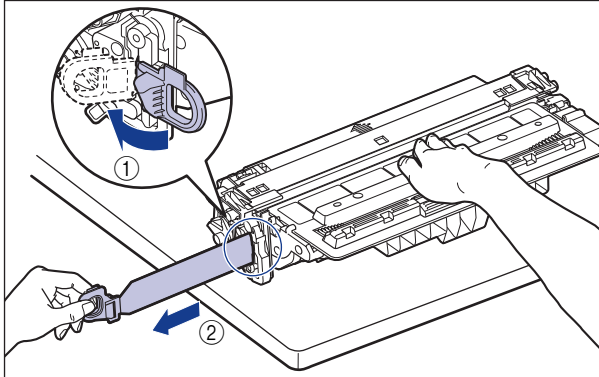

⚠ CAUTION

If the sealing tape is pulled out forcefully or stopped at midpoint, toner may spill out. If the toner gets into your eyes or mouth, wash them immediately with cold water and immediately consult a physician.

👉 IMPORTANT

- Do not pull the sealing tape diagonally, upwards, or downwards. If the tape is severed, it may become difficult to pull out completely.

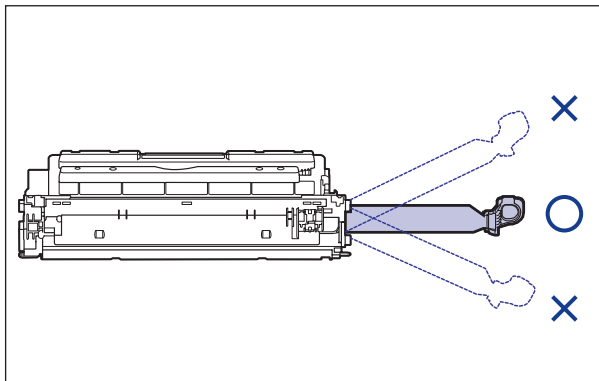

- Pull out the sealing tape completely from the toner cartridge. If any tape remains in the toner cartridge, this may result in poor print quality.

- When pulling out the sealing tape, be careful not to touch the toner cartridge memory (A) or not to hold the drum protective shutter (B) with your hands.

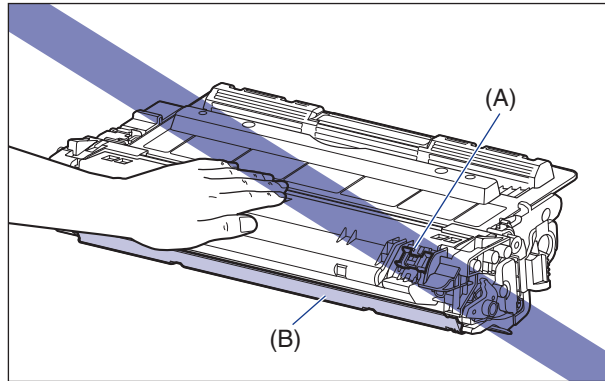

- 8** Hold the toner cartridge properly with the arrowed side facing up as shown in the figure.

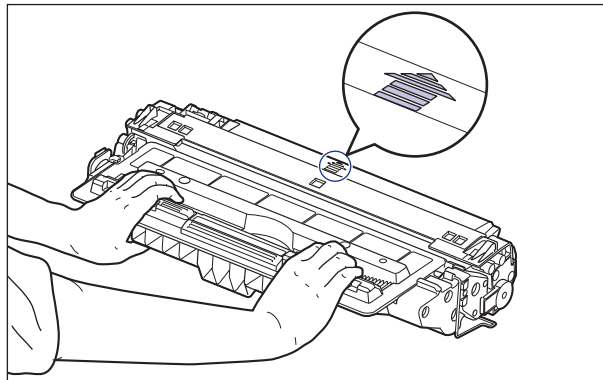



IMPORTANT

Do not hold the toner cartridge in a manner that is not directed in this procedure.

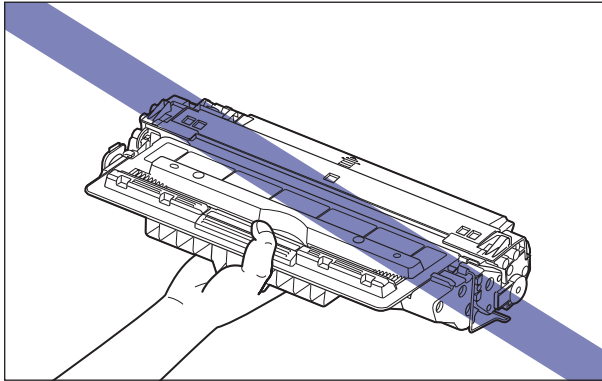

9 Hold the toner cartridge with both hands and install it into the printer.

Align (A) of the toner cartridge with the toner cartridge guides (B), then insert the cartridge until it stops.

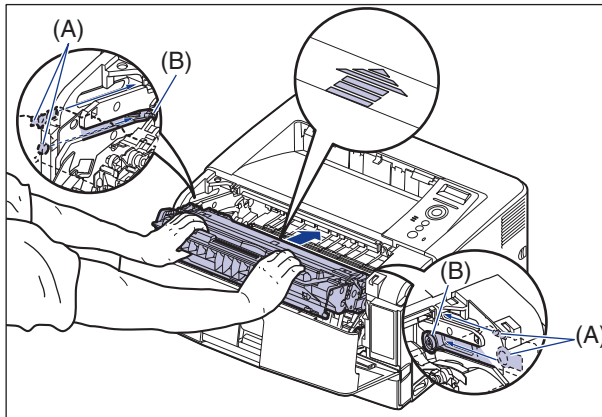

10 Close the front cover.

Close the front cover completely.

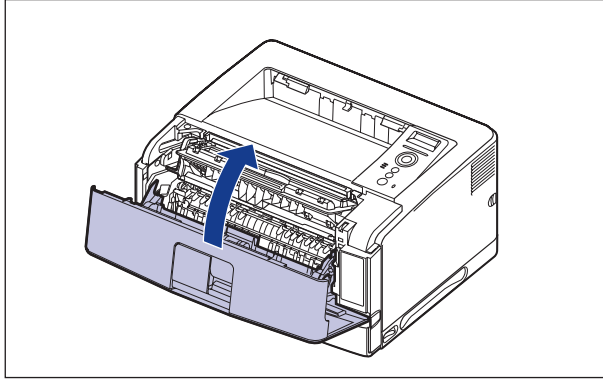

IMPORTANT

- Make sure that the front cover does not open (make sure that there is no space between the front cover and the printer and that the front cover is stable). If the front cover is not closed completely, this may result in poor print quality.
- If you cannot close the front cover, check if the toner cartridge is installed properly. If you try to close the front cover forcefully, this may result in damage to the printer.
- Do not leave the front cover open for a long time after installing the toner cartridge.

Canceling a Job

If you want to cancel the job currently being printed, perform [Cancel Job] using the following procedure. A job cancel allows you to cancel the job currently being received or processed. This option does not affect the next print data or the jobs that have not been processed yet.

IMPORTANT

- Cancel the job while the printer is processing the data (While the ジョブ indicator is on or blinking). No job is canceled by pressing [ジョブキャンセル] when the ジョブ indicator is off.
- The data that has already been processed and is being printed (started to be fed) cannot be canceled. In this case, the next print data may be canceled.
- When there is any print data sent from a printer driver other than that for this printer, multiple data may be canceled.

NOTE

When canceling a job, you may not be able to cancel the job even if <03 ジョブ キャンセル> is displayed.

Cancel a job using the following procedure. When canceling a job, be sure that the ジョブ indicator is on or blinking (when the job that you want to cancel is being received or being processed).



1 Press [ジョブキャンセル].



2 When canceling the job, press [OK].



<03 ジョブ キャンセル> appears, and the print data being processed is canceled. The job is canceled when <00 インサツ カノウ> appears.

IMPORTANT

You cannot operate the printer while <03 ジョブ キャンセル> is displayed.

Confirming the Printer Features

This printer is provided with a function of Status Print that allows you to check the menu settings, etc. Use these functions when required after installing and connecting the printer, for example when you want to check the operation.

Status Print prints information about the currently available functions, a list of the menu settings, and others. Perform Status Print using the following procedure.

NOTE

- Status Print is to be printed on A4 size paper. Load A4 size paper in the paper cassette or multi-purpose tray.
- The settings specified using the menu of the printer's control panel are reflected to Status Print. For example, when the automatic 2-sided printing function is specified, Status Print will be printed with two pages on both sides of paper. However, always a sheet of paper is printed regardless of the number of copies.



1 Make sure that the printer is online.

If the printer is not online, press [オンライン].



2 Press [ユーティリティ].



< ステータスプリント > is displayed in the display.



3 Press [OK].

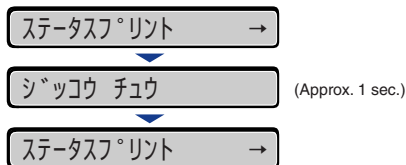

Status Print is printed.

4 Confirm the contents of the Status Print.

Status Print prints information as shown in the following figure. Status Print allows you to confirm information about the currently available functions, a list of the setting values specified in the printer function menu, the versions of the software and hardware equipped with the printer, and number of the total print pages. You can check the number of total print pages using "Page Count" on the lower right of Status Print.



IMPORTANT

This is a sample of Status Print. The contents may differ from the Status Print printed by your printer.

Canon
ステータスプリント
LBP3970

<p>バージョン: XXXXX サブバージョン: XXXXX エンジンバージョン: XXXXX オプションカセットバージョン: XXXXX フォントバージョン: XXXXX</p> <p>拡張機能グループ スリープモード: パネルオフ エクスリース: する スリープモード移行時間: 15分 警告処理トナー交換予告: 継続 待機エネルギーオフ: しない パネル表示言語: 日本語 タッチ: 101 警告表示トナー交換予告: する カセット用紙なし: する ウェイクアップタイマー: 設定しない ウェイクアップ時刻: 12:00 スリープタイマー: 使わない スリープ時刻: 12:00 デュープスリープタイマー: 使わない デュープスリープ時刻: 12:00</p>	<p>給紙グループ デフォルト用紙サイズ: A4 手差しトレイ用紙サイズ: A4 手差しトレイ幅: しない 用紙一枚送り: 使わない 自動選纸手差しトレイ: 使う カセット1: 使う カセット2: 使う カセット3: 使う 用紙名称/手差しトレイ: カセット1: カセット2: カセット3: デフォルト用紙タイプ: 普通紙</p>	<p>レイアウトグループ コピー枚数: 1枚 縦向き幅: 0.0 mm 横向き幅: 0.0 mm とじ方向: 両端とじ とじしろ: 0.0 mm</p> <p>印字調整グループ スーパーズーム: 使う 解像度: 標準 ドラフトモード: 使わない トナー濃度: 1.4 中間選紙システム: 高解像度 グラフィックス: 標準 イメージ: 色調 両頁警告: 継続</p>
<p>インタフェースグループ MP選紙USI: 使う NUP: 使う タイムアウト: 15秒 コネクション認識: する</p>	<p>動作モードグループ 動作モード選択: 自動選択 自動切戻LIPS: 使う ESC/P: 使う 最先エミュレーション: なし</p>	<p>ユーザメンテナンスグループ トレイ幅位置補正: 0.0 mm トレイ幅位置補正: 0.0 mm カセット1幅位置補正: 0.0 mm カセット2幅位置補正: 0.0 mm カセット3幅位置補正: 0.0 mm カセット4幅位置補正: 0.0 mm カセット5幅位置補正: 0.0 mm カセット幅位置補正: 0.0 mm リカバリ処理: する 特殊モード1: 使わない 前継ぎ文字認識: しない うねり特殊処理: しない 画像特殊処理: モード1</p>

デバイス	製造会社: XXXXX 製品名: XXXXX 表示名: XXXXX シリアルナンバー: XXXXX	
搭載コントローラ	LIPS: XXXXX LIPS EX: XXXXX ESC/P: XXXXX	LIPSは、キヤノン株式会社の商標です。 ESC/Pは、セイコーエプソン株式会社の商標です。
標準ネットワーク	バージョン: XXXXX MAC Address: XXXXX	
USB	ペンダーID: XXXXX プロダクトID: XXXXX シリアルナンバー: XXXXX USB動作モード: XXXXX	

CanonおよびCanonロゴはキヤノン株式会社の商標です。

2006/10/16 19:07:36

Page Count : 0000008

Service Call Display

When a problem has occurred and the printer does not work properly, the service call shown in the figure appears:

Message	Cause	Remedy
<div style="border: 1px solid gray; padding: 2px; display: inline-block;">E_{nnn}-_{nnnn}</div> ("n" represents an alphanumeric character)	A problem has occurred inside the printer.	Cycle the power of the printer using the following procedure. If the message does not disappear after cycling the power of the printer several times, contact your local authorized Canon dealer.
<div style="border: 1px solid gray; padding: 2px; display: inline-block;">E001-_{nnnn}</div> <div style="border: 1px solid gray; padding: 2px; display: inline-block;">E003-_{nnnn}</div> ("n" represents an alphanumeric character)	A problem has occurred with the fixing unit of the printer.	Perform the following procedures from the Step 2 to contact your local authorized Canon dealer.
<div style="border: 1px solid gray; padding: 2px; display: inline-block;">F9-_{nn} <small>フィックスユニット</small></div> ("n" represents an alphanumeric character)	A problem has occurred while the printer is processing print data.	Cycle the power of the printer using the following procedure.

- 1 Turn the power OFF, wait for 10 seconds or longer, and then turn it ON again.**

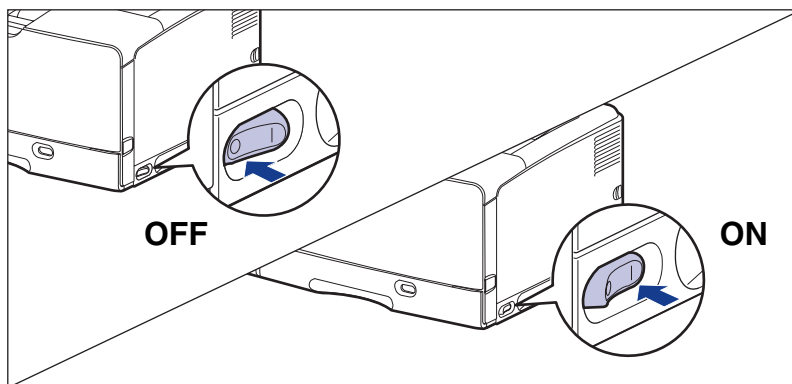

If the message does not reappear, the printer can be used as normal. If the error message still appears, proceed to the next step.

2 Note down the alphanumeric characters and message in the display.

3 Perform the following procedure.

Turn the printer OFF ①.

If a USB cable is connected, turn the computer off ②, and then disconnect the USB cable ③.

Disconnect the power plug from the AC power outlet ④.

Remove the ground wire from the ground terminal ⑤.

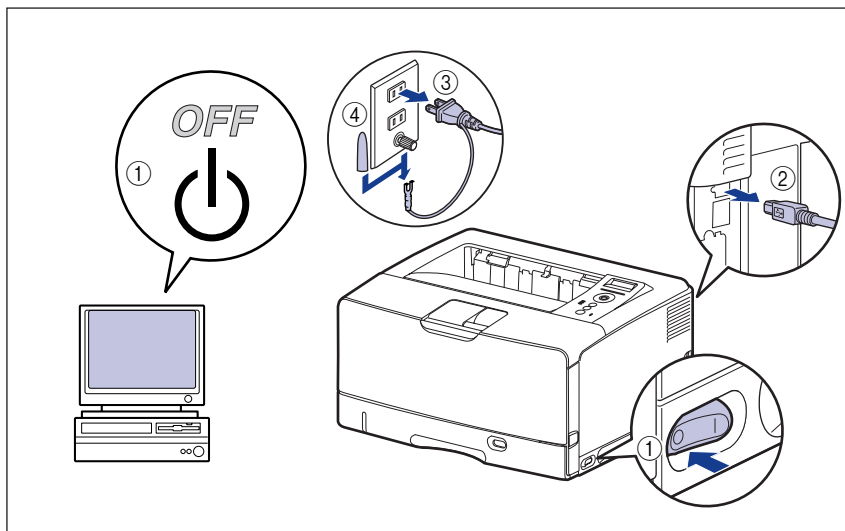

IMPORTANT

After removing the power cord, store the ground wire with its cap on.

4 Contact your local authorized Canon dealer.

When contacting your Canon dealer, please report the problems and the code number that you have noted.

Message List

When the printer cannot continue printing for some reason (an error status), the printer beeps, the メッセージ indicator comes on, and an error message that indicates the description of the error appears in the display. A Warning message appears in the display when the printer requires some remedy (a warning status) although the job is not affected.

If either of these messages appears, perform the following procedures according to the message.

NOTE

- When multiple warnings are occurring at the same time, the Warning messages appear by rotation.
- When the printer is in error status and warning status at the same time, the Warning message does not appear.
- For a message with the <Warning Message> mark, the printer does not stop the operation even when the message is being displayed (when the printer is in a warning status).
- <For a message with the <Auto Error Skip> mark, you can skip the error by pressing [オンライン] and continue printing. However, part of the print data may be missing or it may not be printed properly. When you want to stop the process, perform a soft reset to eliminate the cause of the error, press [オンライン], and then print again. Also, you can automatically skip the errors to which this mark is attached by setting <ジドウ エラースキップ> in the セットアップ menu to <スル>.

Message	Cause and Remedy
02 レイキヤクチュウ	<p>Cause The temperature of the fixing unit exceeded a fixed value after printing (especially paper with a narrower width) continuously.</p> <p>Remedy Please wait a moment. The printer cools down the fixing unit automatically. It resumes the job after finishing the cool down process.</p>
11 XXX ヨウシガアリマセン (xxx indicates abbreviations of paper sizes)	<p>Cause Paper of the size specified in the application is not loaded in the paper source (in all the paper sources when <キューシモード> is set to <ジドウ>; in the specified paper source when the setting is fixed).</p> <p>Remedy Refill or load paper.</p>

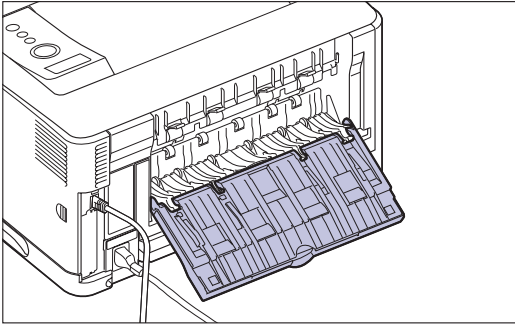
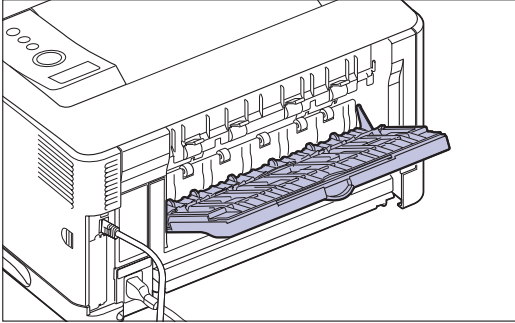
Message	Cause and Remedy
<p>12 カバーが アイティマス</p>	<p>Cause The front cover is open, or the sub-output tray is open to the position shown in the figure.</p>  <p>Remedy Close the front cover firmly or close the sub-output tray to the position shown in the figure. If the printer is not online, press [オンライン].</p> 
<p>13 ヨウシガ ツマリマシタ</p>	<p>Cause Paper is jammed inside the printer.</p> <p>Remedy Remove the jammed paper and set the paper cassette and covers to the original position. If the printer is not online, press [オンライン].</p>
<p>14 トナー ミソウチャク</p>	<p>Cause The toner cartridge is not installed or installed improperly.</p> <p>Remedy Install the toner cartridge properly.</p>
<p>16 トナー ヨウイ <Warning Message></p>	<p>Cause A toner cartridge needs to be replaced soon.</p> <p>Remedy Although you can continue to print for a while, have ready a new toner cartridge. When you print a large amount of data, or white patches appear on the images, replace the toner cartridge with a new one. If the printer is not online after closing the front cover, press [オンライン].</p>

Message	Cause and Remedy
16 トナー カクニン	<p>Cause A toner cartridge needs to be replaced soon.</p> <p>Remedy Press [オンライン]. Although you can continue to print for a while, have ready a new toner cartridge. When you print a large amount of data, or white patches appear on the images, replace the toner cartridge with a new one. If the printer is not online after closing the front cover, press [オンライン].</p>
18 カセット2 ナシ (LBP3970 only)	<p>Cause Cassette 2 is not set.</p> <p>Remedy Set Cassette 2.</p>
18 カセット3 ナシ (LBP3970 only)	<p>Cause Cassette 3 is not set.</p> <p>Remedy Set Cassette 3.</p>
18 カセット2 ヨウシオーバー	<p>Cause The amount of paper loaded in Cassette 2 exceeds the load limitation.</p> <p>Remedy Reduce the amount of paper in Cassette 2.</p>
18 カセット3 ヨウシオーバー (LBP3970 only)	<p>Cause The amount of paper loaded in Cassette 3 exceeds the load limitation.</p> <p>Remedy Reduce the amount of paper in Cassette 3.</p>
18 カセット4 ヨウシオーバー (LBP3970 only)	<p>Cause The amount of paper loaded in Cassette 4 exceeds the load limitation.</p> <p>Remedy Reduce the amount of paper in Cassette 4.</p>
18 キュウシ エラー	<p>Cause Paper of the size or type that cannot be fed from the multi-purpose tray or paper cassettes is specified.</p> <p>Remedy If a paper source is specified, press [給紙選択], then set <キュウシモード> to <ジドウ>.</p>
1F ハイシトレイ フル	<p>Cause The output tray is full.</p> <p>Remedy Remove the paper in the output tray.</p>
1G トナー カクニン <Warning Message>	<p>Cause The toner cartridge has reached the end of its life.</p> <p>Remedy Take the toner cartridge out of the printer and replace it with a new one.</p>
1H トナーセツゾクカクニン <Warning Message>	<p>Cause There is a possibility that the toner cartridge is not installed properly.</p> <p>Remedy Remove the toner cartridge and reinstall it properly.</p>
32 リョウメンインサツ エラー <Auto Error Skip>	<p>Cause The printer received data for 2-sided printing of a paper size (including the paper orientation) or paper type on which the printer cannot perform automatic 2-sided printing.</p> <p>Remedy Press [オンライン] to continue printing. However, the data on each side is printed on two pages.</p>

Message	Cause and Remedy
<p>41 ヨウシサイズ カクニン <Auto Error Skip></p>	<p>Cause The size of the paper loaded in the multi-purpose tray is different from the setting for <テザシトレイ ヨウシサイズ> specified from the computer or control panel.</p> <p>Remedy Match the size specified in <テザシトレイ ヨウシサイズ> and the size of the loaded paper, and then press [オンライン].</p> <p>Cause You are using LIPS LX Printer Driver, and you loaded custom size paper of its long edges 312.0 mm (297.0 mm for a paper cassette) or less and printed.</p> <p>Remedy Load the paper in landscape orientation, then print again.</p>
<p>96 サブハイシトレイカクニン /シメテ クダサイ</p>	<p>Cause Paper was to be output with the printed side facing up during automatic 2-sided printing.</p> <p>Remedy Close the sub-output tray. The printer resumes printing, and the paper is output to the output tray.</p>
<p>9F トナーカクニン <Warning Message></p>	<p>Cause There is a possibility that a used toner cartridge that has reached its lifetime is installed.</p> <p>Remedy Check if the toner cartridge is proper.</p>
<p>PC XXX ヨウシニ コウカン (xxx indicates abbreviations of paper sizes)</p>	<p>Cause The paper of the size specified in the application is not loaded in the paper cassette or multi-purpose tray, or the paper source for the different paper size is selected.</p> <p>Remedy Load the paper of the size selected in the application (or the one specified by scaling factors).</p>